

# M A N U A L

INDUSTRIAL HARDWARE SET FOR OVERHEAD DOOR

PRZEMYSŁOWY ZESTAW MONTAŻOWY DO BRAM SEKCYJNYCH

## ISC-FHL

CE

INSTALLATION / MAINTENANCE

INSTRUKCJA MONTAŻU/KONSERWACJI



## ATTENTION! GENERAL WARNINGS!



To install, use and maintain this door safely, a number of precautions must be taken. For the safety of all concerned pay heed to the warnings and instructions given below! If in doubt, contact your supplier.



**SPECIAL SAFETY WARNINGS OR REMARKS IN THIS MANUAL ARE INDICATED WITH THIS SYMBOL: READ THESE WARNINGS CAREFULLY.**

- ✓ This manual has been written for use by experienced fitters and as such is not suitable for d.i.y. purposes or for use by trainee fitters.
- ✓ This manual describes the installation of the hardware set components, door sections (panels) and refers to installation manuals of the electrical operators. Be sure to supplement this manual if needed with instructions for any additional components not described in this manual.
- ✓ Before starting, read this manual carefully!
- ✓ Certain components may be sharp or have jagged edges. As such you are advised to wear safety gloves.
- ✓ All the components which have been supplied are designed for use with this specific overhead door. Replacement or adding additional components may have an adverse effect on the safety of, and the guarantee on, the door. Also the CE-approval which has been granted to this door combination will be cancelled when components are changed or installation is not done according to this manual! Installer is responsible for this.
- ✓ During tensioning, springs can exert large forces. Work carefully. Use the proper equipment. Ensure that you are standing in a steady position.
- ✓ Ensure that there is sufficient light during installation. Remove obstacles and dirt. Make sure that there is no one else present other than the fitters. Other people (children!) may get in the way or endanger themselves during the installation.
- ✓ Ensure that the building is constructed strong enough to carry the overhead door construction. It is the responsibility of the installing company to use fixing materials which are strong enough and equipped to fix the overhead door to the building.
- ✓ A power operated overhead door may not be equipped with a pull cord (rope). Be sure that this has been removed when a manual operated door is being equipped with an E-operator.
- ✓ Environments closed by an electrical operated overhead door with operators which are not disconnectable and where the door cannot be manual operated must be equipped with a pass door.
- ✓ Cutting of the bottom section is not allowed. The forces on cable break devices and bottom brackets are too high. Cutting is weakening the construction of the door on this critical point.

### **This door can only be taken into use, when all instructions are followed and:**

- ✓ The installer has checked the combination of hardware, panel and e-operator as being approved and safe. Make sure to check the max. peak force and the proper functioning of the safety edge system in combination with the operator.
- ✓ All documentation has been handed over to the end-user: Ila Declaration of conformity, User Guide, Maintenance Instructions, Dismantling instructions, Service Log Book and this manual.
- ✓ A CE-identification plate has been placed on the door.
- ✓ User has been given instructions and demonstration of the proper use and functioning of the door.

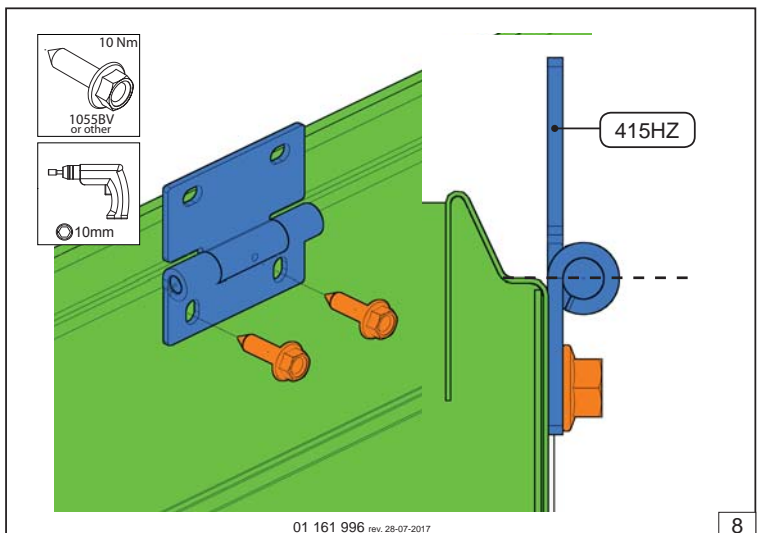
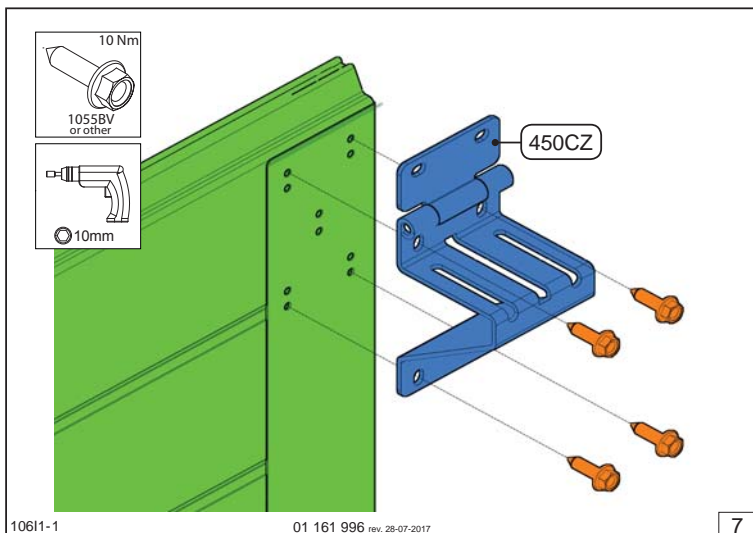
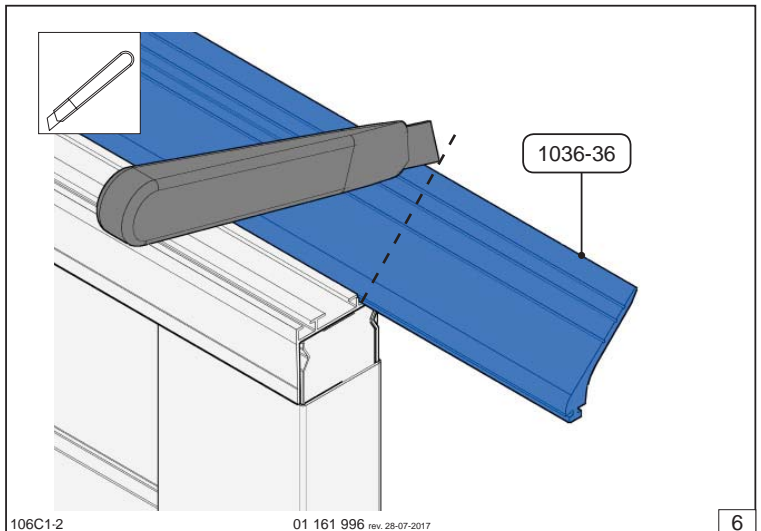
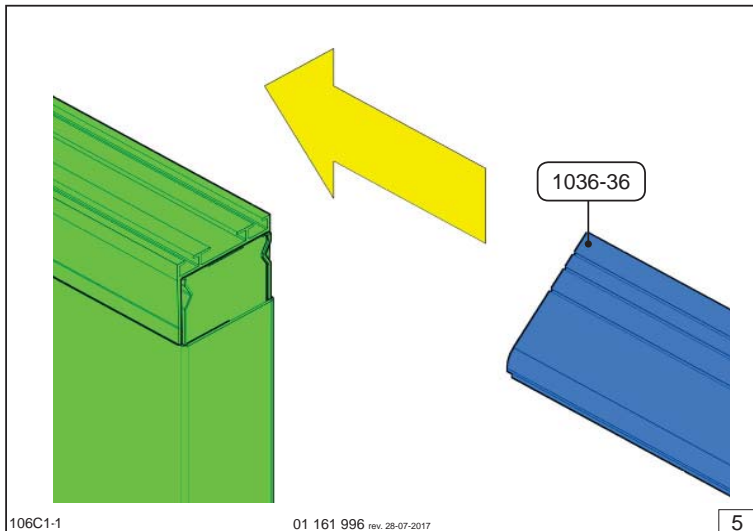
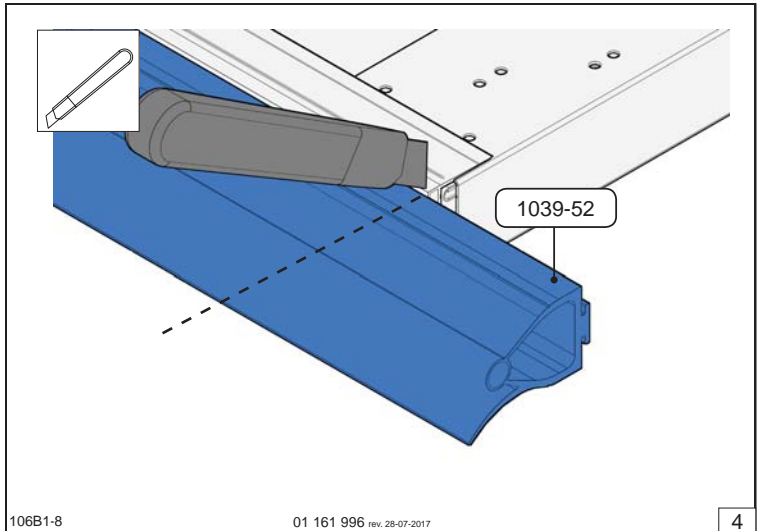
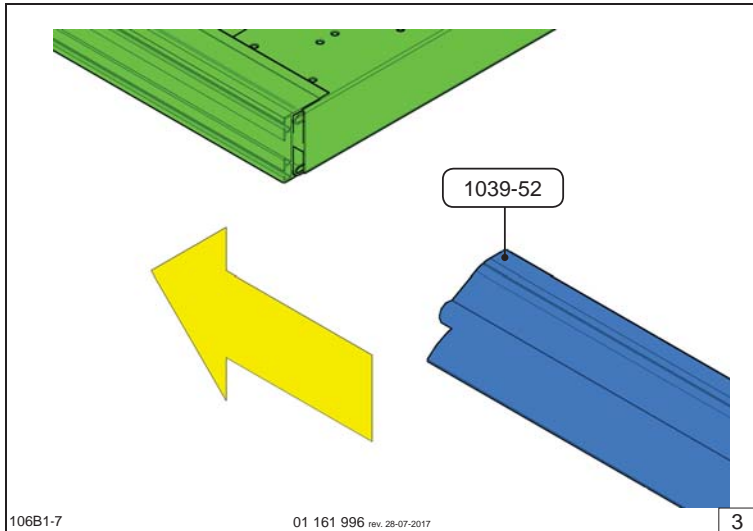
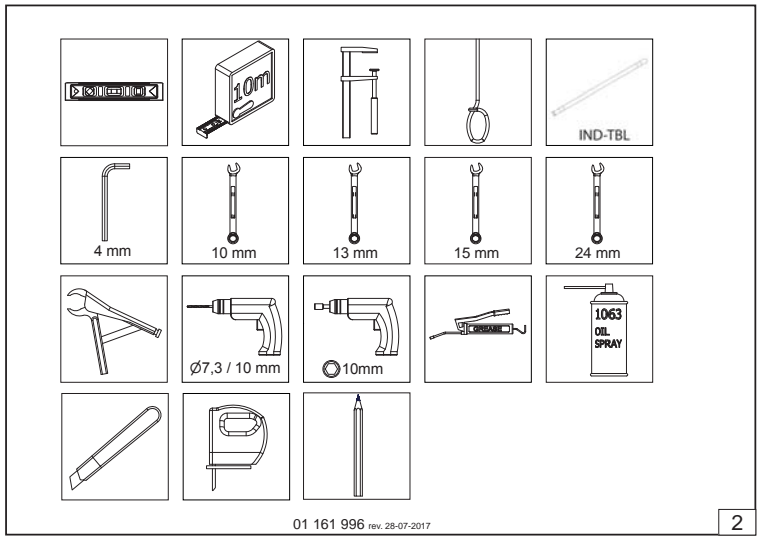
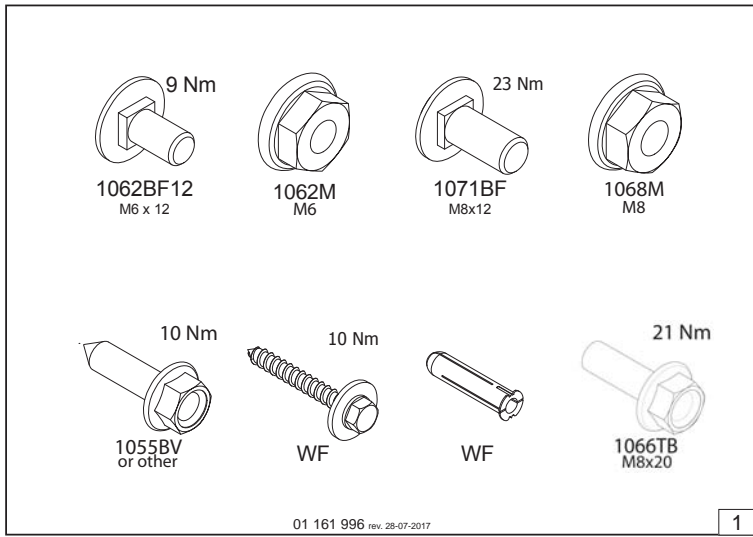

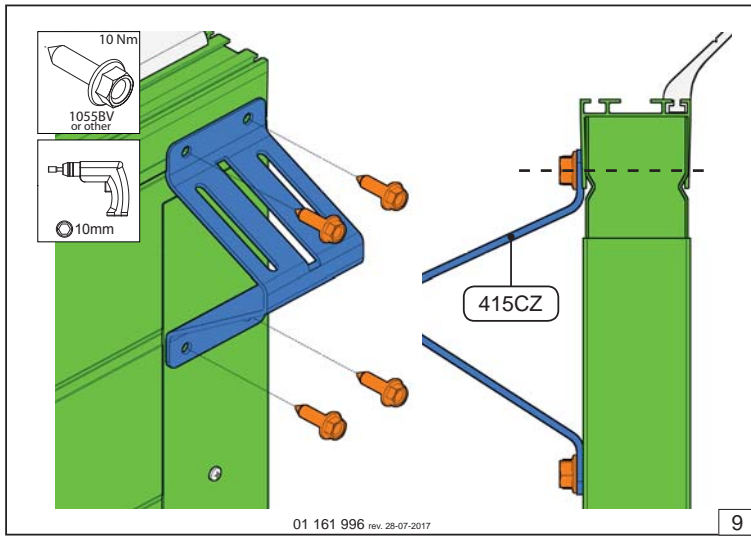

9

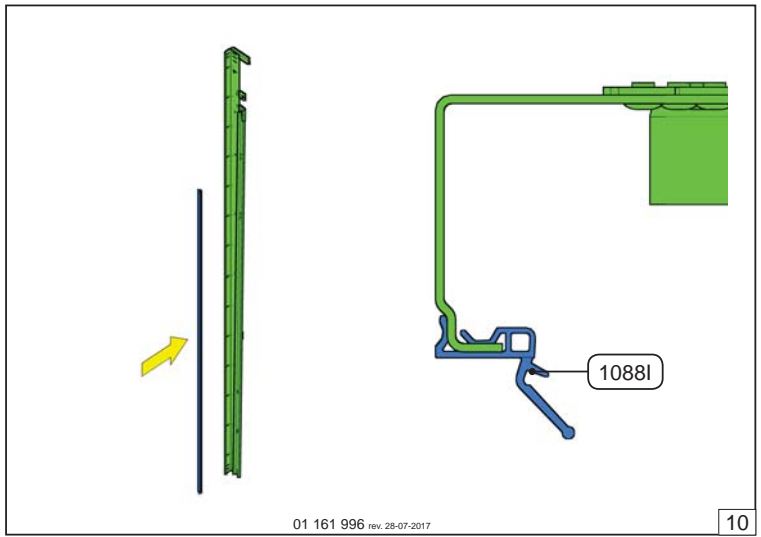

10

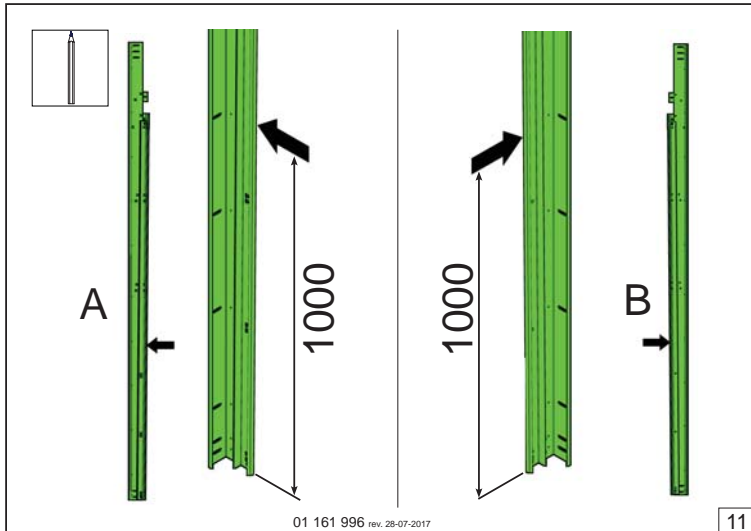

11

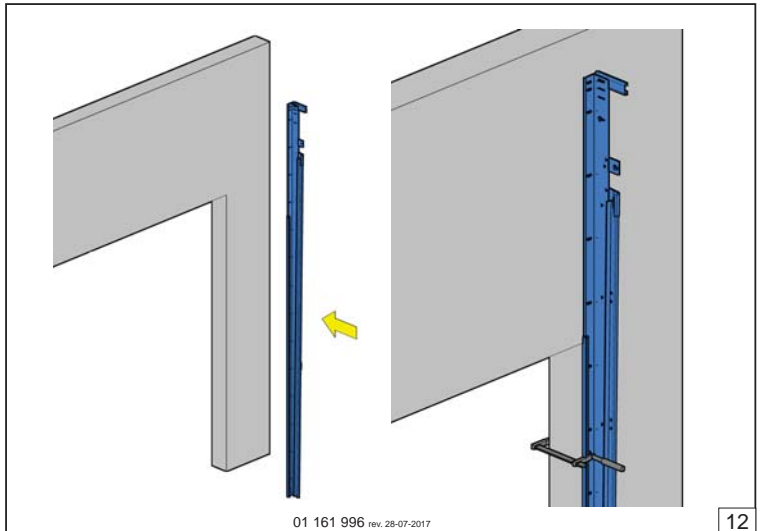

12

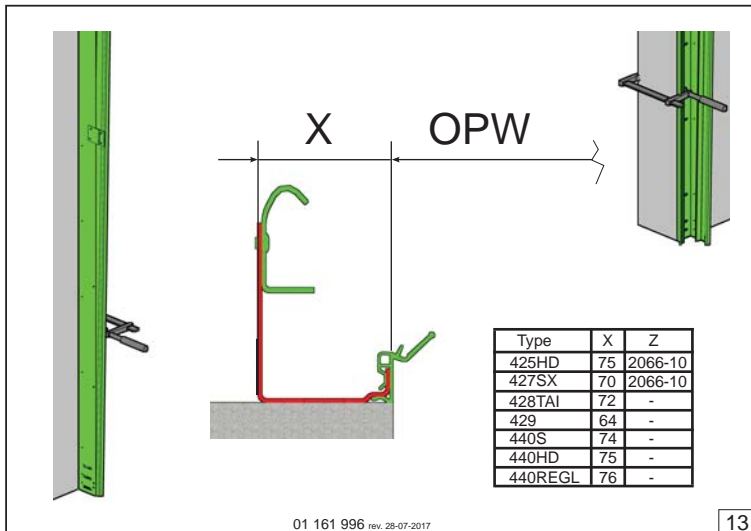

13

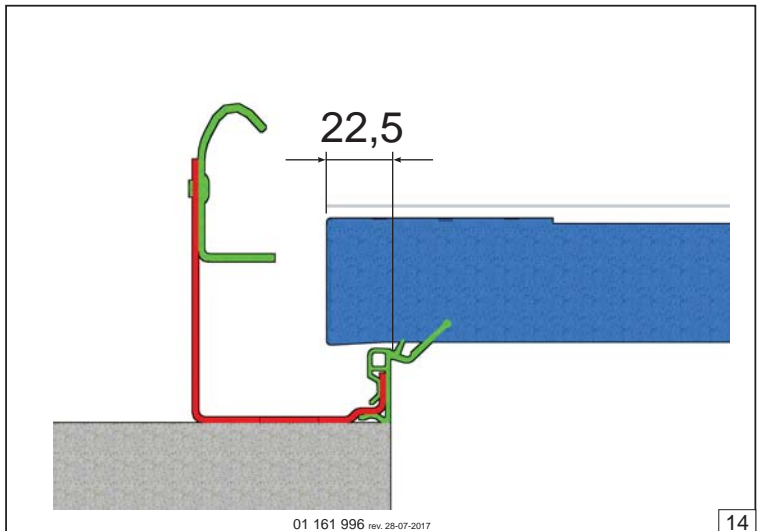

14

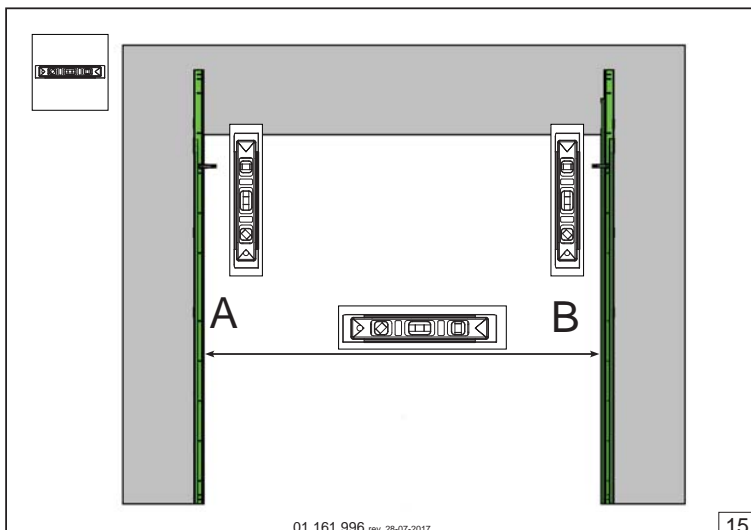

15

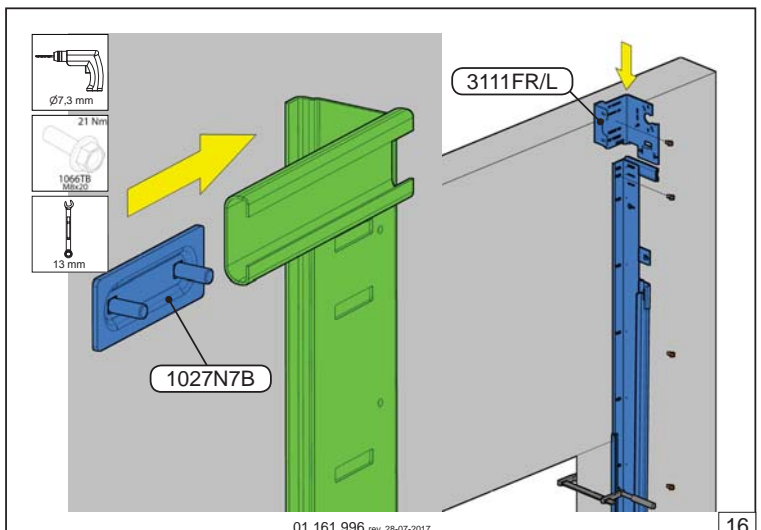

16

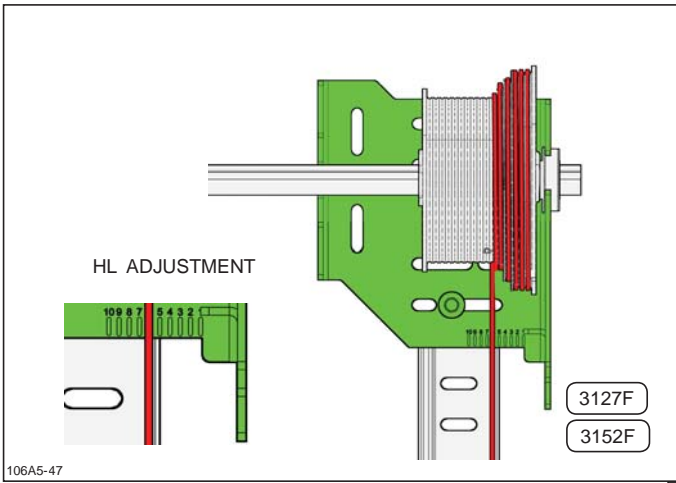

01 161 996 rev. 28-07-2017

17

Cable drum		HL (mm)	1370	1002	634	266						
FFHL54 HL max. 1370 mm	HL (mm)											
	Adjustment indication		1	2	3	4						
FFHL120 HL max. 3010mm	HL (mm)		3010	2520	2031	1541	1052	562	72			
	Adjustment indication		1	2	3	4	5	6	7			
FFHL164 HL max. 4100 mm	HL (mm)		4100	2673	3246	2819	2392	1965	1538	1110	683	256
	Adjustment indication		1	2	3	4	5	6	7	8	9	10

01 161 996 rev. 28-07-2017

18

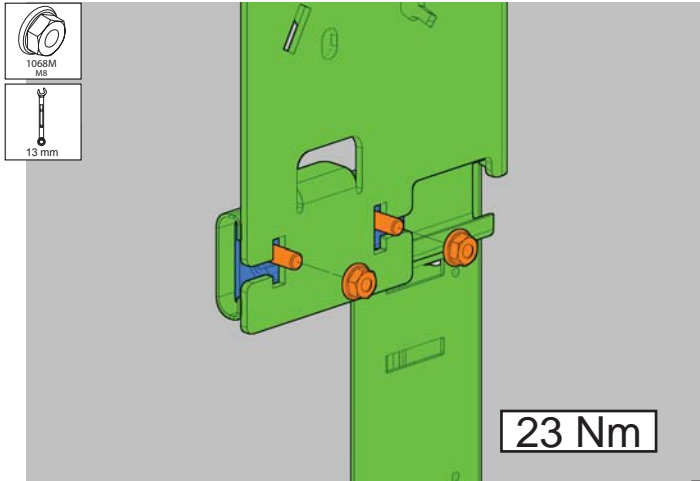

01 161 996 rev. 28-07-2017

19

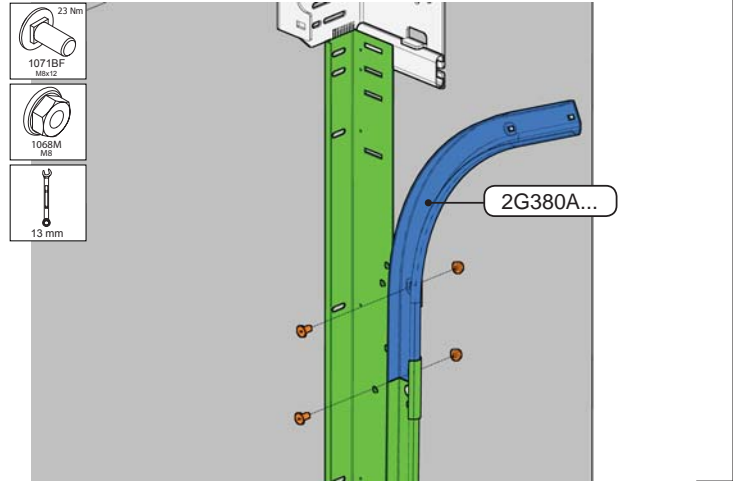

01 161 996 rev. 28-07-2017

20

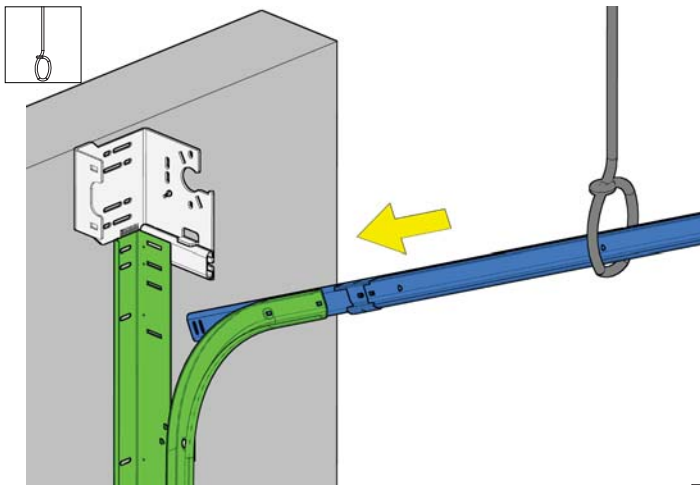

01 161 996 rev. 28-07-2017

21

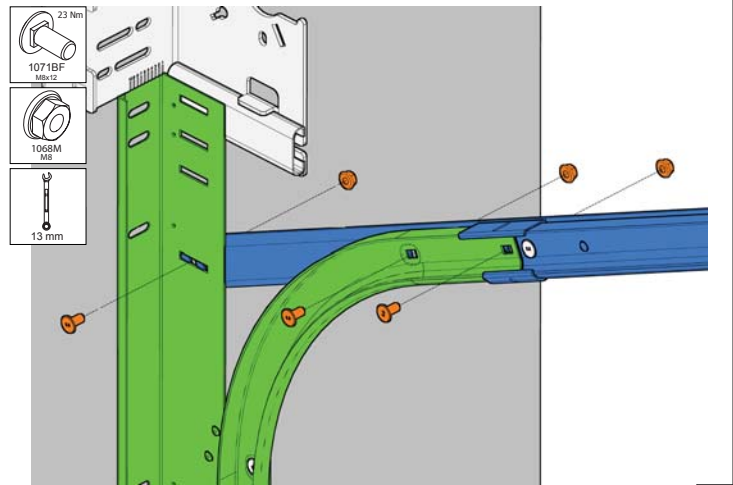

01 161 996 rev. 28-07-2017

22

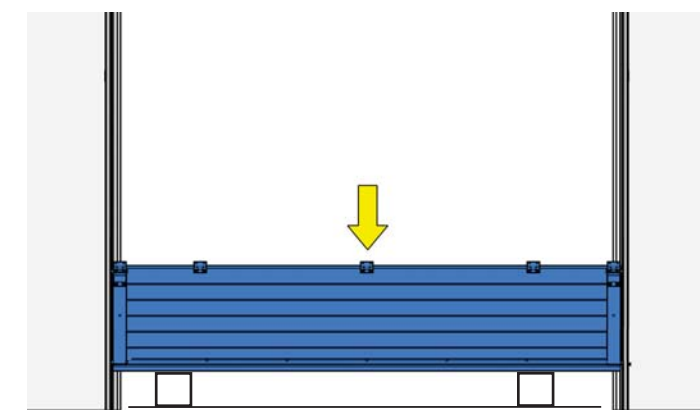

01 161 996 rev. 28-07-2017

23

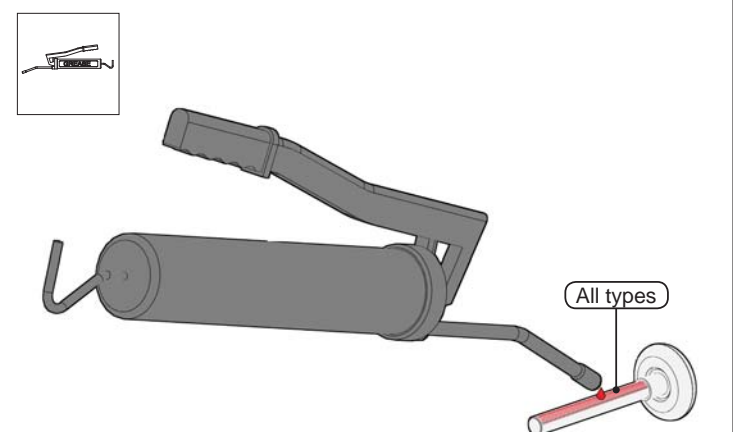

106A-17

01 161 996 rev. 28-07-2017

24

106A-18

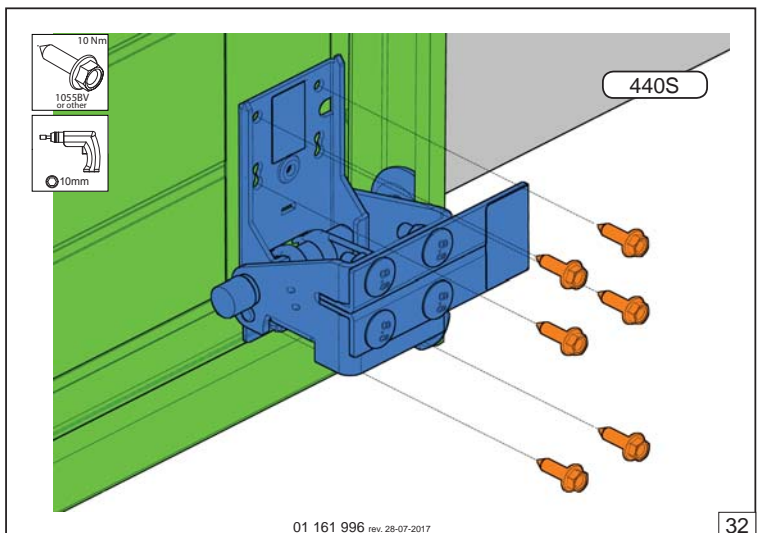
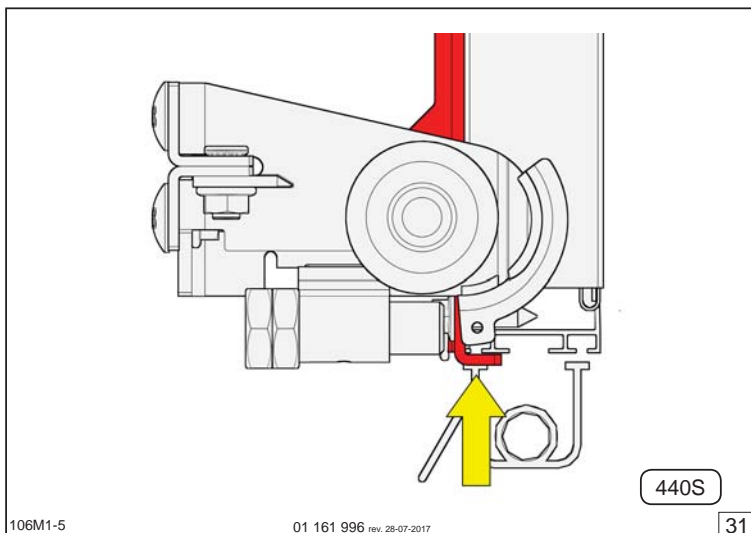
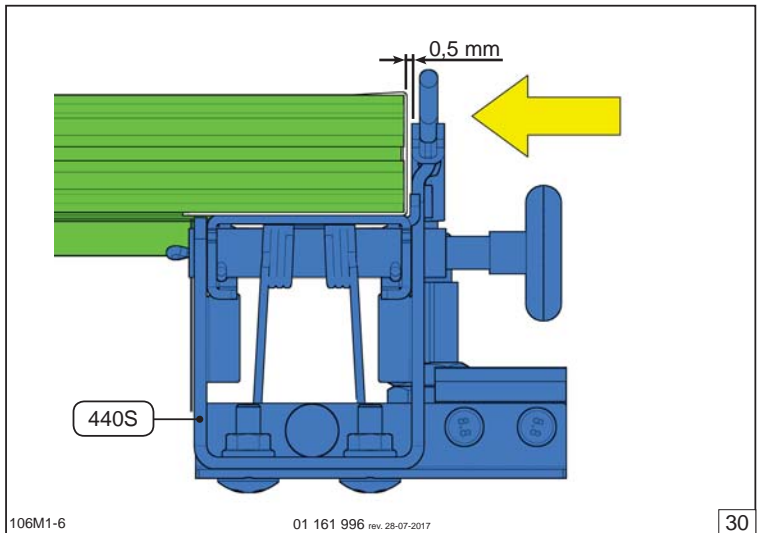
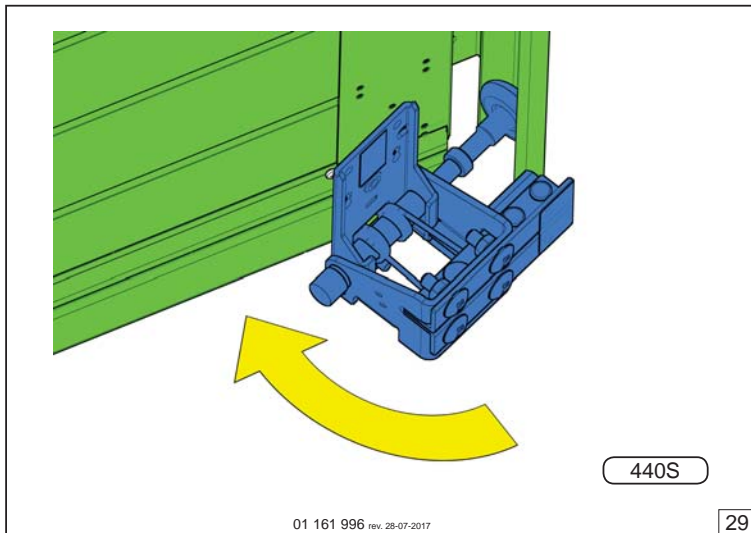
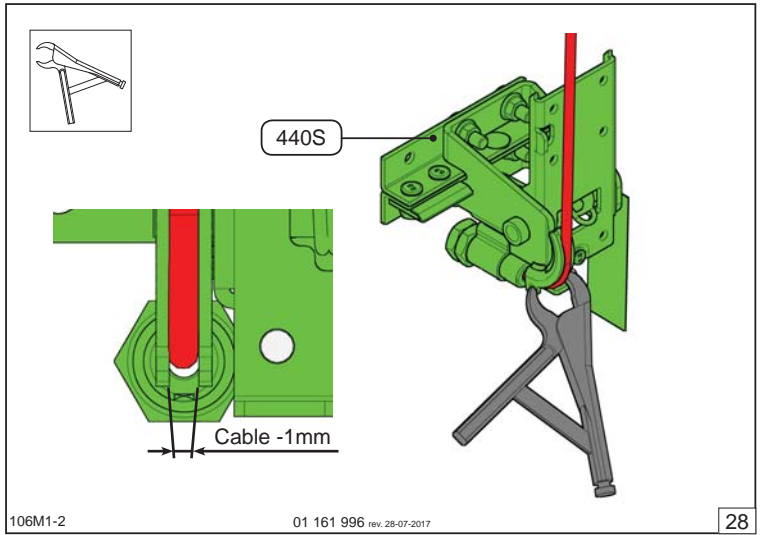
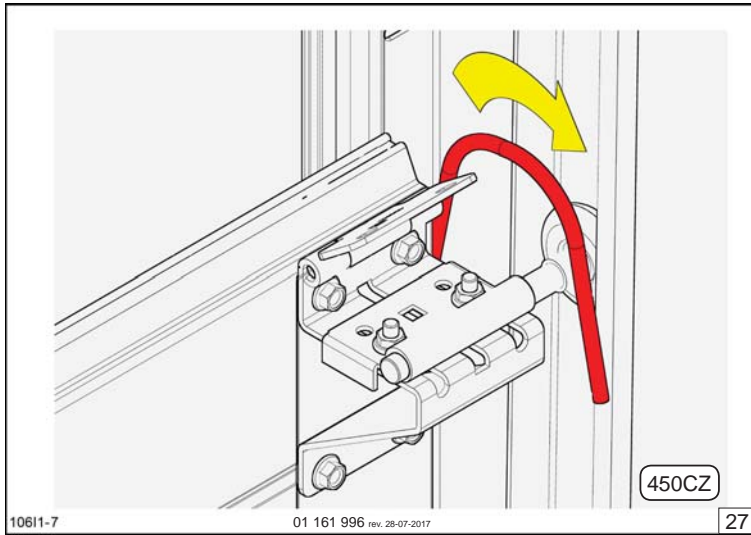
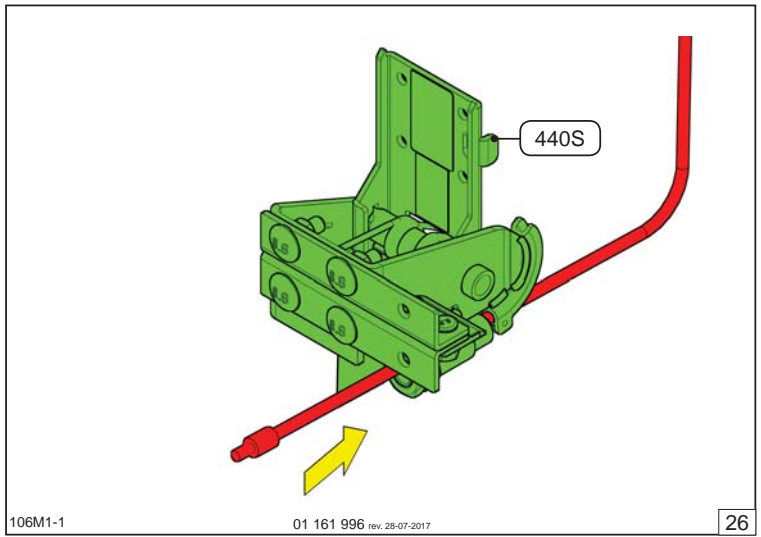
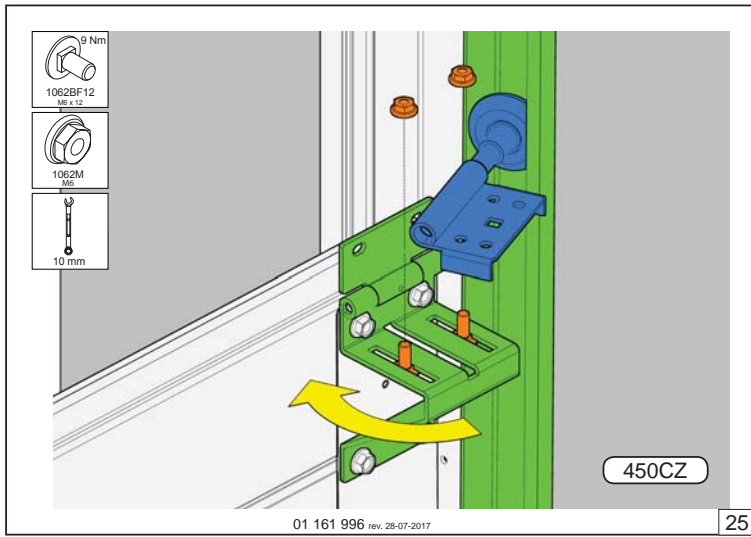

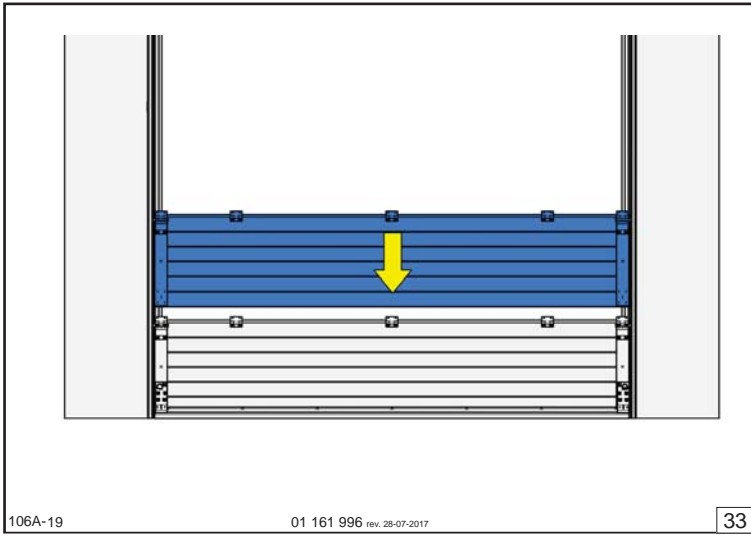

106A-19

01 161 996 rev. 28-07-2017

33

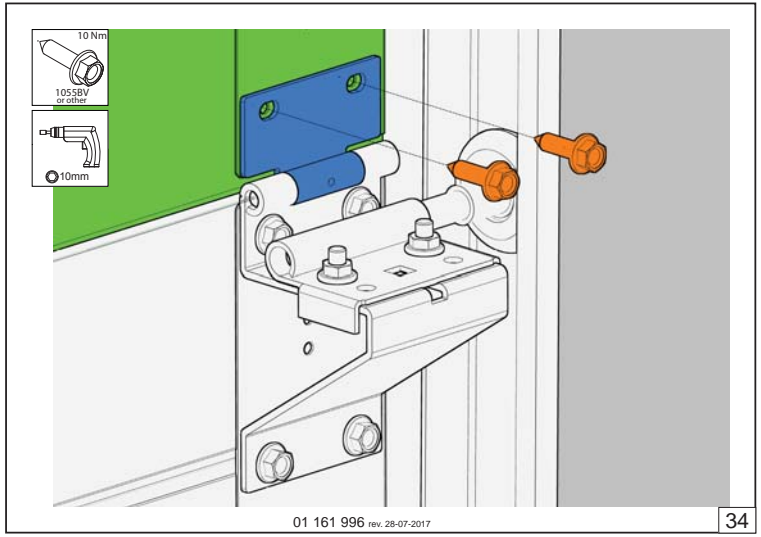

01 161 996 rev. 28-07-2017

34

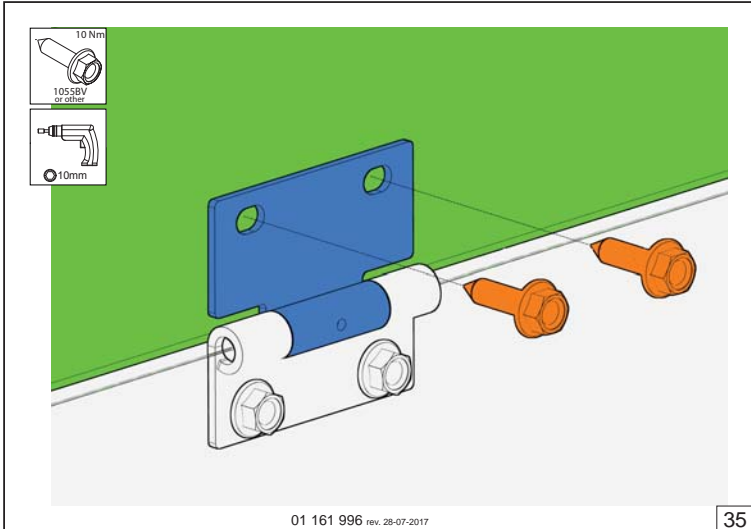

01 161 996 rev. 28-07-2017

35

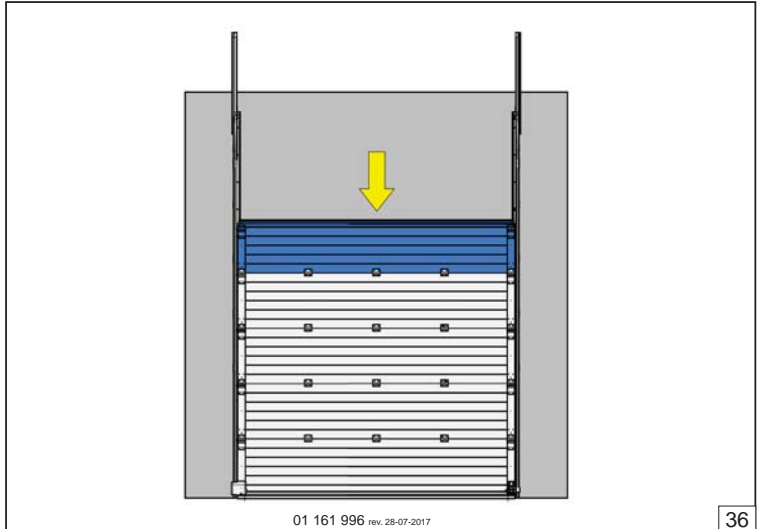

01 161 996 rev. 28-07-2017

36

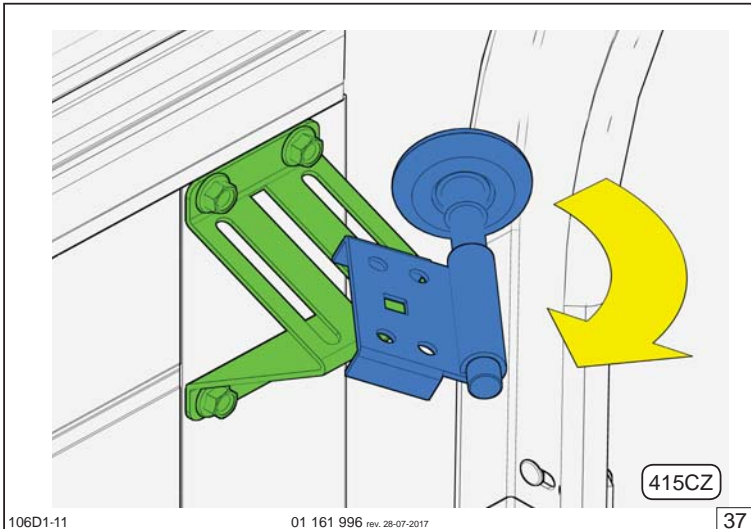

106D1-11

01 161 996 rev. 28-07-2017

37

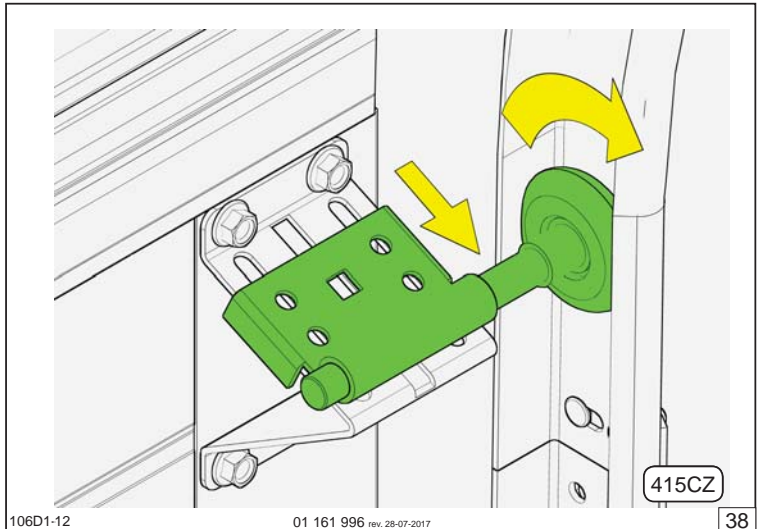

106D1-12

01 161 996 rev. 28-07-2017

38

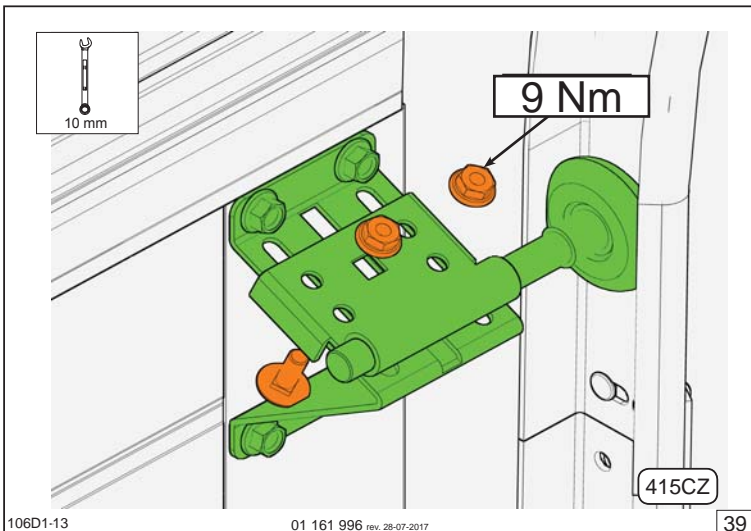

106D1-13

01 161 996 rev. 28-07-2017

39

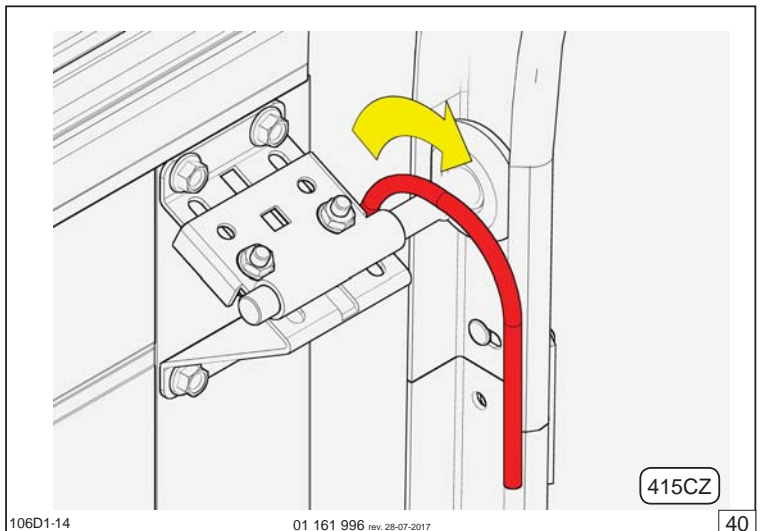

106D1-14

01 161 996 rev. 28-07-2017

40

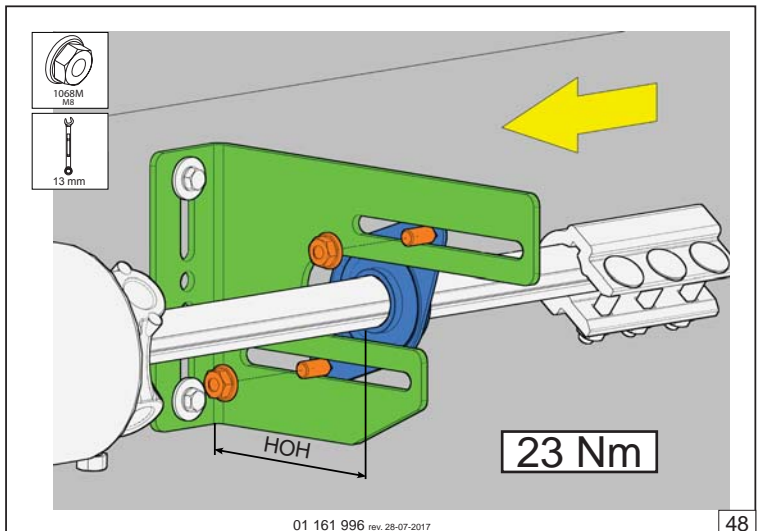
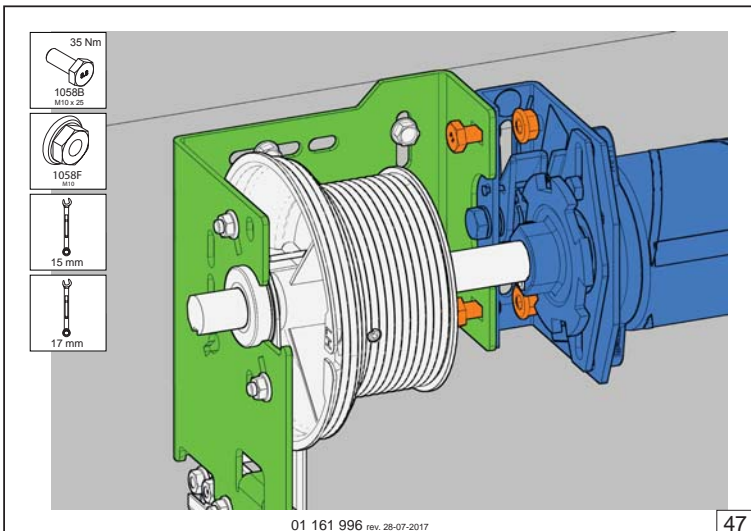
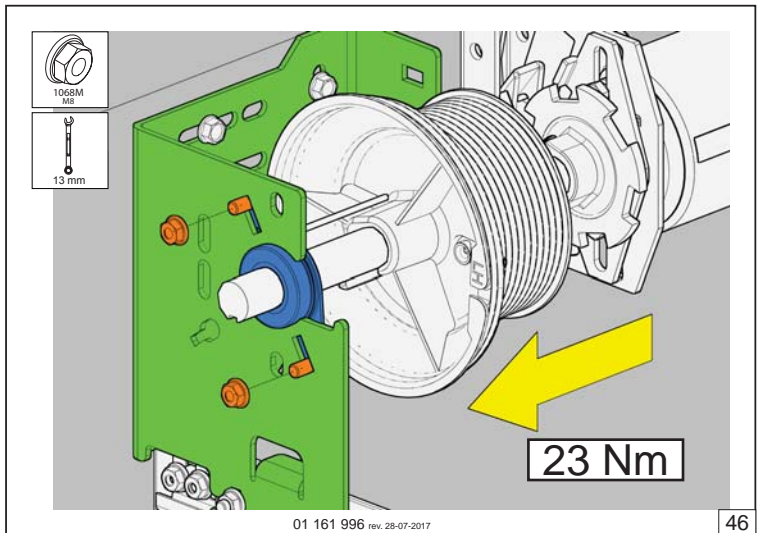
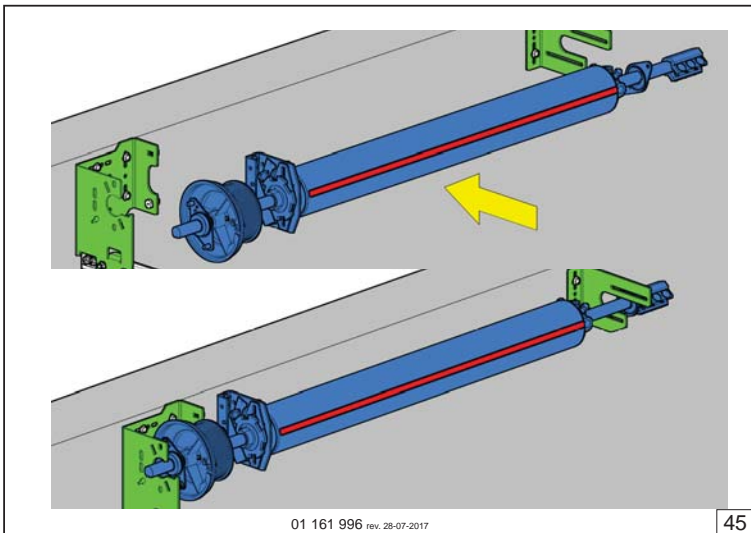
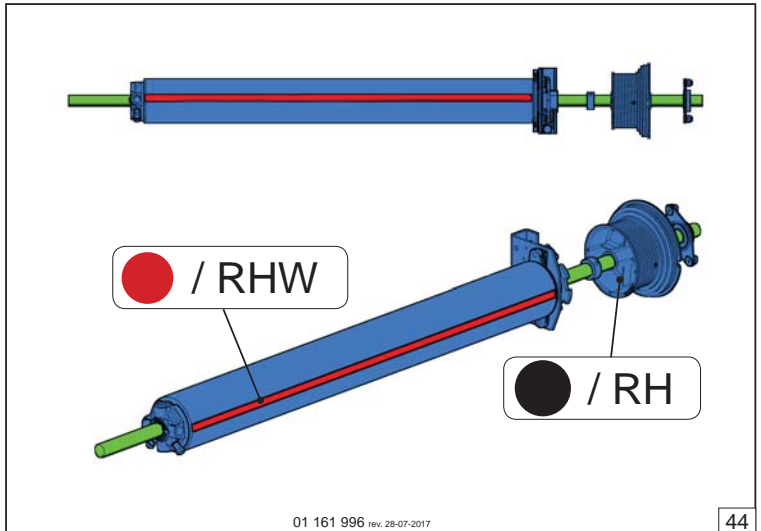
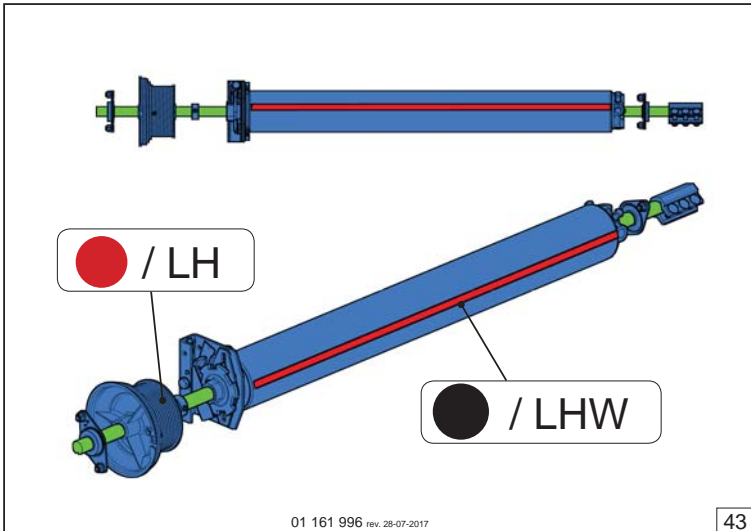
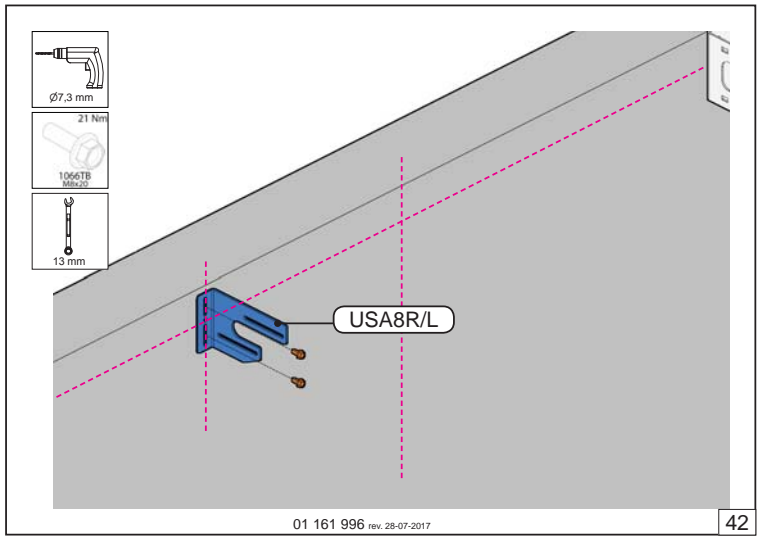
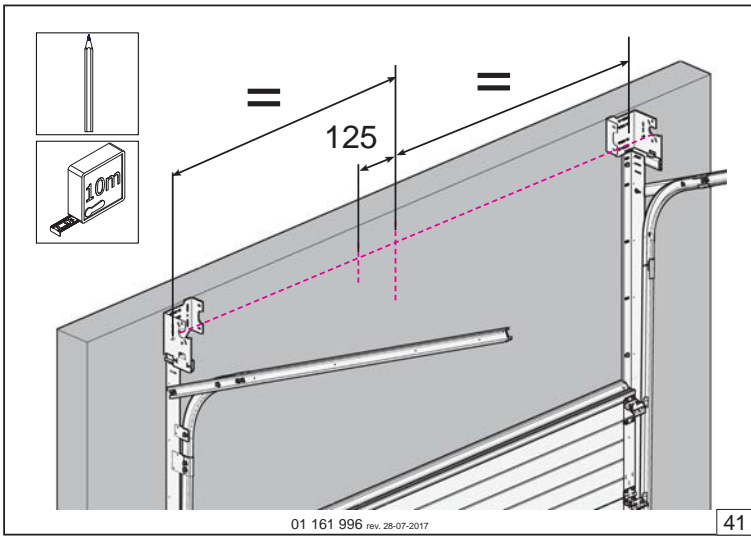



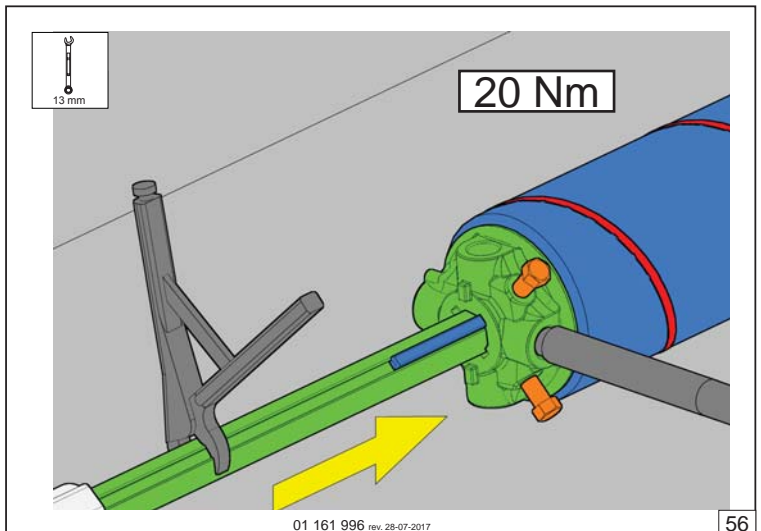
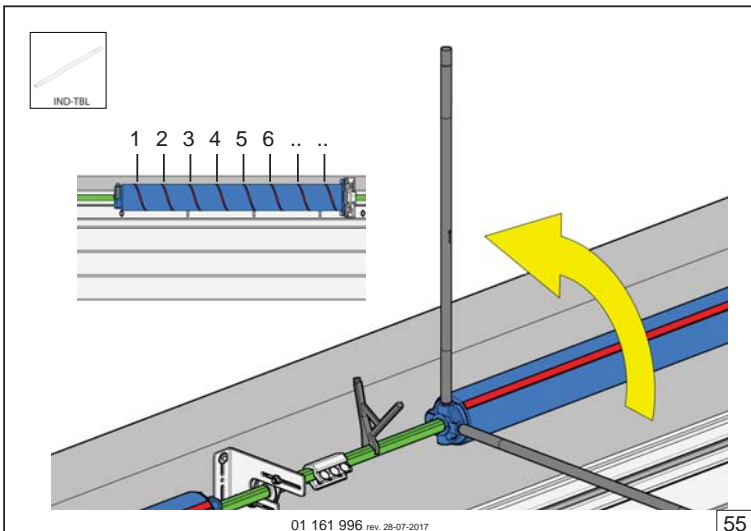
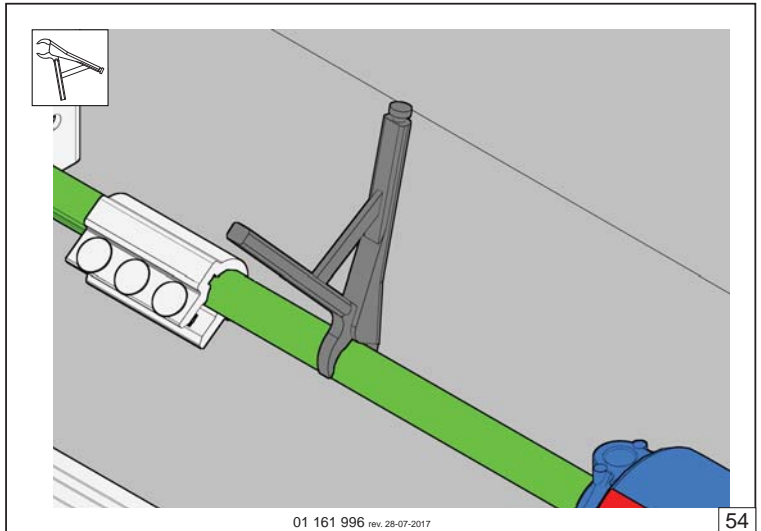
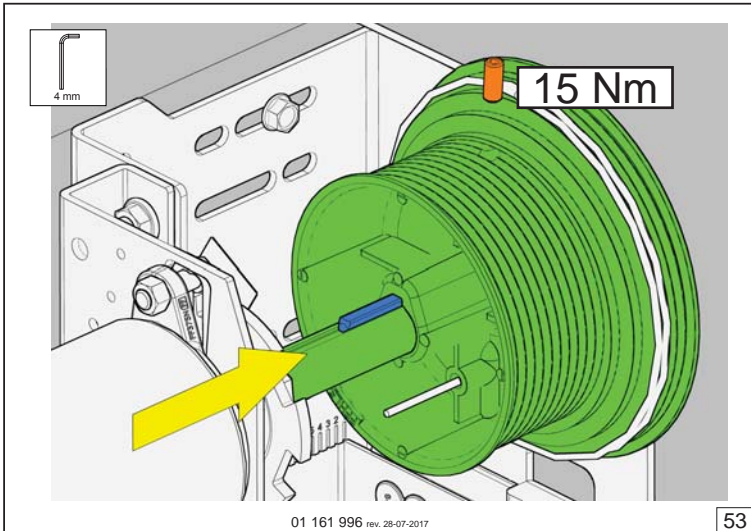
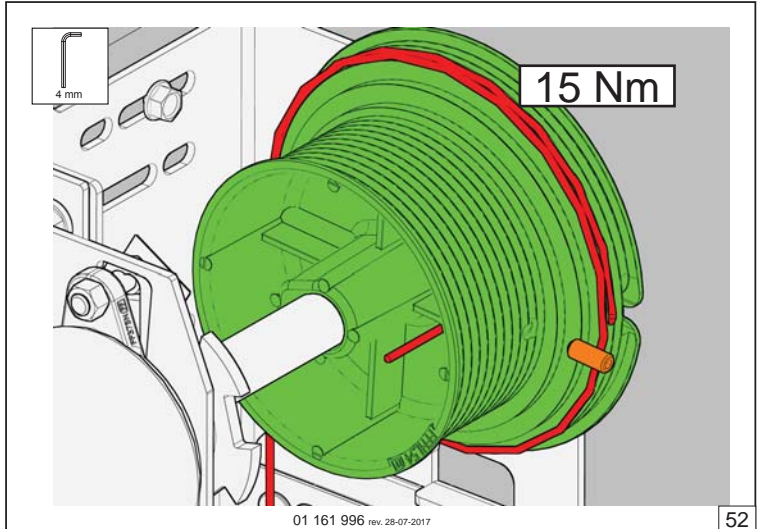
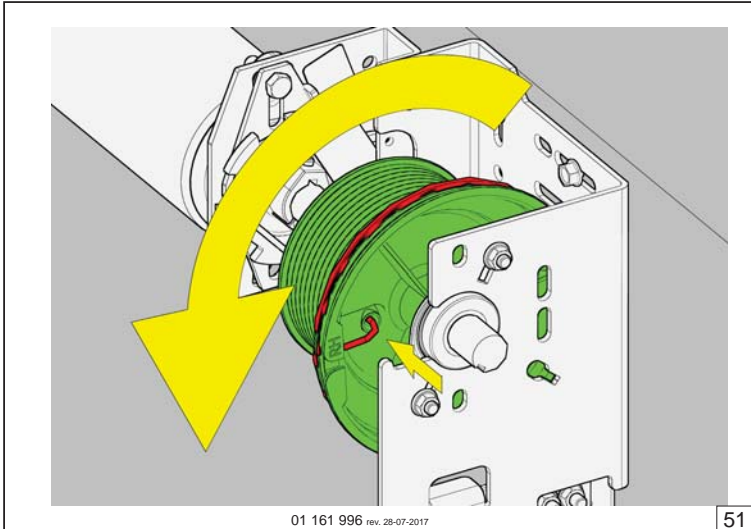
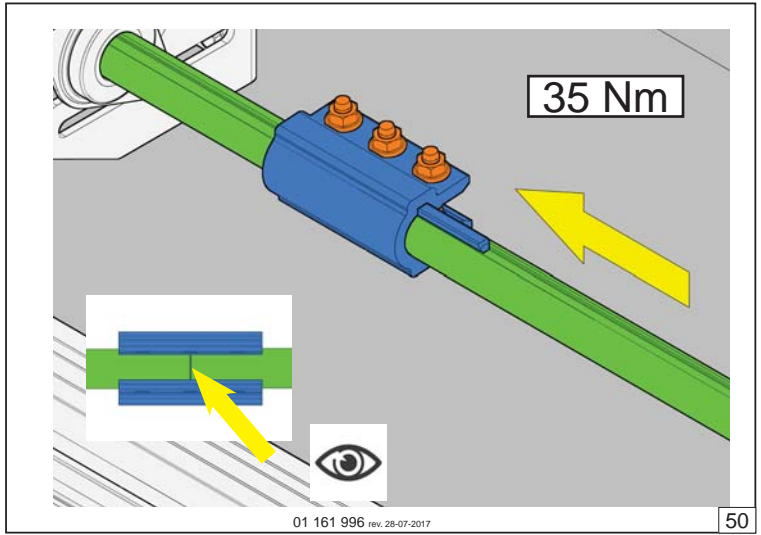
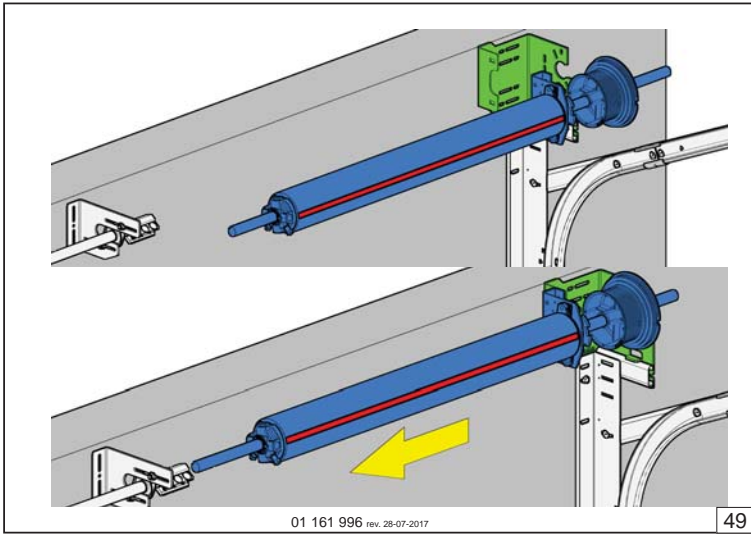

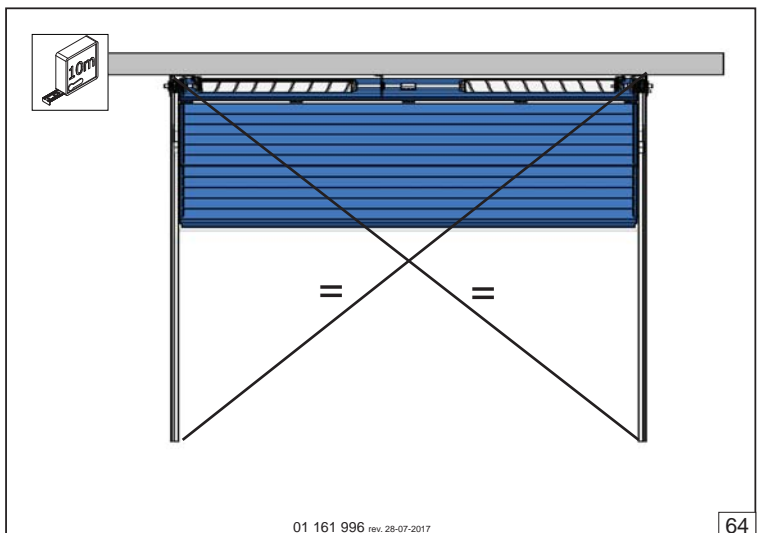
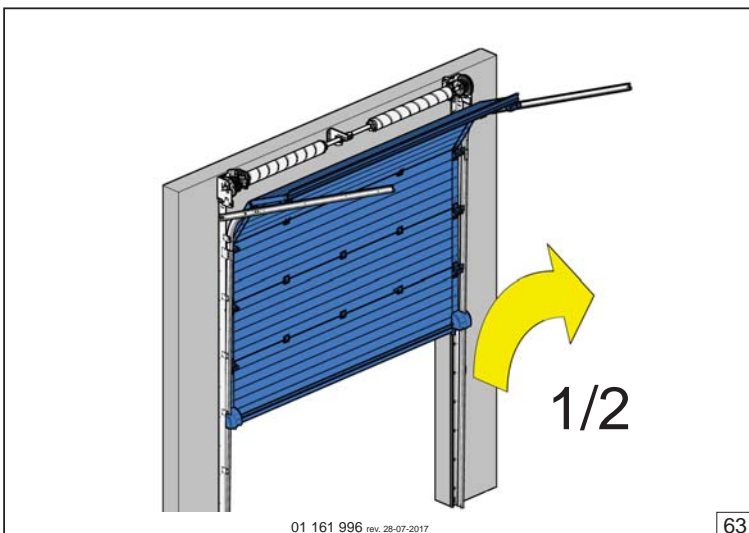
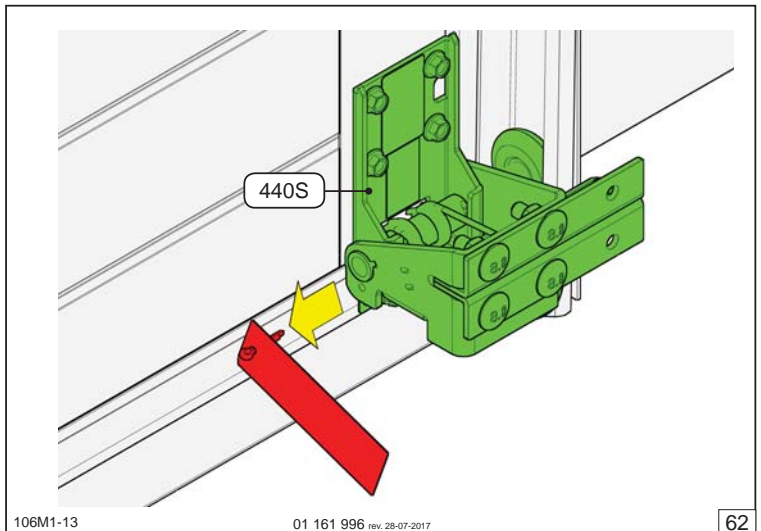
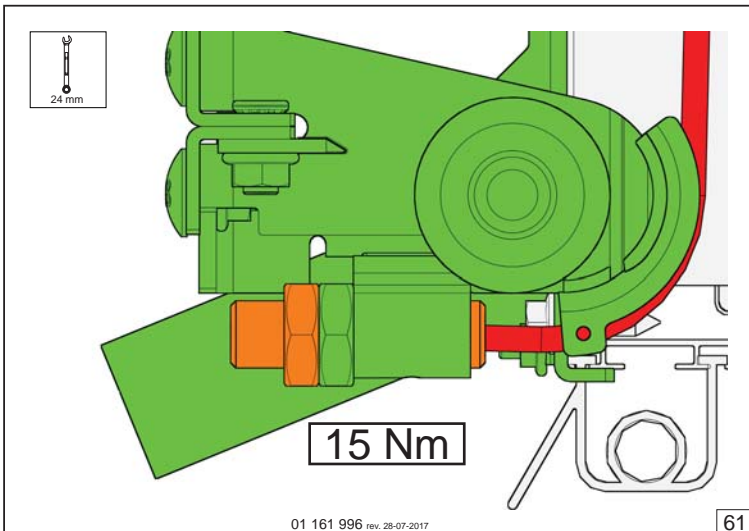
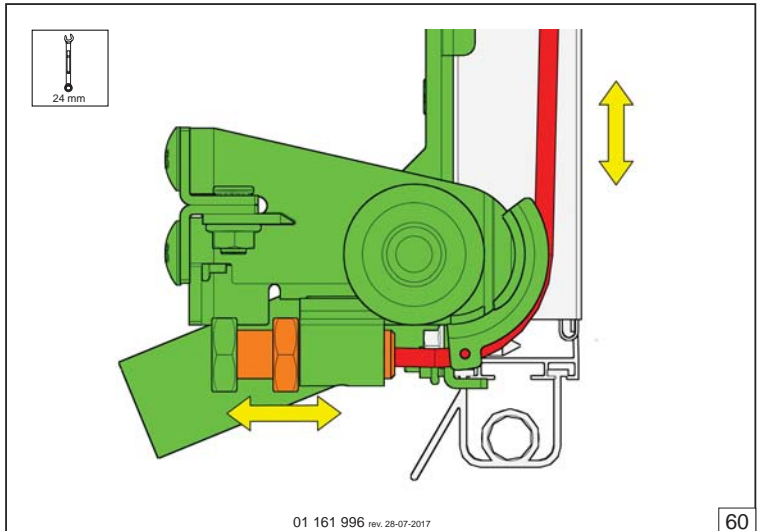
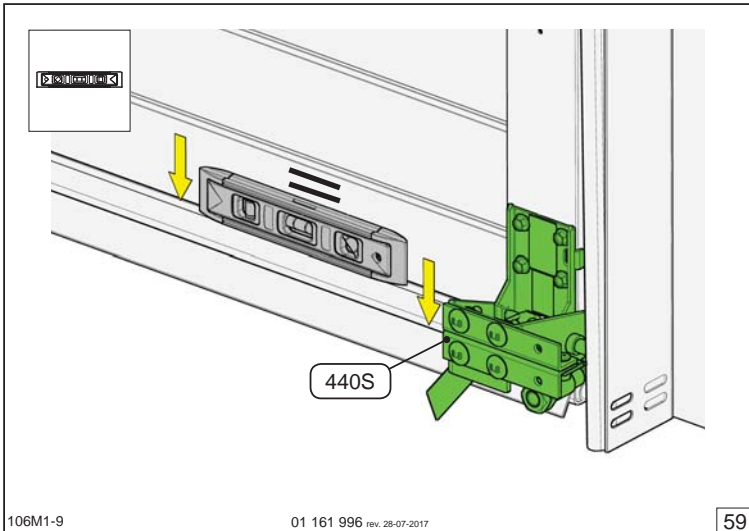
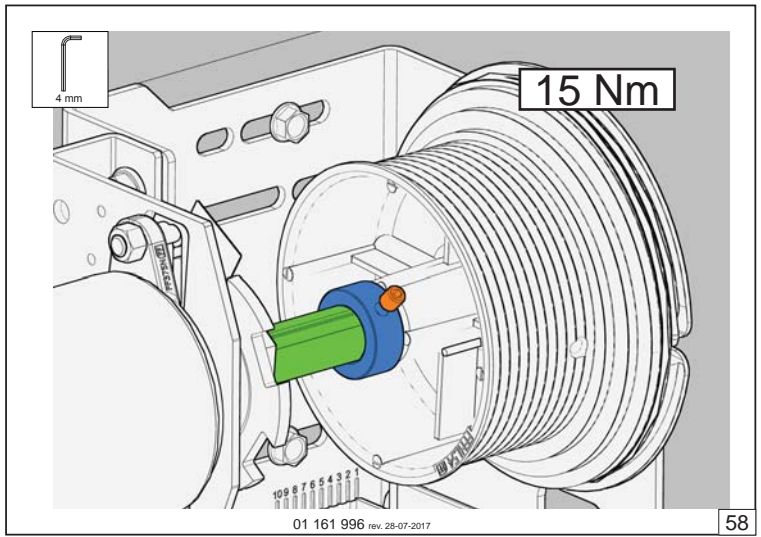
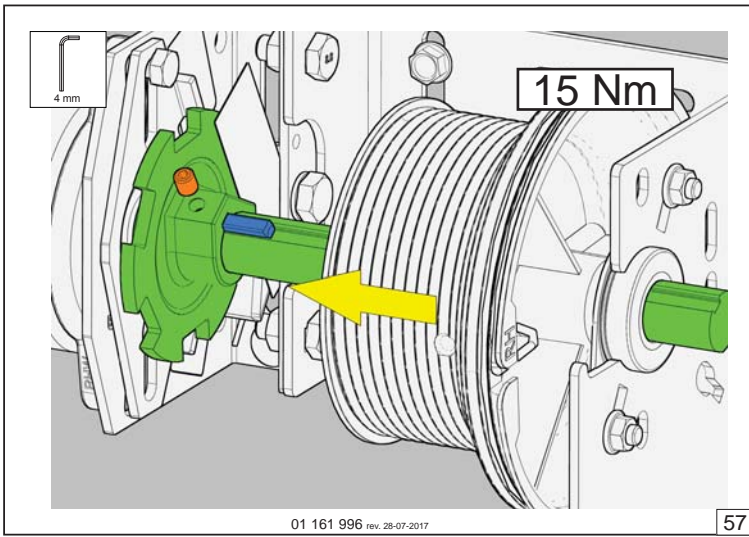

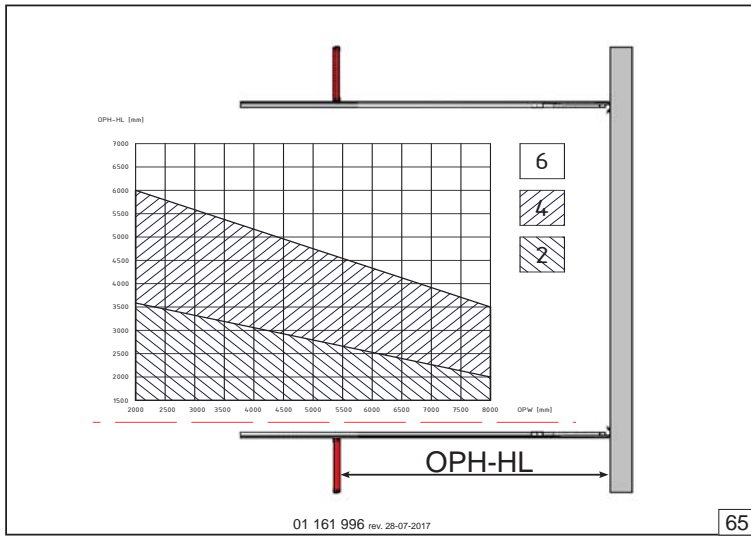

65

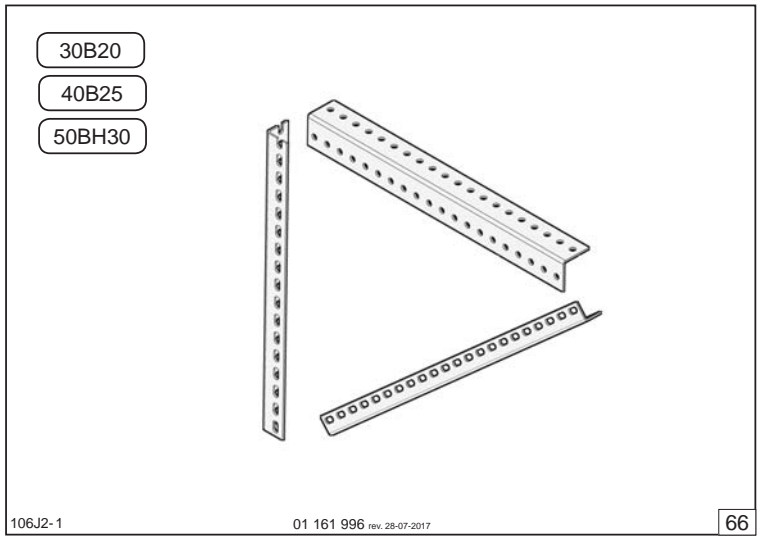

66

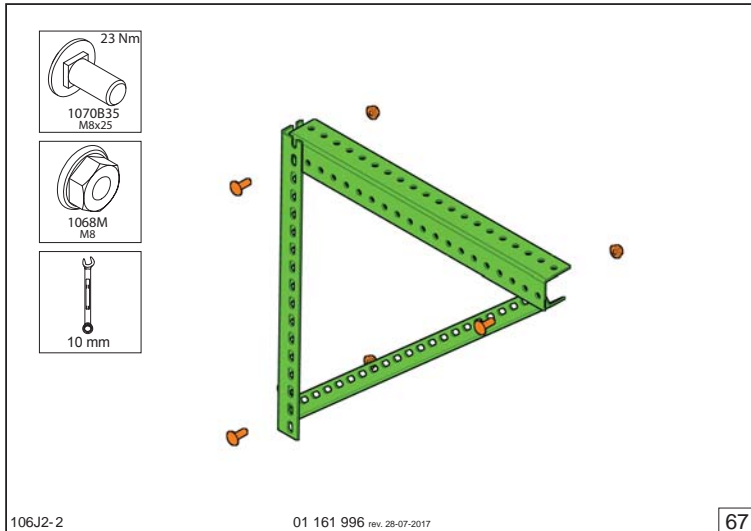

106J2-2

67

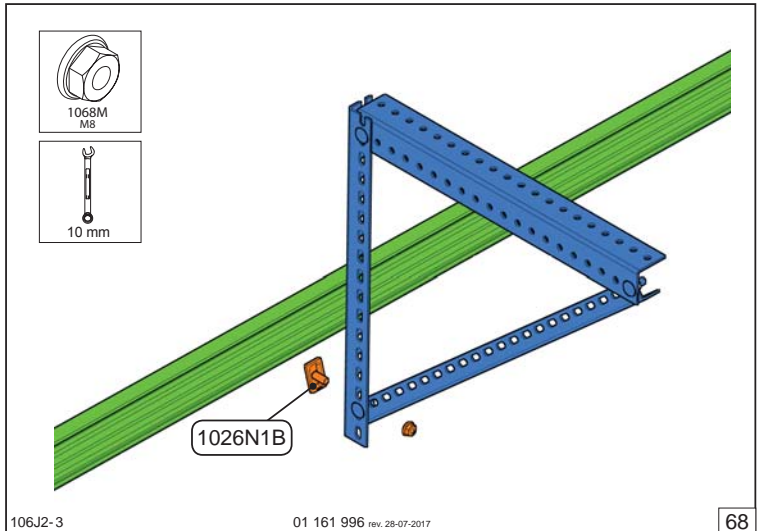

106J2-3

68

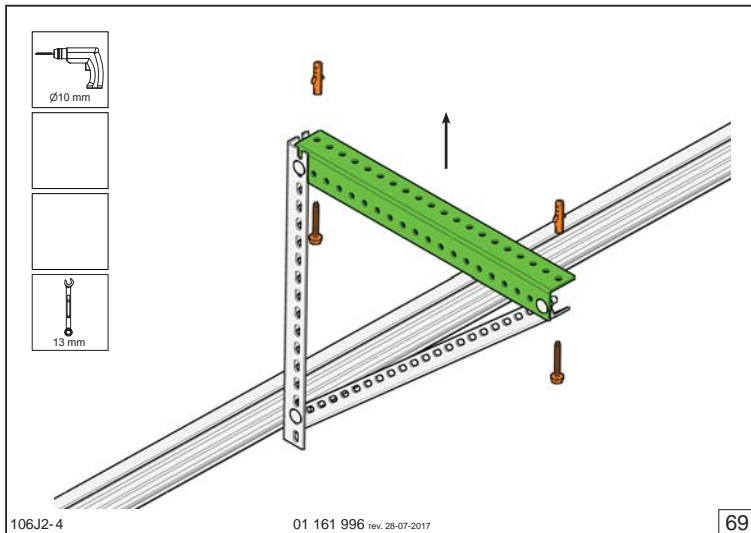

106J2-4

69

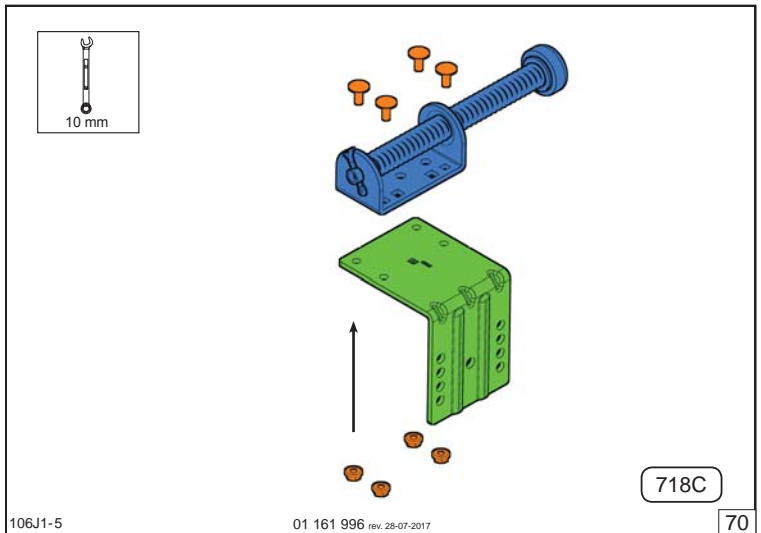

106J1-5

70

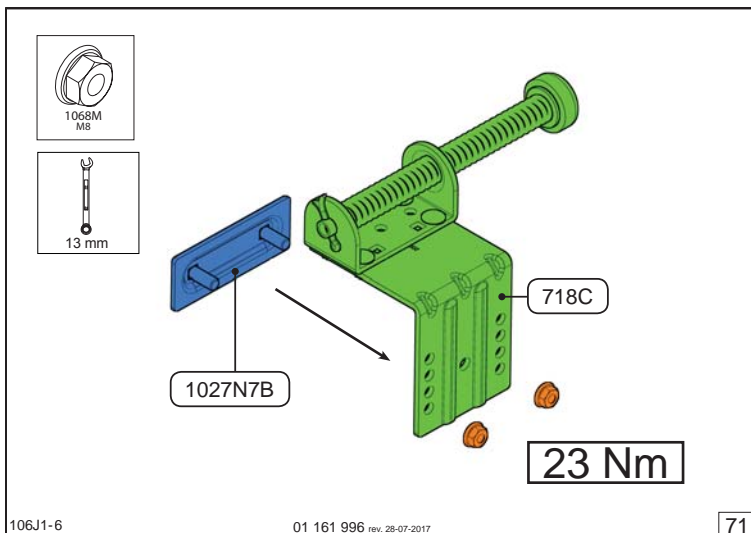

106J1-6

71

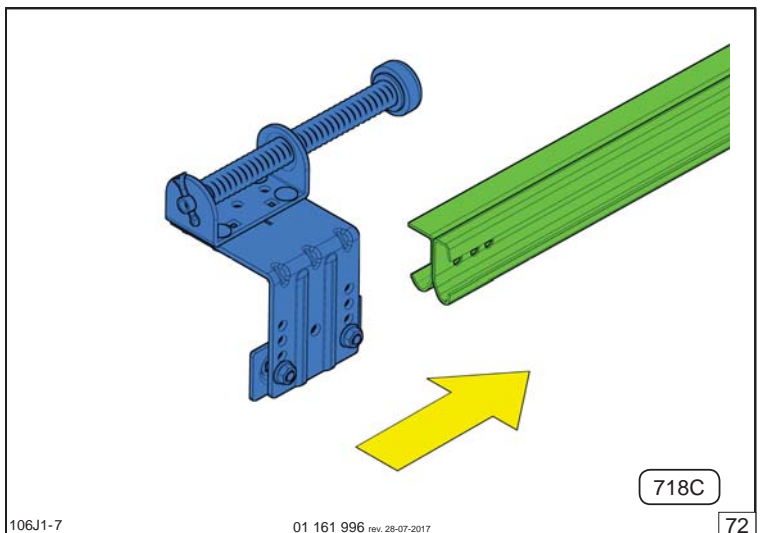

106J1-7

72

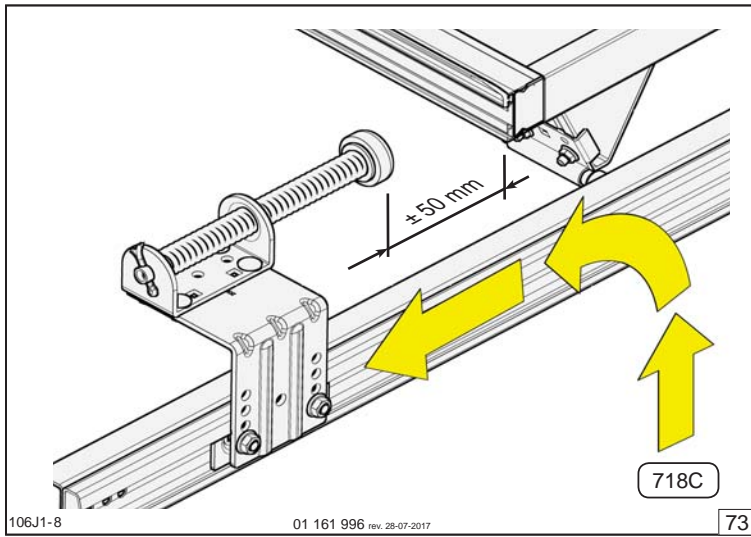

106J1-8

01 161 996 rev. 28-07-2017

73

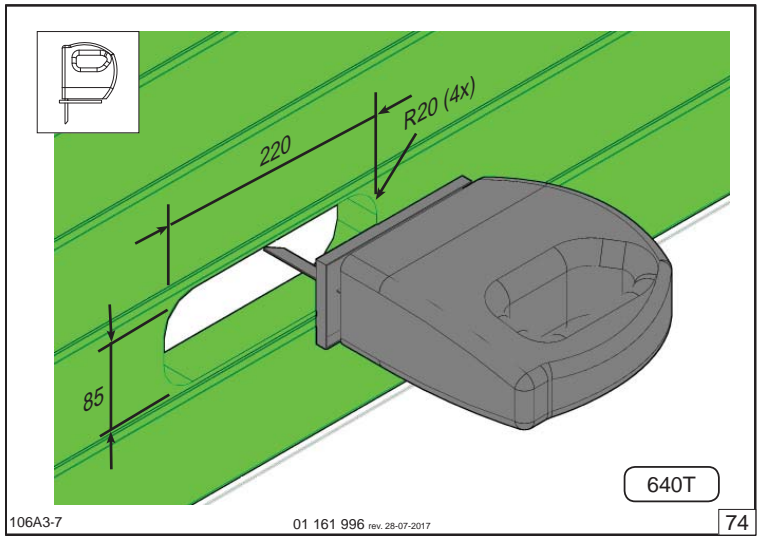

106A3-7

01 161 996 rev. 28-07-2017

74

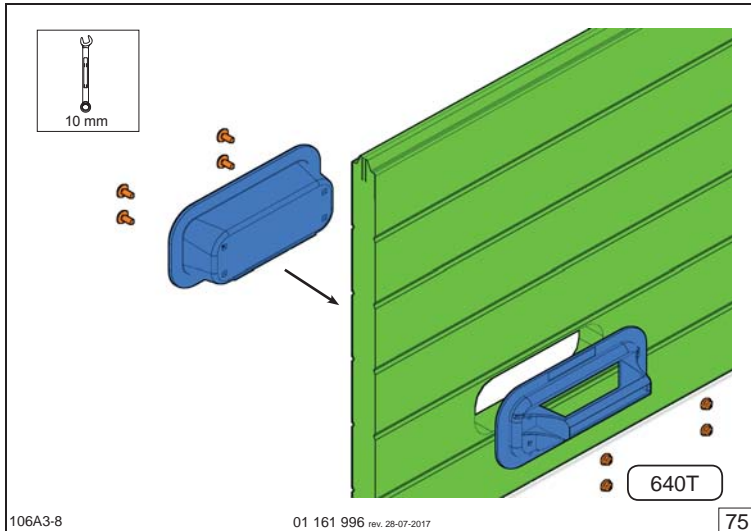

106A3-8

01 161 996 rev. 28-07-2017

75

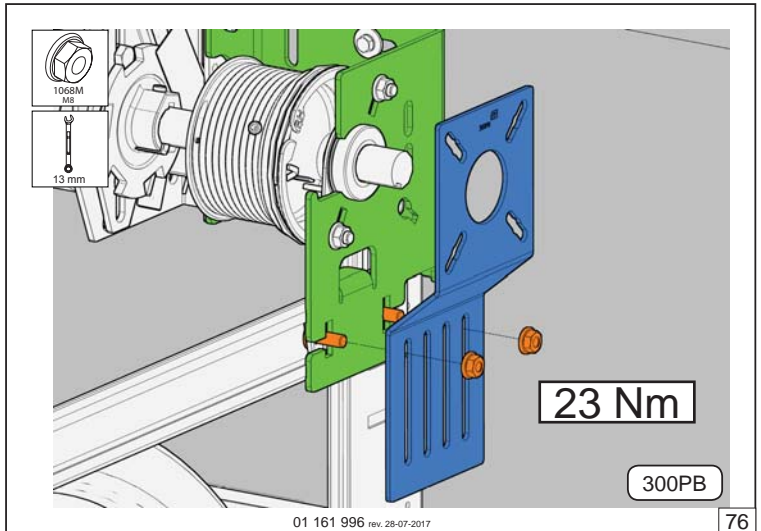

106A3-7

01 161 996 rev. 28-07-2017

76

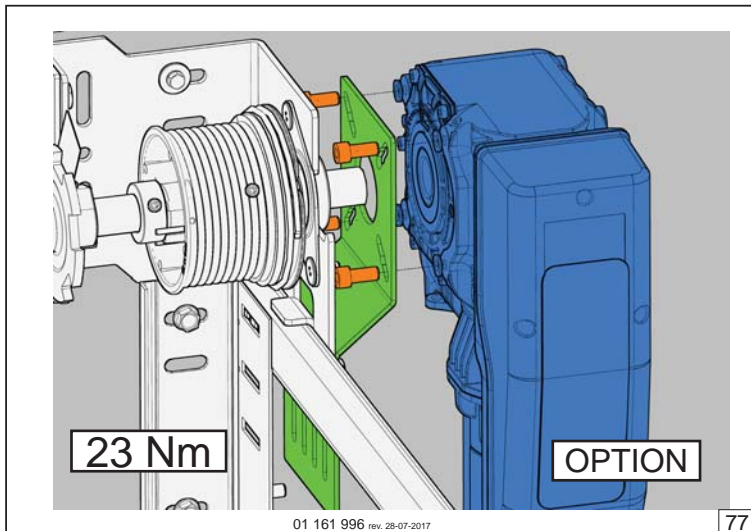

01 161 996 rev. 28-07-2017

77

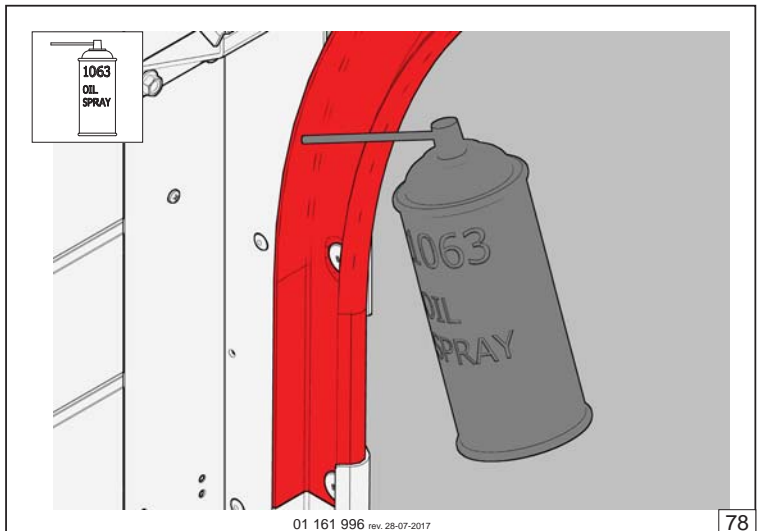

01 161 996 rev. 28-07-2017

78



01 161 996 rev. 28-07-2017

79

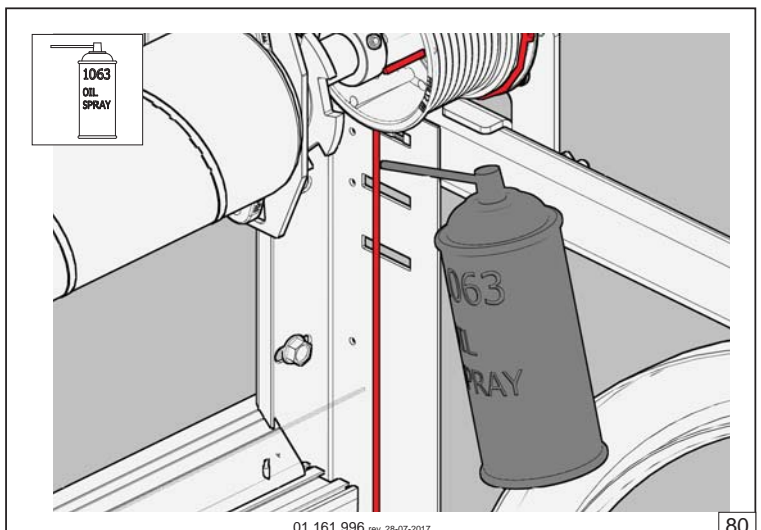

01 161 996 rev. 28-07-2017

80

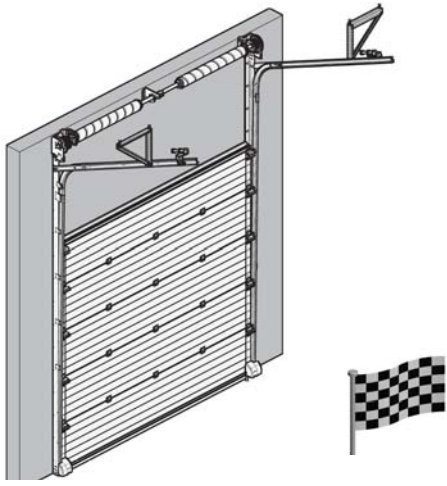

01 161 996 rev. 28-07-2017