



- EN** Assembly manual of standard doorset system (Original instructions)
- IT** Manuale di assemblaggio per sistema serramento standard (Istruzioni originali)
- DE** Montageanleitung für Standardprofilssysteme (Originalsprachlichen Anweisungen)
- FR** Manuel d'assemblage pour système d'huissierie standard (Instructions originales)
- ES** Manual de montaje para sistema de cierre estándar (Instrucciones originales)
- PT** Manual de montagem para sistema de ferragem padrão (Instruções originais)

Ditec PAM30STD

IP2275 • 2017-04-30

Index

	EN	IT	DE	FR	ES	PT
1.	General safety precautions	Avvertenze generali per la sicurezza	Allgemeine Sicherheitshinweise	Consignes générales de sécurité	Advertencias generales de seguridad	Advertências gerais para a segurança
2.	Operating instruction	Indicazioni di utilizzo	Hinweise zum Gebrauch	Indications d'utilisation	Instrucciones de uso	Indicações de uso
3.	Entrance/Exit door frame Ditec PAM30 Series	Serramento di entrata/uscita serie Ditec PAM30	Eingangs-/Ausgangsprofil – Baureihe Ditec PAM30	Huisserie d'entrée/sortie – Série Ditec PAM30	Cierre de entrada/salida – Serie Ditec PAM30	Ferragem de entrada/saída – Série Ditec PAM30
4.	Legend	Legenda	Zeichenerklärung	Légende	Leyenda	Legenda
5.	Profiles shape	Sagomario	Profilgebung	Profilés	Catálogo de perfiles	Moldagem
6.	Accessories	Accessori	Zubehör	Accessoires	Accesorios	Acessórios
7.	Glass thickness	Spessori vetro	Dicke der Scheiben	Epaisseur des vitres	Espesor cristales	Espessura dos vidros
8.	Applications	Applicazioni	Anwendungen	Applications	Aplicaciones	Aplicações
9.	Vertical and horizontal section of 1 moving door wing with right-hand opening (standard version)	Sezione verticale e orizzontale 1 anta mobile con apertura a destra (versione standard)	Vertikal- und Horizontalschnitt für 1 Fahrflügel mit Rechtsöffnung (Vollversion)	Section verticale et horizontale 1 vantail mobile avec ouverture à droite (version standard)	Sección vertical y horizontal de 1 hoja móvil con apertura a la derecha (versión standard)	Secção vertical e horizontal de 1 folha móvel com abertura à direita (versão standard)
10.	Vertical and horizontal section of 1 moving door wing with right-hand opening installed within doorway (standard version)	Sezione verticale e orizzontale 1 anta mobile con apertura a destra, installata in luce (versione standard)	Vertikal- und Horizontalschnitt für 1 Fahrflügel mit Rechtsöffnung, Installation in der Lichte (französische Version)	Section verticale et horizontale 1 vantail mobile avec ouverture à droite, montage sous linteau (version standard)	Sección vertical y horizontal de 1 hoja móvil con apertura a la derecha instalada en luz (versión estándar)	Secção vertical e horizontal de 1 folha móvel com abertura à direita, instalada em vão (versão standard)
11.	Vertical and horizontal section of 1 moving door wing with left-hand opening (standard version)	Sezione verticale e orizzontale 1 anta mobile con apertura a sinistra (versione standard)	Vertikal- und Horizontalschnitt für 1 Fahrflügel mit Linksöffnung (Vollversion)	Section verticale et horizontale 1 vantail mobile avec ouverture à gauche (version standard)	Sección vertical y horizontal de 1 hoja móvil con apertura a la izquierda (versión standard)	Secção vertical e horizontal de 1 folha móvel com abertura à esquerda (versão standard)
12.	Vertical and horizontal section of 1 moving door wing with left-hand opening (standard version)	Sezione verticale e orizzontale 1 anta mobile con apertura a sinistra, installata in luce (versione standard)	Vertikal- und Horizontalschnitt für 1 Fahrflügel mit Linksöffnung, Installation in der Lichte (Vollversion)	Section verticale et horizontale 1 vantail mobile avec ouverture à gauche, montage sous linteau (version standard)	Sección vertical y horizontal de 1 hoja móvil con apertura a la izquierda instalada en luz (versión estándar)	Secção vertical e horizontal de 1 folha móvel com abertura à esquerda, instalada em ombreira (versão standard)
13.	Vertical and horizontal section of 1 moving door wing with right-hand opening (french version)	Sezione verticale e orizzontale 1 anta mobile con apertura a destra (versione francese)	Vertikal- und Horizontalschnitt für 1 Fahrflügel mit Rechtsöffnung (französische Version)	Section verticale et horizontale 1 vantail mobile avec ouverture à droite (version française)	Sección vertical y horizontal de 1 hoja móvil con apertura a la derecha (versión francés)	Secção vertical e horizontal de 1 folha móvel com abertura à direita (versão francesa)
14.	Vertical and horizontal section of 1 moving door wing with right-hand opening installed within doorway (french version)	Sezione verticale e orizzontale 1 anta mobile con apertura a destra, installata in luce (versione francese)	Vertikal- und Horizontalschnitt für 1 Fahrflügel mit Rechtsöffnung, Installation in der Lichte (französische Version)	Section verticale et horizontale 1 vantail mobile avec ouverture à droite, montage sous linteau (version française)	Sección vertical y horizontal de 1 hoja móvil con apertura a la derecha instalada en luz (versión francés)	Secção vertical e horizontal de 1 folha móvel com abertura à direita, instalada em vão (versão francesa)
15.	Vertical and horizontal section of 1 moving door wing with left-hand opening (french version)	Sezione verticale e orizzontale 1 anta mobile con apertura a sinistra (versione Francese)	Vertikal- und Horizontalschnitt für 1 Fahrflügel mit Linksöffnung (französische Version)	Section verticale et horizontale 1 vantail mobile avec ouverture à gauche (version française)	Sección vertical y horizontal de 1 hoja móvil con apertura a la izquierda (versión francés)	Secção vertical e horizontal de 1 folha móvel com abertura à esquerda (versão francesa)
16.	Vertical and horizontal section of 1 moving door wing with left-hand opening installed within doorway (french version)	Sezione verticale e orizzontale 1 anta mobile con apertura a sinistra, installata in luce (versione francese)	Vertikal- und Horizontalschnitt für 1 Fahrflügel mit Linksöffnung, Installation in der Lichte (französische Version)	Section verticale et horizontale 1 vantail mobile avec ouverture à gauche, montage sous linteau (version française)	Sección vertical y horizontal de 1 hoja móvil con apertura a la izquierda instalada en luz (versión francés)	Secção vertical e horizontal de 1 folha móvel com abertura à esquerda, instalada em vão (versão francesa)
17.	Vertical and horizontal section of 1 moving door wing with beam with right-hand opening (standard version)	Sezione verticale e orizzontale 1 anta mobile con apertura a destra e trave di supporto (versione standard)	Vertikal- und Horizontalschnitt für 1 Fahrflügel mit Rechtsöffnung und Stützträger (Vollversion)	Section verticale et horizontale 1 vantail mobile avec ouverture à droite et poutre de soutien (version standard)	Sección vertical y horizontal de 1 hoja móvil con apertura a la derecha y viga de soporte (versión estándar)	Secção vertical e horizontal de 1 folha móvel com abertura à direita e trave de suporte (versão standard)
18.	Vertical and horizontal section of 1 moving door wing with beam with right-hand opening installed within doorway (standard version)	Sezione verticale e orizzontale 1 anta mobile con apertura a destra e trave di supporto, installata in luce (versione standard)	Vertikal- und Horizontalschnitt für 1 Fahrflügel mit Rechtsöffnung und Stützträger, Installation in der Lichte (Vollversion)	Section verticale et horizontale 1 vantail mobile avec ouverture à droite et poutre de soutien, montage sous linteau (version standard)	Sección vertical y horizontal de 1 hoja móvil con apertura a la derecha y viga de soporte instalada en luz (versión estándar)	Secção vertical e horizontal de 1 folha móvel com abertura à direita e trave de suporte, instalada em vão (versão standard)

	EN	IT	DE	FR	ES	PT
19.	Vertical and horizontal section of 1 moving door wing with beam with left-hand opening (standard version)	Sezione verticale e orizzontale 1 anta mobile con apertura a sinistra e trave di supporto (versione standard)	Vertikal- und Horizontalschnitt für 1 Fahrflügel mit Linksöffnung und Stützträger (Vollversion)	Section verticale et horizontale 1 vantail mobile avec ouverture à gauche et poutre de soutien (version standard)	Sección vertical y horizontal de 1 hoja móvil con apertura a la izquierda y viga de soporte (versión estándar)	Secção vertical e horizontal de 1 folha móvel com abertura à esquerda e trave de suporte (versão standard)
20.	Vertical and horizontal section of 1 moving door wing with beam with left-hand opening installed within doorway (standard version)	Sezione verticale e orizzontale 1 anta mobile con apertura a sinistra e trave di supporto, installata in luce (versione standard)	Vertikal- und Horizontalschnitt für 1 Fahrflügel mit Linksöffnung und Stützträger, Installation in der Lichte (Vollversion)	Section verticale et horizontale 1 vantail mobile avec ouverture à gauche et poutre de soutien, montage sous linteau (version standard)	Sección vertical y horizontal de 1 hoja móvil con apertura a la izquierda y viga de soporte instalada en luz (versión estándar)	Secção vertical e horizontal de 1 folha móvel com abertura à esquerda e trave de suporte, instalada em vão (versão standard)
21.	Vertical and horizontal section of 1 moving door wing with right-hand opening and overlight (standard version)	Sezione verticale e orizzontale 1 anta mobile con apertura a destra e sopra luce (versione standard)	Vertikal- und Horizontalschnitt für 1 Fahrflügel mit Rechtsöffnung und Oberlicht (Vollversion)	Section verticale et horizontale 1 vantail mobile avec ouverture à droite et imposte (version standard)	Sección vertical y horizontal de 1 hoja móvil con apertura a la derecha y acristalado (versión standard)	Secção vertical e horizontal de 1 folha móvel com abertura à direita e bandeira (versão standard)
22.	Vertical and horizontal section of 1 moving door wing with right-hand opening installed within doorway and overlight (standard version)	Sezione verticale e orizzontale 1 anta mobile con apertura a destra e sopra luce, installata in luce (versione standard)	Vertikal- und Horizontalschnitt für 1 Fahrflügel mit Rechtsöffnung und Oberlicht, Installation in der Lichte (Vollversion)	Section verticale et horizontale 1 vantail mobile avec ouverture à droite et imposte, montage sous linteau (version standard)	Sección vertical y horizontal de 1 hoja móvil con apertura a la derecha y acristalado instalada en luz (versión estándar)	Secção vertical e horizontal de 1 folha móvel com abertura à direita e bandeira, instalada em vão (versão standard)
23.	Vertical and horizontal section of 1 moving door wing with left-hand opening and overlight (standard version)	Sezione verticale e orizzontale una anta mobile con apertura a sinistra e sopra luce (versione standard)	Vertikal- und Horizontalschnitt für 1 Fahrflügel mit Linksöffnung und Oberlicht (Vollversion)	Section verticale et horizontale 1 vantail mobile avec ouverture à gauche et imposte (version standard)	Sección vertical y horizontal de una hoja móvil con apertura a la izquierda y acristalado (versión standard)	Secção vertical e horizontal de 1 folha móvel com abertura à esquerda e bandeira (versão standard)
24.	Vertical and horizontal section of 1 moving door wing with left-hand opening installed within doorway and overlight (standard version)	Sezione verticale e orizzontale 1 anta mobile con apertura a sinistra e sopra luce, installata in luce (versione standard)	Vertikal- und Horizontalschnitt für 1 Fahrflügel mit Linksöffnung und Oberlicht, Installation in der Lichte (Vollversion)	Section verticale et horizontale 1 vantail mobile avec ouverture à gauche et imposte, montage sous linteau (version standard)	Sección vertical y horizontal de 1 hoja móvil con apertura a la izquierda instalada en luz (versión estándar)	Secção vertical e horizontal de 1 folha móvel com abertura à esquerda e bandeira, instalada em vão (versão standard)
25.	Vertical and horizontal section of 1 moving door wing and 1 fixed door wing with right-hand opening (french version)	Sezione verticale e orizzontale una anta mobile con apertura a destra e una anta fissa (versione francese)	Vertikal- und Horizontalschnitt für 1 Fahrflügel mit Rechtsöffnung und einem Stehflügel (französische Version)	Section verticale et horizontale un vantail mobile avec ouverture à droite et un vantail fixe (version française)	Sección vertical y horizontal de una hoja móvil con apertura a la derecha y una hoja fija (versión francés)	Secção vertical e horizontal de 1 folha móvel com abertura à direita e 1 folha fixa, (versão francesa)
26.	Vertical and horizontal section of 1 moving door wing and 1 fixed door wing with right-hand opening installed within doorway (french version)	Sezione verticale e orizzontale 1 anta mobile con apertura a destra e una anta fissa, installata in luce (versione francese)	Vertikal- und Horizontalschnitt für 1 Fahrflügel mit Rechtsöffnung und einem Stehflügel, Installation in der Lichte (französische Version)	Section verticale et horizontale 1 vantail mobile avec ouverture à droite et un vantail fixe, montage sous linteau (version française)	Sección vertical y horizontal de 1 hoja móvil con apertura a la derecha y una hoja fija instalada en luz (versión francés)	Secção vertical e horizontal de 1 folha móvel com abertura à direita e 1 folha fixa, instalada em ombreira (versão francesa)
27.	Vertical and horizontal section of 1 moving door wing and 1 fixed door wing with left-hand opening (french version)	Sezione verticale e orizzontale una anta mobile con apertura a sinistra e una anta fissa (versione francese)	Vertikal- und Horizontalschnitt für 1 Fahrflügel mit Linksöffnung und einem Stehflügel (französische Version)	Section verticale et horizontale un vantail mobile avec ouverture à gauche et un vantail fixe (version française)	Sección vertical y horizontal de una hoja móvil con apertura a la izquierda y una hoja fija (versión francés)	Secção vertical e horizontal de 1 folha móvel com abertura à esquerda e 1 folha fixa (versão francesa)
28.	Vertical and horizontal section of 1 moving door wing and 1 fixed door wing with left-hand opening installed within doorway (french version)	Sezione verticale e orizzontale 1 anta mobile con apertura a sinistra e 1 anta fissa, installata in luce (versione francese)	Vertikal- und Horizontalschnitt für 1 Fahrflügel mit Linksöffnung und einem Stehflügel, Installation in der Lichte (französische Version)	Section verticale et horizontale 1 vantail mobile avec ouverture à gauche et 1 vantail fixe, montage sous linteau (version française)	Sección vertical y horizontal de 1 hoja móvil con apertura a la izquierda y 1 hoja fija instalada en luz (versión francés)	Secção vertical e horizontal de 1 folha móvel com abertura à esquerda e 1 folha fixa, instalada em vão (versão francesa)
29.	Vertical and horizontal section of 1 moving door wing and 1 fixed door wing with beam with right-hand opening (standard version)	Sezione verticale e orizzontale 1 anta mobile con apertura a destra, 1 anta fissa e trave di supporto, installata in luce (versione standard)	Vertikal- und Horizontalschnitt für 1 Fahrflügel mit Rechtsöffnung, 1 Stehflügel und Stützträger, Installation in der Lichte (Vollversion)	Section verticale et horizontale 1 vantail mobile avec ouverture à droite, 1 vantail fixe et poutre de soutien, montage sous linteau (version standard)	Sección vertical y horizontal de 1 hoja móvil con apertura a la derecha, 1 hoja fija y viga de soporte instalada en luz (versión estándar)	Secção vertical e horizontal de 1 folha móvel com abertura à direita, 1 folha fixa e trave de suporte, instalada em vão (versão standard)
30.	Vertical and horizontal section of 1 moving door wing and 1 fixed door wing with beam with left-hand opening (standard version)	Sezione verticale e orizzontale 1 anta mobile con apertura a sinistra, 1 anta fissa e trave di supporto, installata in luce (versione standard)	Vertikal- und Horizontalschnitt für 1 Fahrflügel mit Linksöffnung, 1 Stehflügel und Stützträger, Installation in der Lichte (Vollversion)	Section verticale et horizontale 1 vantail mobile avec ouverture à gauche, 1 vantail fixe et poutre de soutien, montage sous linteau (version standard)	Sección vertical y horizontal de 1 hoja móvil con apertura a la izquierda, 1 hoja fija y viga de soporte instalada en luz (versión estándar)	Secção vertical e horizontal de 1 folha móvel com abertura à esquerda, 1 folha fixa e trave de suporte, instalada em vão (versão standard)

	EN	IT	DE	FR	ES	PT
31.	Vertical and horizontal section of 1 moving door wing and 1 fixed door wing with beam with right-hand opening (french version)	Sezione verticale e orizzontale 1 anta mobile con apertura a destra, 1 anta fissa e trave di supporto, installata in luce (versione francese)	Vertikal- und Horizontalschnitt für 1 Fahrflügel mit Rechtsöffnung, 1 Stehflügel und Stützträger, Installation in der Lichte (französische Version)	Section verticale et horizontale 1 vantail mobile avec ouverture à droite, 1 vantail fixe et poutre de soutien, montage sous linteau (version française)	Sección vertical y horizontal de 1 hoja móvil con apertura a la derecha, 1 hoja fija y viga de soporte instalada en luz (versión francés)	Secção vertical e horizontal de 1 folha móvel com abertura à direita, 1 folha fixa e trave de suporte, instalada em vão (versão francesa)
32.	Vertical and horizontal section of 1 moving door wing and 1 fixed door wing with beam with left-hand opening (french version)	Sezione verticale e orizzontale 1 anta mobile con apertura a sinistra, 1 anta fissa e trave di supporto, installata in luce (versione francese)	Vertikal- und Horizontalschnitt für 1 Fahrflügel mit Linksöffnung, 1 Stehflügel und Stützträger, Installation in der Lichte (französische Version)	Section verticale et horizontale 1 vantail mobile avec ouverture à gauche, 1 vantail fixe et poutre de soutien, montage sous linteau (version française)	Sección vertical y horizontal de 1 hoja móvil con apertura a la izquierda, 1 hoja fija y viga de soporte instalada en luz (versión francés)	Secção vertical e horizontal de 1 folha móvel com abertura à esquerda, 1 folha fixa e trave de suporte, instalada em vão (versão francesa)
33.	Vertical and horizontal section of 1 moving door wing and 1 fixed door wing with right-hand opening and overlight (standard version)	Sezione verticale e orizzontale una anta mobile con apertura a destra, una anta fissa e sopra luce, installata in luce (versione standard)	Vertikal- und Horizontalschnitt für 1 Fahrflügel mit Rechtsöffnung, 1 Stehflügel und Oberlicht, Installation in der Lichte (Vollversion)	Section verticale et horizontale un vantail mobile avec ouverture à droite, un vantail fixe et imposte, montage sous linteau (version standard)	Sección vertical y horizontal de una hoja móvil con apertura a la derecha, una hoja fija y acristalado instalada en luz (versión estándar)	Secção vertical e horizontal de 1 folha móvel com abertura à direita, 1 folha fixa e bandeira, instalada em vão (versão standard)
34.	Vertical and horizontal section of 1 moving door wing and 1 fixed door wing with left-hand opening and overlight (standard version)	Sezione verticale e orizzontale 1 anta mobile con apertura a sinistra, 1 anta fissa e sopra luce, installata in luce (versione standard)	Vertikal- und Horizontalschnitt für 1 Fahrflügel mit Linksöffnung, 1 Stehflügel und Oberlicht, Installation in der Lichte (Vollversion)	Section verticale et horizontale 1 vantail mobile avec ouverture à gauche, 1 vantail fixe et imposte, montage sous linteau (version standard)	Sección vertical y horizontal de 1 hoja móvil con apertura a la izquierda, 1 hoja fija y acristalado instalada en luz (versión estándar)	Secção vertical e horizontal de 1 folha móvel com abertura à esquerda, 1 folha fixa e bandeira, instalada em vão (versão standard)
35.	Vertical and horizontal section of 1 moving door wing and 1 fixed door wing with right-hand opening and overlight (french version)	Sezione verticale e orizzontale 1 anta mobile con apertura a destra, 1 anta fissa e sopra luce, installata in luce (versione francese)	Vertikal- und Horizontalschnitt für 1 Fahrflügel mit Rechtsöffnung, 1 Stehflügel und Oberlicht, Installation in der Lichte (französische Version)	Section verticale et horizontale 1 vantail mobile avec ouverture à droite, 1 vantail fixe et imposte, montage sous linteau (version française)	Sección vertical y horizontal de 1 hoja móvil con apertura a la derecha, 1 hoja fija y acristalado instalada en luz (versión francés)	Secção vertical e horizontal de 1 folha móvel com abertura à direita, 1 folha fixa e bandeira, instalada em vão (versão francesa)
36.	Vertical and horizontal section of 1 moving door wing and 1 fixed door wing with left-hand opening and overlight (french version)	Sezione verticale e orizzontale 1 anta mobile con apertura a sinistra, 1 anta fissa e sopra luce, installata in luce (versione francese)	Vertikal- und Horizontalschnitt für 1 Fahrflügel mit Linksöffnung, 1 Stehflügel und Oberlicht, Installation in der Lichte (französische Version)	Section verticale et horizontale 1 vantail mobile avec ouverture à gauche, 1 vantail fixe et imposte, montage sous linteau (version française)	Sección vertical y horizontal de 1 hoja móvil con apertura a la izquierda, 1 hoja fija y acristalado instalada en luz (versión francés)	Secção vertical e horizontal de 1 folha móvel com abertura à esquerda, 1 folha fixa e bandeira, instalada em vão (versão francesa)
37.	Vertical and horizontal section of 2 moving door wings (standard version)	Sezione verticale e orizzontale 2 ante mobili (versione standard)	Vertikal- und Horizontalschnitt für 2 Fahrflügel (Vollversion)	Section verticale et horizontale 2 vantaux mobiles (version standard)	Sección vertical y horizontal de 2 hojas móviles (versión standard)	Secção vertical e horizontal de 2 folhas móveis (versão standard)
38.	Vertical and horizontal section of 2 moving door wings (french version)	Sezione verticale e orizzontale 2 ante mobili (versione francese)	Vertikal- und Horizontalschnitt für 2 Fahrflügel (französische Version)	Section verticale et horizontale 2 vantaux mobiles (version française)	Sección vertical y horizontal de 2 hojas móviles (versión francés)	Secção vertical e horizontal de 2 folhas móveis (versão francesa)
39.	Vertical and horizontal section of 2 moving door wings with beam (standard version)	Sezione verticale e orizzontale 2 ante mobili e trave di supporto (versione standard)	Vertikal- und Horizontalschnitt für 2 Fahrflügel und Stützträger (Vollversion)	Section verticale et horizontale 2 vantaux mobiles et poutre de soutien (version standard)	Sección vertical y horizontal de 2 hojas móviles y viga de soporte (versión standard)	Secção vertical e horizontal de 2 folhas móveis e trave de suporte (versão standard)
40.	Vertical and horizontal section of 2 moving door wings with overlight (standard version)	Sezione verticale e orizzontale 2 ante mobili e sopra luce (versione standard)	Vertikal- und Horizontalschnitt für 2 Fahrflügel und Oberlicht (Vollversion)	Section verticale et horizontale 2 vantaux mobiles et imposte (version standard)	Sección vertical y horizontal de 2 hojas móviles y acristalado (versión standard)	Secção vertical e horizontal de 2 folhas móveis e bandeira (versão standard)
41.	Vertical and horizontal section of 2 moving door wings and 2 fixed door wings with beam (standard version)	Sezione verticale e orizzontale 2 ante mobili, 2 ante fisse e trave di supporto (versione standard)	Vertikal- und Horizontalschnitt für 2 Fahrflügel, 2 Stehflügel und Stützträger (Vollversion)	Section verticale et horizontale 2 vantaux mobiles, 2 vantaux fixes et poutre de soutien (version standard)	Sección vertical y horizontal de 2 hojas móviles, 2 hojas fijas y viga de soporte (versión standard)	Secção vertical e horizontal de 2 folhas móveis, 2 folhas fixas e trave de suporte (versão standard)
42.	Vertical and horizontal section of 2 moving door wings and 2 fixed door wings (french version)	Sezione verticale e orizzontale 2 ante mobili, 2 ante fisse (versione francese)	Vertikal- und Horizontalschnitt für 2 Fahrflügel und 2 Stehflügel (französische Version)	Section verticale et horizontale 2 vantaux mobiles, 2 vantaux fixes (version française)	Sección vertical y horizontal de 2 hojas móviles y 2 hojas fijas (versión francés)	Secção vertical e horizontal de 2 folhas móveis, 2 folhas fixas (versão francesa)
43.	Vertical and horizontal section of 2 moving door wings and 2 fixed door wings with beam (french version)	Sezione verticale e orizzontale 2 ante mobili, 2 ante fisse e trave di supporto (versione francese)	Vertikal- und Horizontalschnitt für 2 Fahrflügel, 2 Stehflügel und Stützträger (französische Version)	Section verticale et horizontale 2 vantaux mobiles, 2 vantaux fixes et poutre de soutien (version française)	Sección vertical y horizontal de 2 hojas móviles, 2 hojas fijas y viga de soporte (versión francés)	Secção vertical e horizontal de 2 folhas móveis, 2 folhas fixas e trave de suporte (versão francesa)

	EN	IT	DE	FR	ES	PT
44.	Vertical and horizontal section of 2 moving door wings and 2 fixed door wings with overlight (standard version)	Sezione verticale e orizzontale 2 ante mobili, 2 ante fisse e sopra luce (versione standard)	Vertikal- und Horizontalschnitt für 2 Fahrflügel, 2 Stehflügel und Oberlicht (Vollversion)	Section verticale et horizontale 2 vantaux mobiles, 2 vantaux fixes et imposte (version standard)	Sección vertical y horizontal de 2 hojas móviles, 2 hojas fijas y acristalado (versión standard)	Secção vertical e horizontal de 2 folhas móveis, 2 folhas fixas e bandeira (versão standard)
45.	Vertical and horizontal section of 2 moving door wings and 2 fixed door wings with overlight (french version)	Sezione verticale e orizzontale 2 ante mobili, 2 ante fisse e sopra luce (versione francese)	Vertikal- und Horizontalschnitt für 2 Fahrflügel, 2 Stehflügel und Oberlicht (französische Version)	Section verticale et horizontale 2 vantaux mobiles, 2 vantaux fixes et imposte (version française)	Sección vertical y horizontal de 2 hojas móviles, 2 hojas fijas y acristalado (versión francés)	Secção vertical e horizontal de 2 folhas móveis, 2 folhas fixas e bandeira (versão francesa)
46.	Technical sections	Sezioni tecniche	Technische Querschnitte	Sections techniques	Secciones técnicas	Secções técnicas
47.	Processes	Esplosi	Explosionszeichnungen	Schémas éclatés	Despieces	Vista explodida
48.	Details of additional dimensions	Dettagli quote aggiuntive di riferimento	Details von zusätzlichen Dimensionen	Détails parts additionnelles de référence	Detallas cuotas adicionales de referencia	Detalhes de dimensões adicionais
49.	Installation instructions	Istruzioni di installazione	Installationsanleitung	Instructions d'installation	Instrucciones de instalación	Instruções de instalação



This symbol indicates instructions or notes regarding safety, to which special attention must be paid.



This symbol indicates useful information for the correct functioning of the product.

1. General safety precautions



This assembly and installation manual is intended for qualified personnel only.

Read the instructions carefully before installing the product.

Bad installation could be dangerous.

Use original spare parts only for repairs or replacements of products.



The packaging materials (plastic, polystyrene, etc.) should not be discarded in the environment or left within reach of children, as these are a potential source of danger.

The PAM30 door frame system complies with the essential requirements of the following standards:

EN 16005 European Standard - Safety in use of power operated pedestrian door sets

Standard DIN 18650-1 - Standard DIN 18650-2

Drawings of all standard typologies are available in graphic format for CAD environments (dwg) and image format (pdf) at <http://www.ditecentrematic.com/download>.

2. Operating instructions

The tests carried out in the laboratory and onsite indicate a maximum load of the door wing of 120 kg.

In the sections below, the used formulas take into account the following standard criteria:

- the PLmax door width is considered to be between the uprights of the fixed doors and/or the frame. The effective passage opening has a tolerance of ± 20 mm.
- for every type of door, the reference dimension of the automation is indicated (LT).

3. Entrance/exit door frame – Ditec PAM30 Series

Sliding door made with EN AW 6060 T5 (UNI 9006/1) aluminium alloy extruded profiles

- 30 mm size

- suitable for DITEC automated installations, with special devices that guarantee accident prevention

- surface finish with powder coating (polyester powder in RAL colours- Qualicoat) or anodising (EURAS finishes - Qualanod).

The profile series is equipped to house 8, 10, 22 mm thick glass provided for safe anchoring of the glass and correct adjustment during installation. The system also allows maintenance to be carried out easily if glasses are accidentally damaged or broken.

The door frame is equipped with special EPDM gaskets for the hermetic vertical stop with brush-type seals in the openable horizontal perimeters which give the system optimal temperature and sound proofing performances.

The door frames are designed in a wide range of coded typologies to allow customers to select a solution that suits the type of installation according to the specifications in the Technical Manuals.

The PAM30 series consists of profiles (uprights and crosspieces) with sturdy sections which can be used to create all the typologies Standard with Overlight.



Questo simbolo indica istruzioni o note relative alla sicurezza a cui prestare particolare attenzione.



Questo simbolo indica informazioni utili al corretto funzionamento del prodotto.

1. Avvertenze generali per la sicurezza



Il presente manuale di lavorazione ed assemblaggio è rivolto esclusivamente a personale qualificato.

Leggere attentamente le istruzioni prima di iniziare l'installazione del prodotto.

Una errata installazione può essere fonte di pericolo.

Per l'eventuale riparazione o sostituzione dei prodotti dovranno essere utilizzati esclusivamente ricambi originali.



I materiali dell'imballaggio (plastica, polistirolo, ecc.) non vanno dispersi nell'ambiente e non devono essere lasciati alla portata dei bambini in quanto potenziali fonti di pericolo.

Il sistema di serramenti PAM30 è conforme ai requisiti essenziali delle seguenti Norme:

Norma Europea EN 16005 - La sicurezza in uso delle porte pedonali

Norma DIN 18650-1 - Norma DIN 18650-2

I disegni di tutte le tipologie standard sono disponibili in formato grafico per ambienti CAD (dwg) e in formato immagine (pdf) all'indirizzo <http://www.ditecentrematic.com/download>.

2. Indicazioni di utilizzo

Le prove effettuate in laboratorio ed in sede d'opera conducono ad una portata massima dell'anta di 120 Kg.

Nelle sezioni che seguono le formule adottate tengono conto dei seguenti criteri standard:

- il vano passaggio PLmax viene considerato tra i montanti verticali delle ante fisse e/o della cornice. Il vano passaggio utile ha una tolleranza di ± 20 mm.
- per ogni tipologia di porta viene indicata la dimensione di riferimento dell'automazione (LT).

3. Serramento di ingresso/uscita – Serie Ditec PAM30

Porta scorrevole realizzata con profilati estrusi in lega di alluminio EN AW 6060 (UNI 9006/1) T5

- sezione da mm 30

- adatta ad installazioni automatizzate DITEC, con specifici accorgimenti atti a garantire ogni sicurezza antinfortunistica

- finitura superficiale realizzata con trattamento di verniciatura a forno (polveri in poliestere nei colori RAL- marchio Qualicoat) o di colorazione anodica (finiture EURAS - marchio Qualanod).

La serie di profilati è equipaggiata per alloggiare volumi vetrari di spessore da 8, 10, 22 mm, predisposti per un sicuro ancoraggio delle lastre di vetro e per una corretta regolazione in fase di posa in opera.

Il serramento è corredato di speciali guarnizioni in EPDM per la chiusura verticale centrale e laterale con tenuta ermetica, dotato di guarnizioni a spazzola nei perimetri orizzontali apribili, così da garantire una ottimale prestazione di tenuta termo-acustica del sistema.

Serramenti realizzabili nelle più svariate tipologie codificate onde consentire la scelta idonea al tipo di installazione, attenendosi alle specifiche indicate nei Manuali Tecnici.

La serie PAM30 è composta da profili (montanti e traversi) di robuste sezioni, per realizzazione di tutte le tipologie Standard e con Sopraluce.



Dieses Symbol verweist auf Anweisungen oder Hinweise zur Sicherheit, auf die besonders geachtet werden muss.



Dieses Symbol verweist auf nützliche Informationen für den Betrieb des Produkts.

1. Allgemeine Sicherheitshinweise



Das vorliegende Montage und Installationshandbuch ist ausschließlich für das Fachpersonal bestimmt. Lesen Sie die Anleitungen vor der Montage des Produktes aufmerksam durch. Eine fehlerhafte Montage kann zu Verletzungen und Sachschäden führen. Bei Reparaturen oder Austausch der Produkte dürfen ausschließlich Original-Ersatzteile verwendet werden.



Die Verpackungsmaterialien (Kunststoff, Polystyrol usw.) müssen sachgemäß entsorgt werden und dürfen nicht in Kinderhände gelangen, da sie eine Gefahrenquelle darstellen können.

Das Profilsystem PAM30 entspricht den wesentlichen Anforderungen der folgenden Normen:

Europäische Norm EN 16005 - Nutzungssicherheit kraftbetätigte Türen
Norm DIN 18650-1 - Norm DIN 18650-2

Die Zeichnungen aller Standardtypen sind im Grafikformat für CAD-Umgebungen (dwg) und im Bildformat (pdf) unter der Internetadresse <http://www.ditecentrematic.com/download> erhältlich.

2. Hinweise zum Gebrauch

Die im Labor und vor Ort durchgeführten Tests ergeben eine maximale Tragfähigkeit des Flügels von 120 kg.

Die in den folgenden Abschnitten angewandten Formeln beziehen sich auf die folgenden Standardkriterien:

- die lichte Öffnung PL_{max} wird zwischen den Seitenpfosten der Seitenteile und/oder des Rahmens berücksichtigt. Die nutzbare lichte Öffnung hat eine Toleranz von ±20 mm.
- für jeden Tortyp wird die Bezugsgröße des Antriebs (LT) angegeben.

3. Eingangs-/Ausgangsprofil – Baureihe Ditec PAM30

Schiebetor aus stranggepressten Profilen aus Aluminiumlegierung EN AW 6060 (UNI 9006/1) T5

- Querschnitt 30 mm

- geeignet für Antriebsanlagen der Firma DITEC, mit spezifischen Vorkehrungen, um jede Art von Sicherheit und Unfallverhütung zu gewährleisten

- Oberflächenbehandlung durch Einbrennlackierung (Polyesterpulver in den RAL-Farben - Marke Qualicoat) oder durch anodische Färbung (EURAS - Marke Qualanod).

Die Profilbaureihe ist mit Glashaltern um Glasvolumen mit einer Stärke von 8; 10; 22 mm unterzubringen, die für eine sichere Befestigung der Glasplatten und eine korrekte Einstellung in der Montagephase vorgerüstet sind. Das System ermöglicht zudem einen bequemen späteren Wartungseingriff, um ggf. abgenutzte oder durch äußere Einflüsse gebrochene Glasplatten auszutauschen. Das Profil ist mit speziellen Dichtungen aus EPDM für den hermetischen vertikalen Anschlag und mit Bürstendichtungen an den horizontalen zu öffnenden Begrenzungen ausgestattet, damit eine optimale Leistung in Bezug auf Wärme- und Schallschutzdichtung gewährleistet ist.

Die Profile können unter Beachtung der Spezifikationen in den technischen Handbüchern in den unterschiedlichsten kodierten Arten hergestellt werden, um die für die Installationsart am besten geeignete Auswahl treffen zu können.

Die Baureihe PAM30 besteht aus Profilen (Seitenpfosten und Querträger) mit robusten Sichtquerschnitten für die Erstellung aller Standardtypen und mit Oberlicht.



Ce symbole indique les instructions ou les notes concernant la sécurité pour laquelle il faut être particulièrement attentif.



Ce symbole indique les informations utiles pour le bon fonctionnement du produit.

1. Consignes générales de sécurité



Le présent manuel d'assemblage et d'installation s'adresse uniquement à un personnel qualifié.

Lire les instructions avec beaucoup d'attention avant d'installer le produit.

Une mauvaise installation peut être source de danger.

Pour toute réparation et tout remplacement des produits, seules des pièces de rechange d'origine devront être utilisées.



Les matériaux qui composent l'emballage (plastique, polystyrène, etc.) ne doivent pas être abandonnés dans la nature ni laissés à la portée des enfants car ils représentent des risques de danger.

Le système d'huisseries PAM30 est conforme aux exigences essentielles des normes suivantes :

Norme européenne EN 16005 - Blocs portes motorisés pour piétons – Sécurité d'utilisation

Norme DIN 18650-1 - Norme DIN 18650-2

Les dessins de tous les types standard sont disponibles en format graphique pour environnements CAO (dwg) et en format image (pdf) à l'adresse <http://www.ditecentrematic.com/download>.

2. Indications d'utilisation

Les essais effectués en laboratoire et sur place conduisent à une portée maximale du vantail de 120 kg.

Les formules adoptées dans les sections suivantes tiennent compte des critères standard :

- la baie de passage PLmax est considérée entre les montants verticaux des vantaux fixes et/ou du cadre. La baie de passage utile a une tolérance de ± 20 mm.

- la dimension de référence de l'automatisme est indiquée (LT) pour chaque type de porte.

3. Huisserie d'entrée/sortie – Série Ditec PAM30

Porte coulissante réalisée avec des profilés extrudés en alliage d'aluminium EN AW 6060 (UNI 9006/1) T5

- section de 30 mm

- indiquée pour installations automatisées DITEC, avec des solutions spécifiques visant à garantir la sécurité contre les accidents

- finition superficielle réalisée par traitement de peinture au four (poudres en polyester dans les couleurs RAL- marque Qualicoat) ou de coloration anodique (finitions EURAS - marque Qualanod).

La série de profilés est équipée pour loger des volumes de verre d'une épaisseur de 8 , 10 , 22 mm, prévus pour une fixation sûre des plaques de verre et pour un réglage correct en phase de mise en œuvre. Ce système permet également d'effectuer par la suite une intervention d'entretien pour d'éventuels remplacements de plaques détériorées ou cassées pour des causes accidentelles.

L'huissérie est fournie avec des joints spéciaux en EPDM pour la butée vertical hermétique, munie de joints à brosse sur les périmètres horizontaux ouvrants, de manière à garantir une prestation optimale d'étanchéité thermo-acoustique du système.

Les huisseries peuvent être réalisées dans les types codés les plus divers afin de garantir un choix apte au type d'installation, en se conformant aux spécifications indiquées dans les Manuels Techniques.

La série PAM30 est composée de profilés (montants et traverses) de sections robustes, pour la réalisation de tous les types Standard et avec Imposte.



Este símbolo indica instrucciones o notas relativas a la seguridad a las que prestar una atención especial.



Este símbolo indica informaciones útiles para el funcionamiento correcto del producto.

1. Advertencias generales de seguridad



Este manual de montaje e instalación está exclusivamente dirigido a personal cualificado.
Lea detenidamente las instrucciones antes de comenzar la instalación del producto.
Una instalación incorrecta puede ser causa de peligro.
Utilice sólo recambios originales para la reparación o la sustitución de los productos.



Los materiales de embalaje (plástico, poliestireno, etc.) no deben arrojarse en el medio ambiente y deben mantenerse fuera del alcance de los niños al ser una posible fuente de peligro.

El sistema de cierres PAM30 es conforme a los requisitos esenciales de las siguientes Normas:

Norma Europea EN 16005 - La seguridad en el uso de las puertas peatonales
Norma DIN 18650-1 - Norma DIN 18650-2

Los planos de todos los tipos estándar están disponibles en formato gráfico para entornos CAD (dwg) y en formato de imagen (pdf) en la dirección <http://www.ditecentrematic.com/download>.

2. Instrucciones de uso

Las pruebas efectuadas en el laboratorio y en el lugar de funcionamiento indican una capacidad máxima de la hoja de 120 kg.

En las secciones siguientes, las fórmulas adoptadas tienen en cuenta los siguientes criterios estándar:

- el hueco de paso PL_{máx} se considera entre los montantes verticales de las hojas fijas y/o del marco. El hueco de paso útil tiene una tolerancia de ± 20 mm.
- para cada tipo de puerta, se indica la dimensión de referencia del automatismo (LT).

3. Cierre de entrada/salida – Serie Ditec PAM30

Puerta corredera realizada con perfiles extruidos de aleación de aluminio EN AW 6060 (UNI 9006/1) T5

- sección de 30 mm

- adecuada para instalaciones automatizadas DITEC, con soluciones específicas capaces de garantizar cualquier dispositivo de seguridad de prevención de accidentes

- acabado superficial realizado con tratamiento de pintura en horno (polvos de poliéster en los colores RAL- marca Qualicoat) o de coloración anódica (acabados EURAS - marca Qualanod).

La serie de perfiles está equipada para alojar volúmenes de cristal con un espesor de 8, 10, 22 mm, preparados para una fijación segura de las placas de cristal y para una regulación correcta durante la instalación. El sistema permite además una intervención de mantenimiento posterior sencilla para eventuales sustituciones de cristales deteriorados o rotos por causas accidentales.

El cierre está equipado con juntas especiales de EPDM para el tope vertical hermético, dotado de juntas de cepillo en los perímetros horizontales abribles, de modo que garantiza unas óptimas prestaciones de estanqueidad termoacústica del sistema.

Cierres realizables en los más diversos tipos codificados para permitir la elección idónea para el tipo de instalación, ateniéndose a las especificaciones indicadas en los Manuales Técnicos.

La serie PAM30 se compone de perfiles (montantes y traveseros) de robustas secciones, para la realización de todos los tipos estándar y con montante.



Êsse símbolo indica instruções ou notas relativas à segurança que requerem uma atenção particular.



Êsse símbolo indica informações úteis para o correcto funcionamento do produto.

1. Advertências gerais para a segurança



O presente manual de montagem e instalação é dirigido exclusivamente a profissionais especializados.

Leia atentamente as instruções antes de iniciar a instalação do produto.

Uma instalação errada pode ser fonte de perigo.

Para a eventual reparação ou a substituição dos produtos deverão ser utilizadas exclusivamente peças de reposição genuínas.



Os materiais da embalagem (plástico, polistireno, etc.) não devem ser abandonados no ambiente e não devem ser deixados ao alcance de crianças, pois são potenciais fontes de perigo.

O sistema de ferragens PAM30 está em conformidade com os requisitos essenciais das seguintes Normas:

Norma Europeia EN 16005 - A segurança em uso das portas pedonais

Norma DIN 18650-1 - Norma DIN 18650-2

O projeto de todos os tipos padrão está disponível em formato gráfico para ambientes CAD (dwg) e em formato de imagem (pdf) no endereço <http://www.ditecentrematic.com/download>.

2. Indicações de uso

Os testes realizados em laboratório e no local de trabalho levaram a uma capacidade máxima da portinhola de 120 kg.

Nas secções abaixo, as fórmulas tomam em conta os seguintes critérios padrão:

- o vão de passagem PL_{max} deve ser considerado entre os montantes verticais das portinholas fixas e/ou do caixilho. O vão útil de passagem tem uma tolerância de ±20 mm.

- para cada tipo de porta é indicada a dimensão de referência do automatismo (LT).

3. Ferragem de entrada/saída – Série Ditec PAM30

Porta de correr realizada com perfis extrudados em liga de alumínio EN AW 6060 (UNI 9006/1) T5

- secção de 30 mm

- adequada para instalações automatizadas DITEC, com medidas específicas que garantem a prevenção de acidentes

- acabamento superficial realizado com tratamento de pintura à forno (pó de poliéster nas cores RAL- marca Qualicoat) ou de coloração anódica (acabamentos EURAS - marca Qualanod).

A série de perfis está equipada para alojar volumes de vidros com uma espessura de 8, 10, 22 mm, predispostos para uma fixação segura das placas de vidro e para uma regulação correcta em fase de instalação. O sistema permite, além disso, uma fácil intervenção posterior de manutenção para eventuais substituições de placas deterioradas ou danificadas por causas acidentais.

A ferragem é equipada com vedações especiais em EPDM para o batente vertical hermético, equipado com vedações de escova nos perímetros horizontais abríveis, para garantir um desempenho ideal de vedação termoacústica do sistema.

Ferragens realizáveis nos mais variados tipos e codificadas para permitir a escolha apropriada ao tipo de instalação, atendo-se às especificações indicadas nos Manuais Técnicos.

A série PAM30 é composta de perfis (montantes e transversais) de fortes secções, para a realização de todos os tipos Padrão e com Bandeira.

4. Legend

	EN	IT	DE	FR	ES	PT
M	Moving door wing	Anta mobile	Fahrflügel	Vantail mobile	Hoja móvil	Portinhola móvel
F	Fixed door wing	Anta fissa	Seitenteil	Vantail fixe	Hoja fija	Portinhola fixa
T	Beam	Trave	Kämpferprofil	Montant	Viga	Trave
C	Frame	Cornice	Rahmen	Cadre	Marco	Caixilho
S	Overlight	Sopraluce	Oberlicht	Imposte	Montante	Bandeira
L	Overall wall opening width	Larghezza utile vano muro	Nutzbare Breite der Wandöffnung	Largeur utile de la baie dans le mur	Anchura útil espacio pared	Largura útil do vão da parede
PL	Passage opening width	Larghezza vano passaggio	Breite des Platzbedarfs für die Öffnung	Largeur de la baie de passage	Anchura hueco de paso	Largura do vão de passagem
LT	Automation length	Lunghezza automazione	Länge des Antriebs	Longueur de l'automatisme	Longitud automatismo	Comprimento do automatismo
LF	Fixed door wing width	Larghezza anta fissa	Breite des festen Flügels	Largeur du vantail fixe	Anchura hoja fija	Largura da portinhola fixa
LVF	Fixed door wing glass width	Larghezza vetro anta fissa	Breite der Scheibe des festen Flügels	Largeur de la vitre du vantail fixe	Anchura cristal hoja fija	Largura do vidro da portinhola fixa
LM	Moving door wing width	Larghezza anta mobile	Breite des beweglichen Flügels	Largeur du vantail mobile	Anchura hoja móvil	Largura da portinhola móvel
LVM	Moving door wing glass width	Larghezza vetro anta mobile	Breite der Scheibe des beweglichen Flügels	Largeur de la vitre du vantail mobile	Anchura cristal hoja móvil	Largura do vidro da portinhola móvel
H	Effective wall opening height	Altezza utile vano muro	Nutzbare Höhe der Wandöffnung	Hauteur utile de la baie dans le mur	Altura útil hueco pared	Altura útil do vão da parede
PH	Passage opening height	Altezza vano passaggio	Höhe des Platzbedarfs für die Öffnung	Hauteur de la baie de passage	Altura hueco de paso	Altura do vão de passagem
H1	Effective height under beam	Altezza utile sotto trave	Nutzbare Höhe unter dem Kämpferprofil	Hauteur utile sous montant	Altura útil bajo la viga	Altura útil sob a trave
HF	Fixed door wing height	Altezza anta fissa	Höhe des Seitenteils	Hauteur du vantail fixe	Altura hoja fija	Altura da portinhola fixa
HVF	Fixed door wing glass height	Altezza vetro anta fissa	Glashöhe des Seitenteils	Hauteur de la vitre du vantail fixe	Altura cristal hoja fija	Altura do vidro da portinhola fixa
HM	Moving door wing height	Altezza anta mobile	Höhe des Fahrflügels	Hauteur du vantail mobile	Altura hoja móvil	Altura da portinhola móvel
HVM	Moving door wing glass height	Altezza vetro anta mobile	Glashöhe des Fahrflügels	Hauteur de la vitre du vantail mobile	Altura cristal hoja móvil	Altura do vidro da portinhola móvel
OL	Overlight width	Larghezza sopra luce	Breite des Oberlichts	Largeur de l'imposte	Anchura montante	Largura da bandeira
OH	Overlight height	Altezza sopra luce	Höhe des Oberlichts	Hauteur de l'imposte	Altura montante	Altura da bandeira
LVO	Overlight glass width	Larghezza vetro sopra luce	Breite der Scheibe des Oberlichts	Largeur de la vitre de l'imposte	Anchura cristal montante	Largura do vidro da bandeira
HVO	Overlight glass height	Altezza vetro sopra luce	Höhe der Scheibe des Oberlichts	Hauteur de la vitre de l'imposte	Altura cristal montante	Altura do vidro da bandeira

NOTE 1: in compliance with the EN 16005 Standard, transparent glass panels must be marked. The application of stickers complies with the provisions of the Standard regarding accident prevention.

5. Profiles shape

T01
Scale 1:1

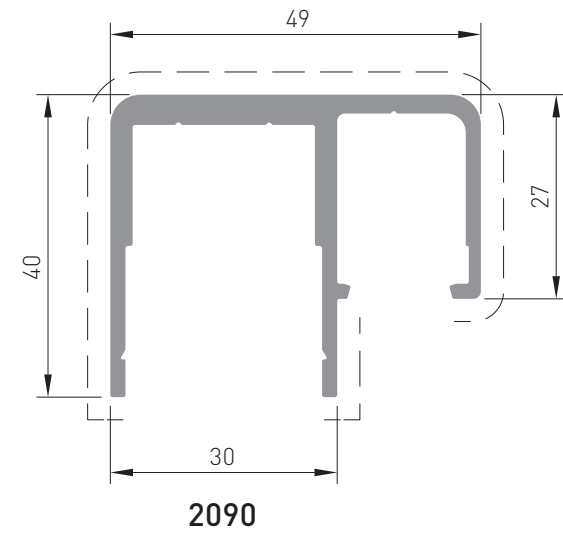
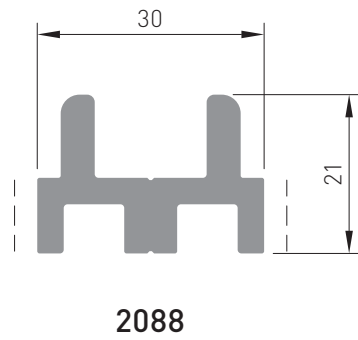
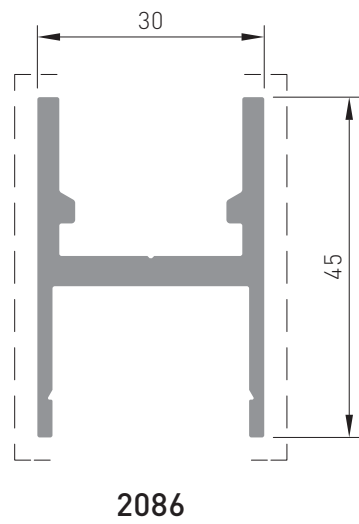
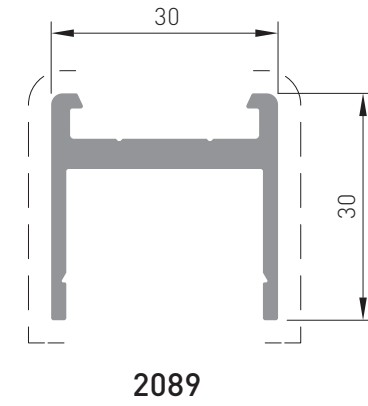
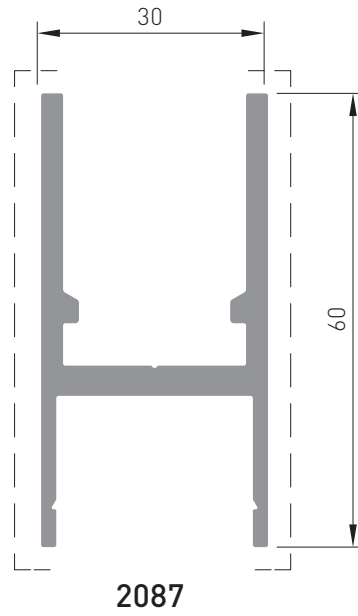
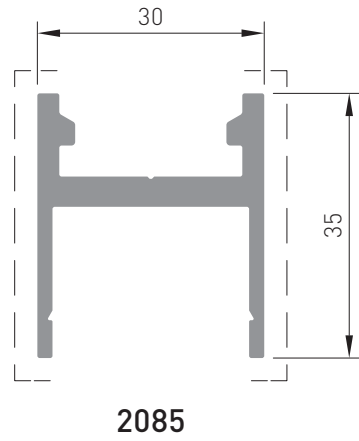

--- = Visible surface

5. Profiles shape

T02

Scale 1:1

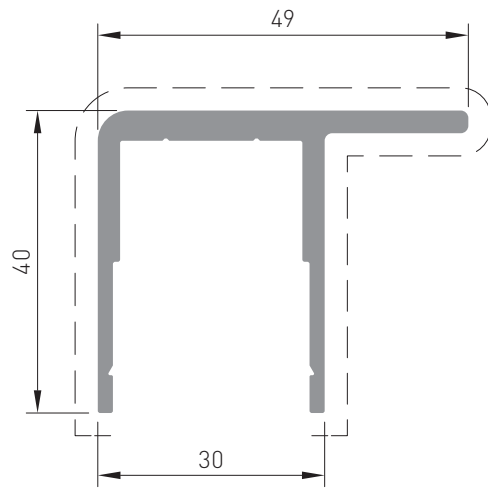

2091

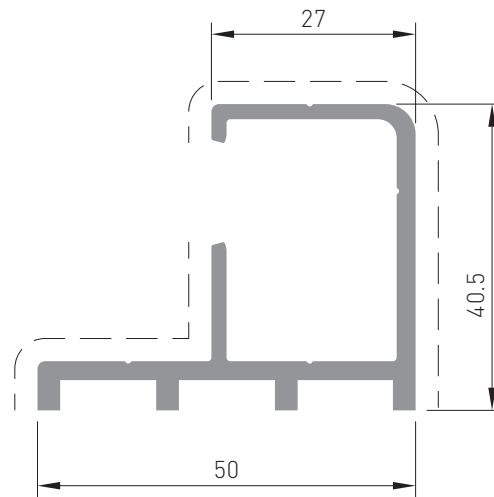

2092

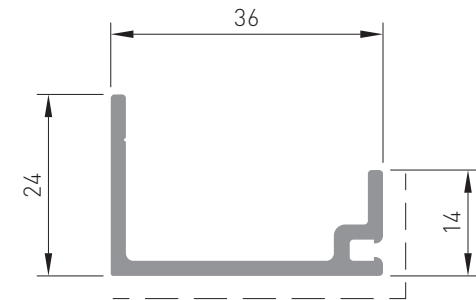

2226

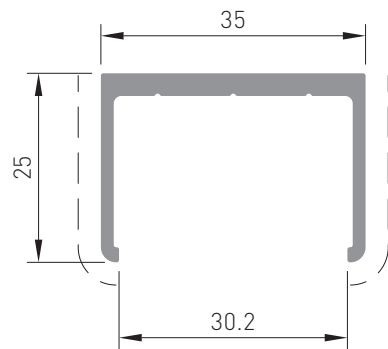

2093

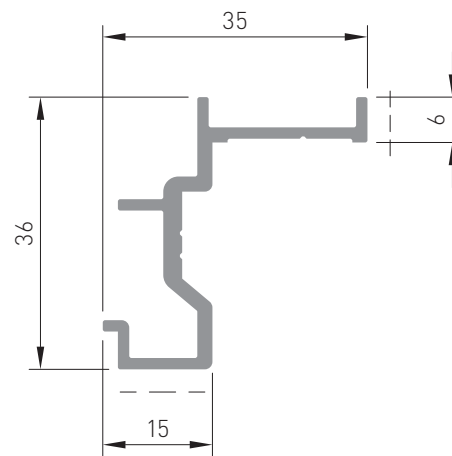

2458

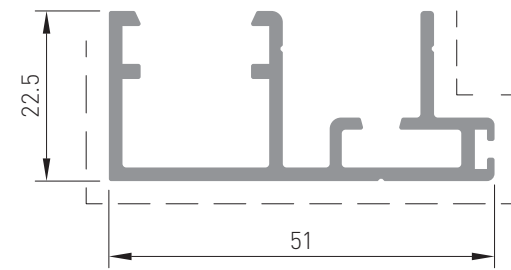

4073

----- = Visible surface

5. Profiles shape

T03
Scale 1:1

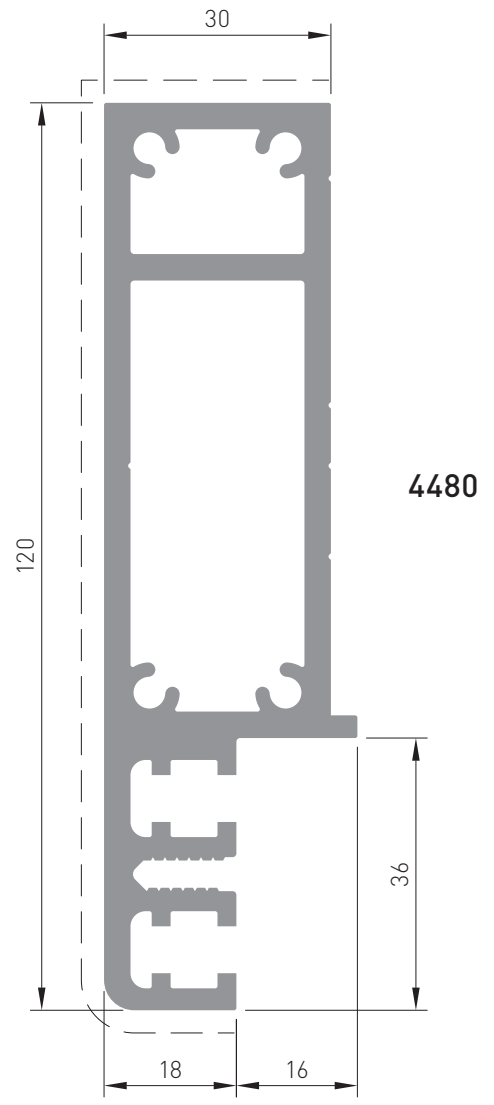
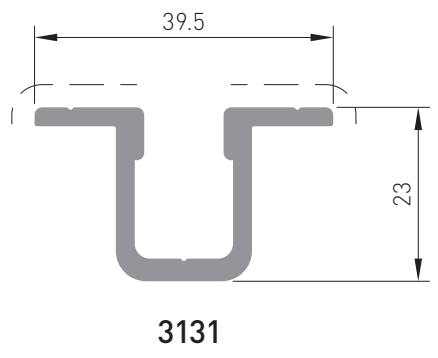
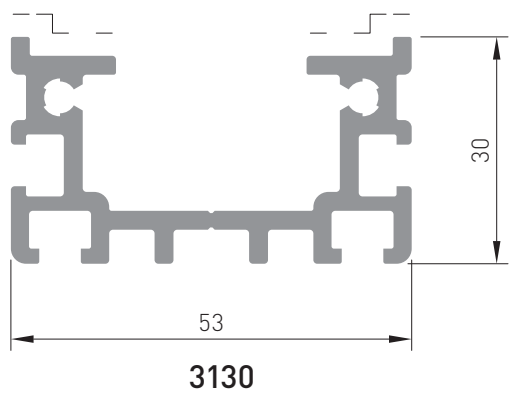
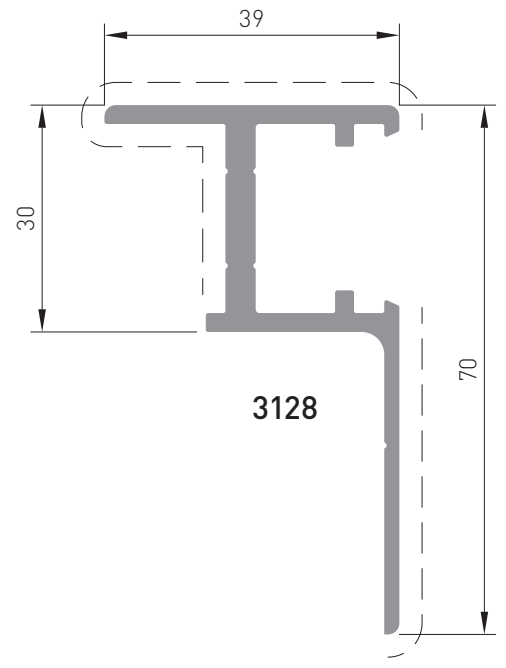
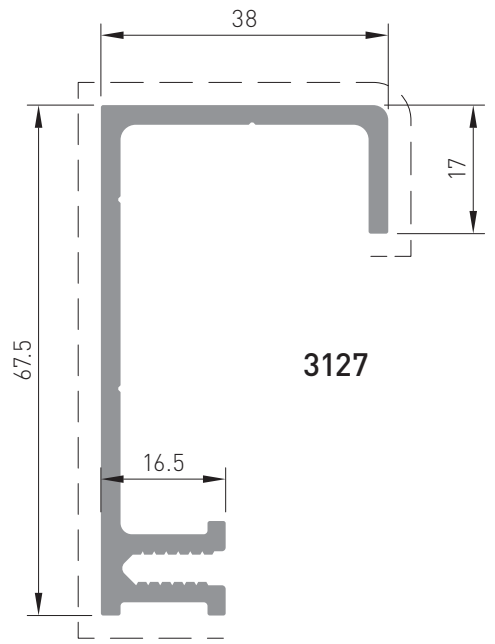

----- = Visible surface

5. Profiles shape

T04
Scale 1:1

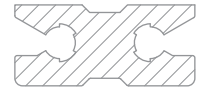
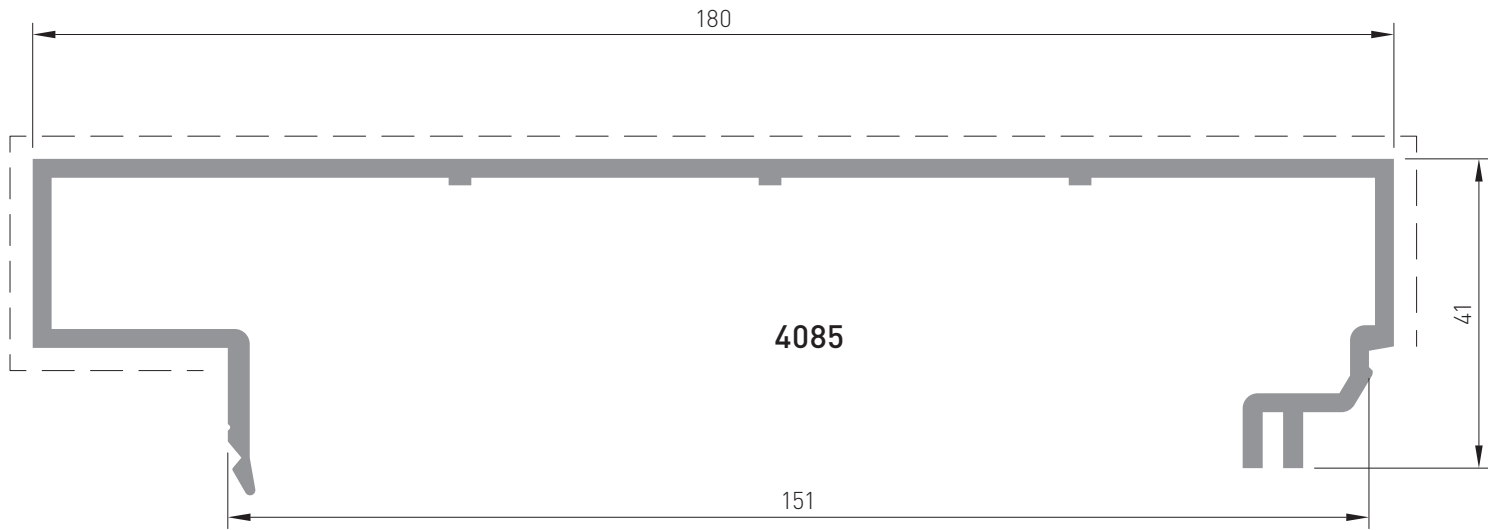

2094

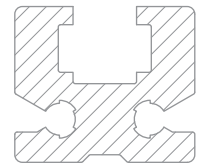

2095

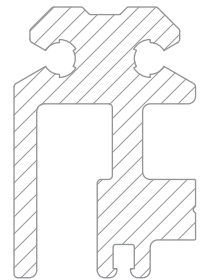
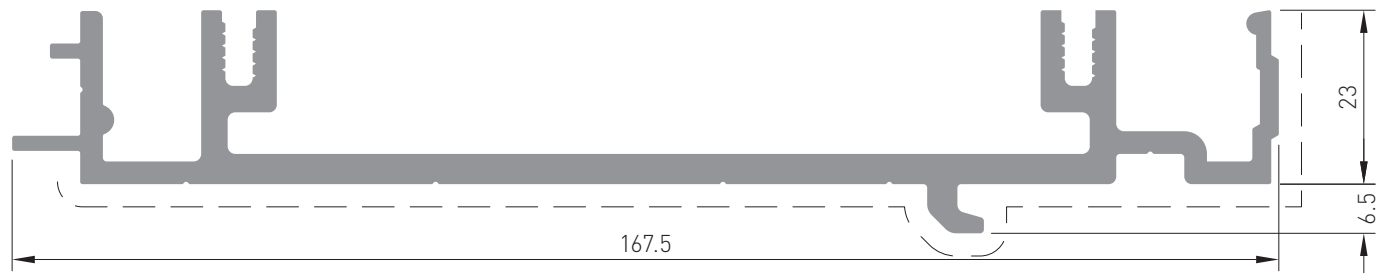

2096

----- = Visible surface

5. Profiles shape / Gaskets shape

T05
Scale 1:1

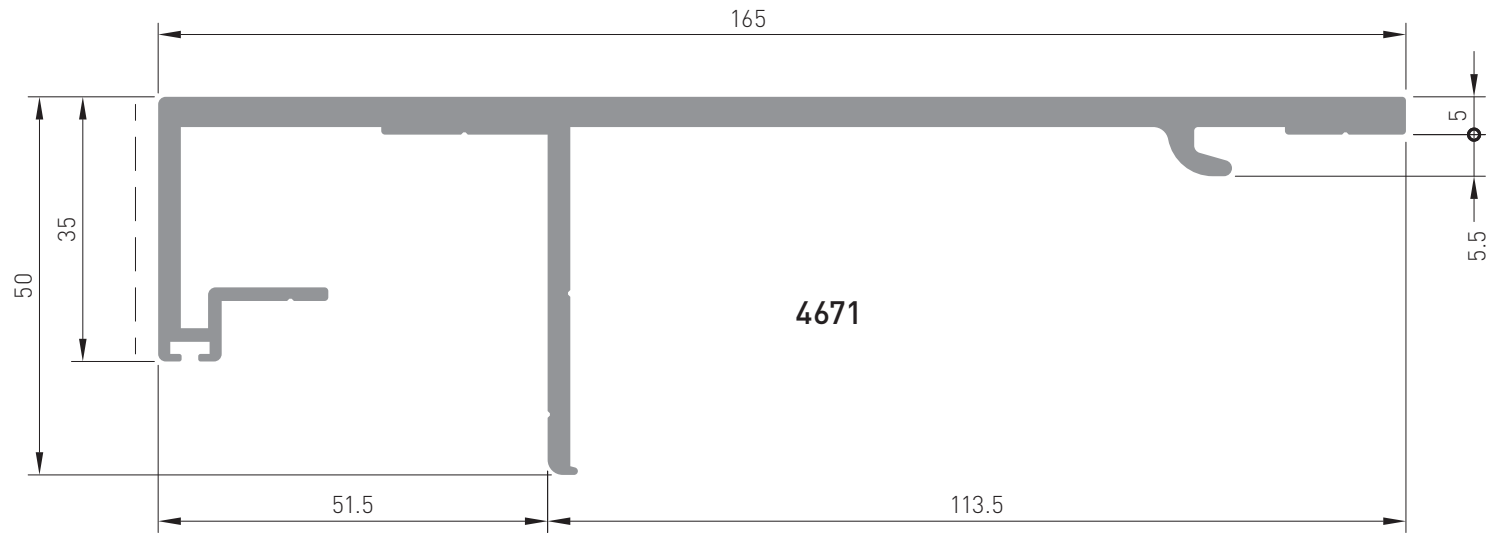

--- = Visible surface

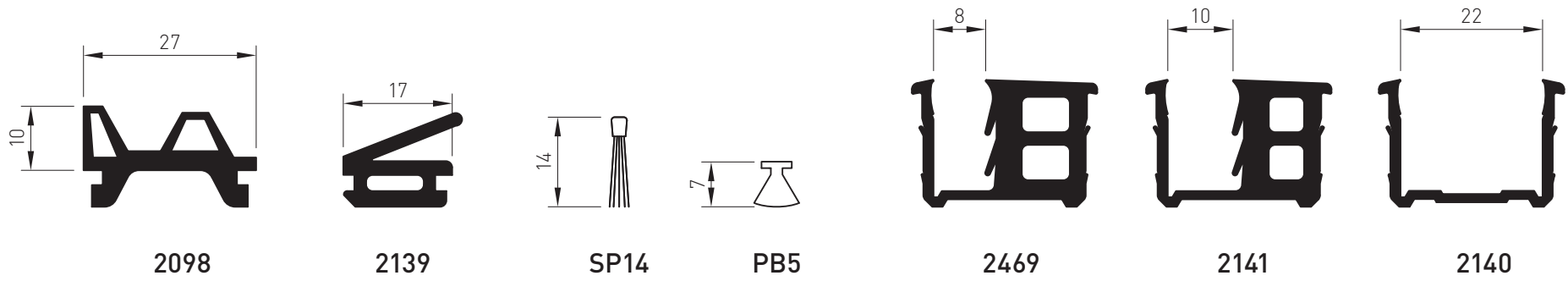

6. Accessories

T06

KAM30

n° 4 Clips



n° 2 TC 4.8 x 9.5



n° 1 Floor Guide



n° 8 TPS 4.8 x 32

KAF30

n° 8 TPS 4.8 x 32



n° 1 Fixing Bracket



n° 2 Fixing Brackets



n° 3 TC 4.8 x 13

KTT23

n° 4 TC 3.9 x 13



Couple of Beam Endcups



KT4063



n° 2 Beam Older



K2097L

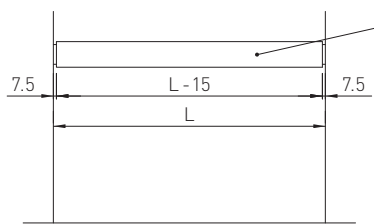
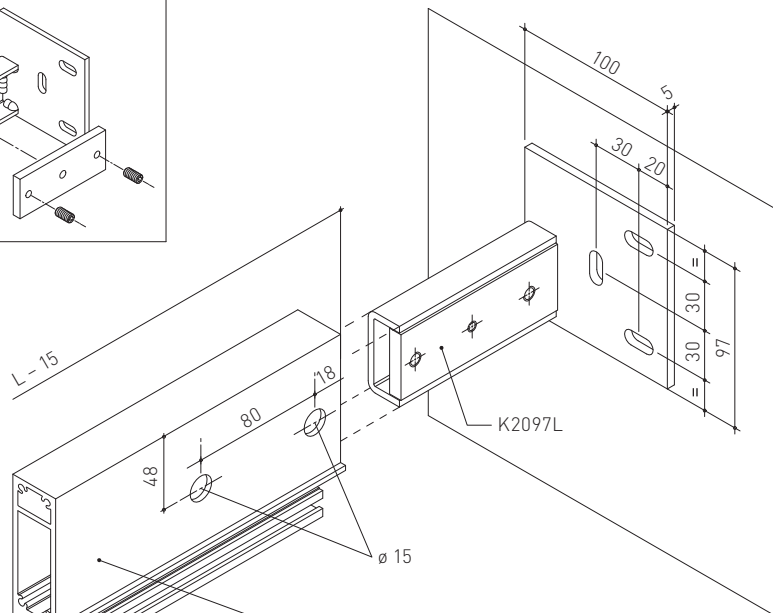
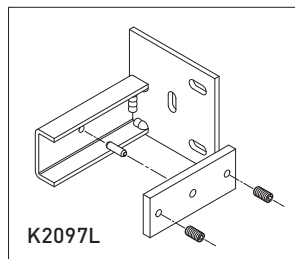

2097

KGI

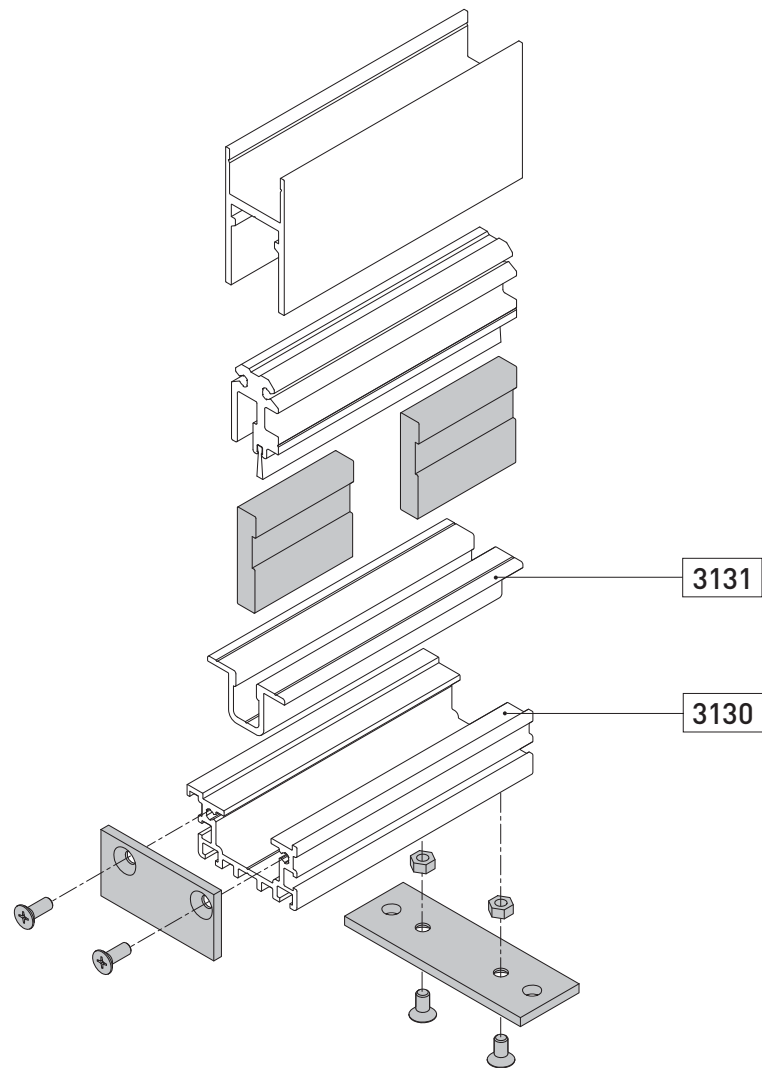

7. Glass thickness

T09

Scale 1:1

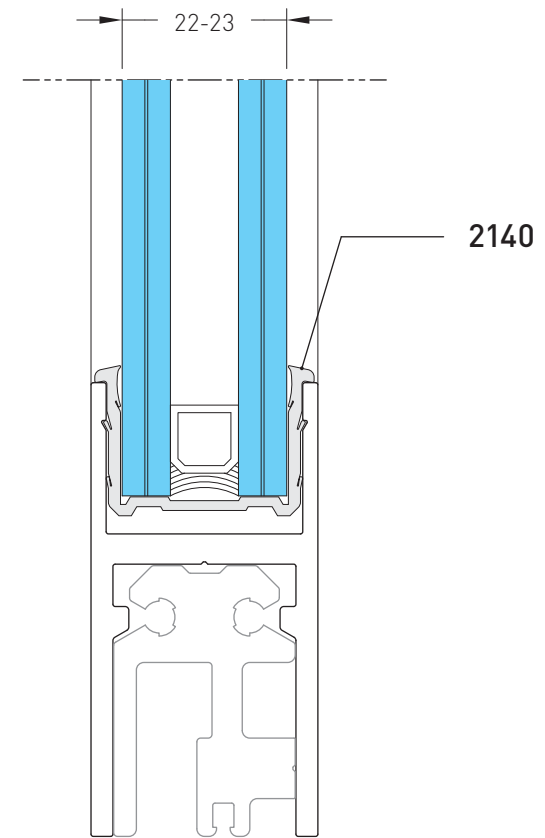
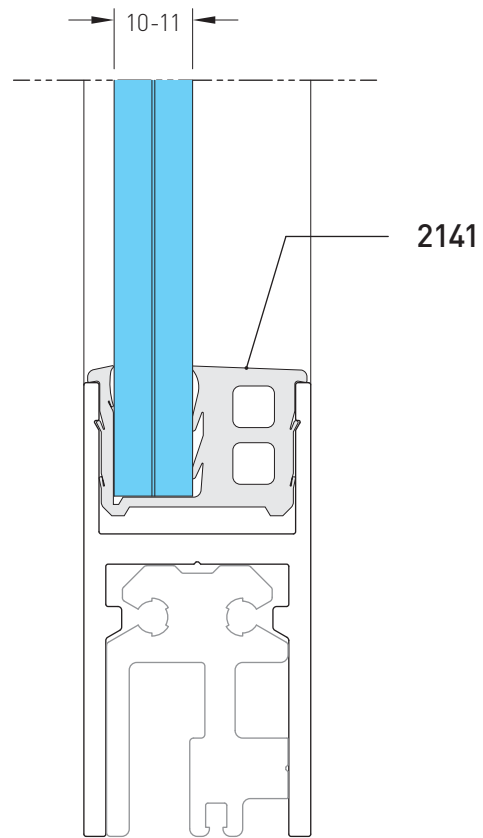
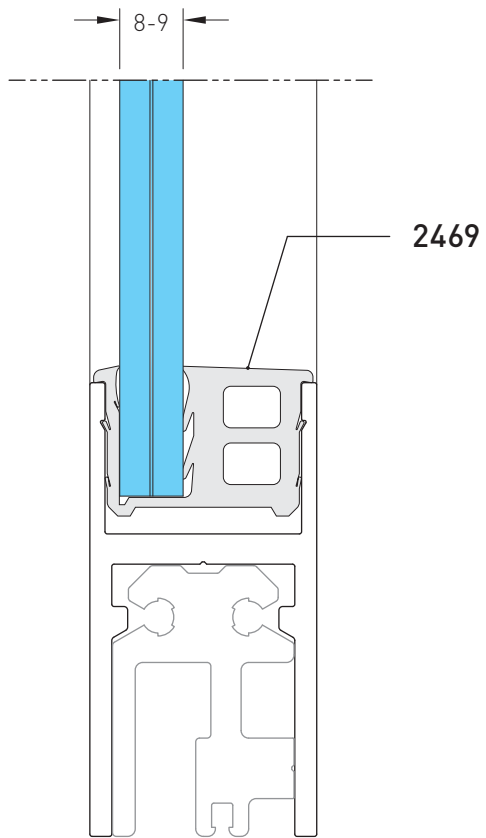

8. Applications

T10

Scale 1:2

EN The PAM30 door frames allow frames to be motorised with Ditec VALOR and REX S automations.

i VALOR and REXS automations are not included in the configuration.

The examples of vertical and horizontal sections that follow, show (for illustrative purposes only) the VALOR automations.

IT I serramenti PAM30 consentono la motorizzazione degli infissi con automazioni tipo Ditec VALOR e REXS.

i Le automazioni VALOR e REXS sono escluse dalla configurazione.

Gli esempi di sezioni verticali e orizzontali che seguiranno rappresentano (a titolo puramente indicativo) le automazioni VALOR.

DE Die Profile PAM30 ermöglichen die Motorisierung der Torprofile mit Antrieben des Typs Ditec VALOR und REXS.

i Die Antriebe VALOR und REX S sind nicht in der Konfiguration enthalten.

Die nachfolgenden Beispiele der Vertikal- und Horizontalschnitte stellen (rein informativ) die VALOR-Antriebe dar.

FR Les huisseries PAM30 permettent la motorisation des portails à automatismes de type Ditec VALOR et REXS.

i Les automatismes VALOR et REXS sont exclus de la configuration.

Les exemples suivants de sections verticales et horizontales représentent (à titre purement indicatif) les automatismes VALOR.

ES Los cierres PAM30 permiten la motorización de marcos con automatismos tipo Ditec VALOR y REXS.

i Los automatismos VALOR y REXS no se incluyen en la configuración.

Los ejemplos de secciones verticales y horizontales siguientes representan (a título puramente indicativo) los automatismos VALOR.

PT As ferragens PAM30 permitem a motorização dos infixos com automatismos do tipo Ditec VALOR e REXS.

i Os automatismos VALOR e REXS estão excluídos da configuração.

Os exemplos de secções verticais e horizontais que seguem representam (a título puramente indicativo) os automatismos VALOR.

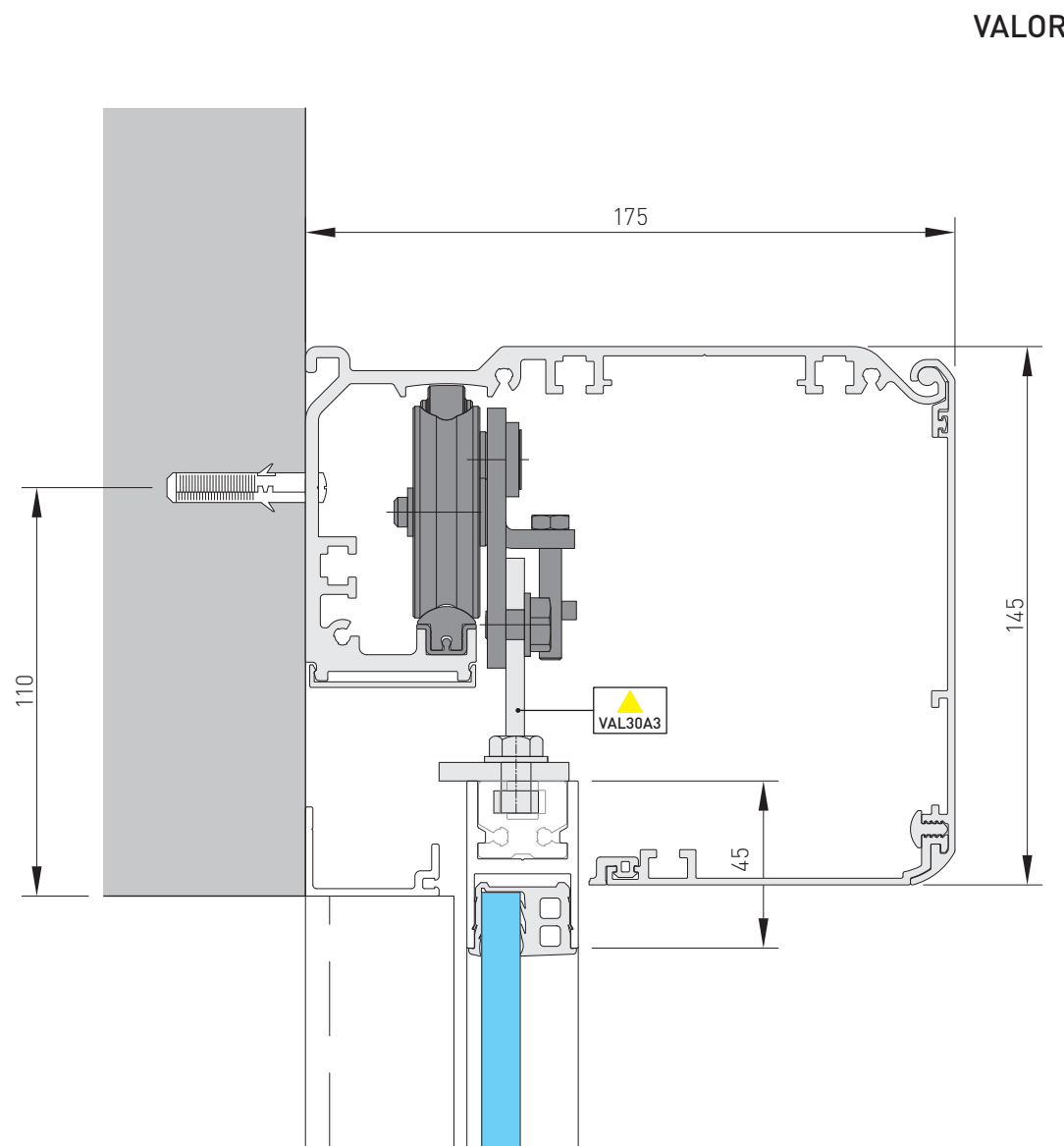

8. Applications

T11
Scale 1:2

VALOR + V4671

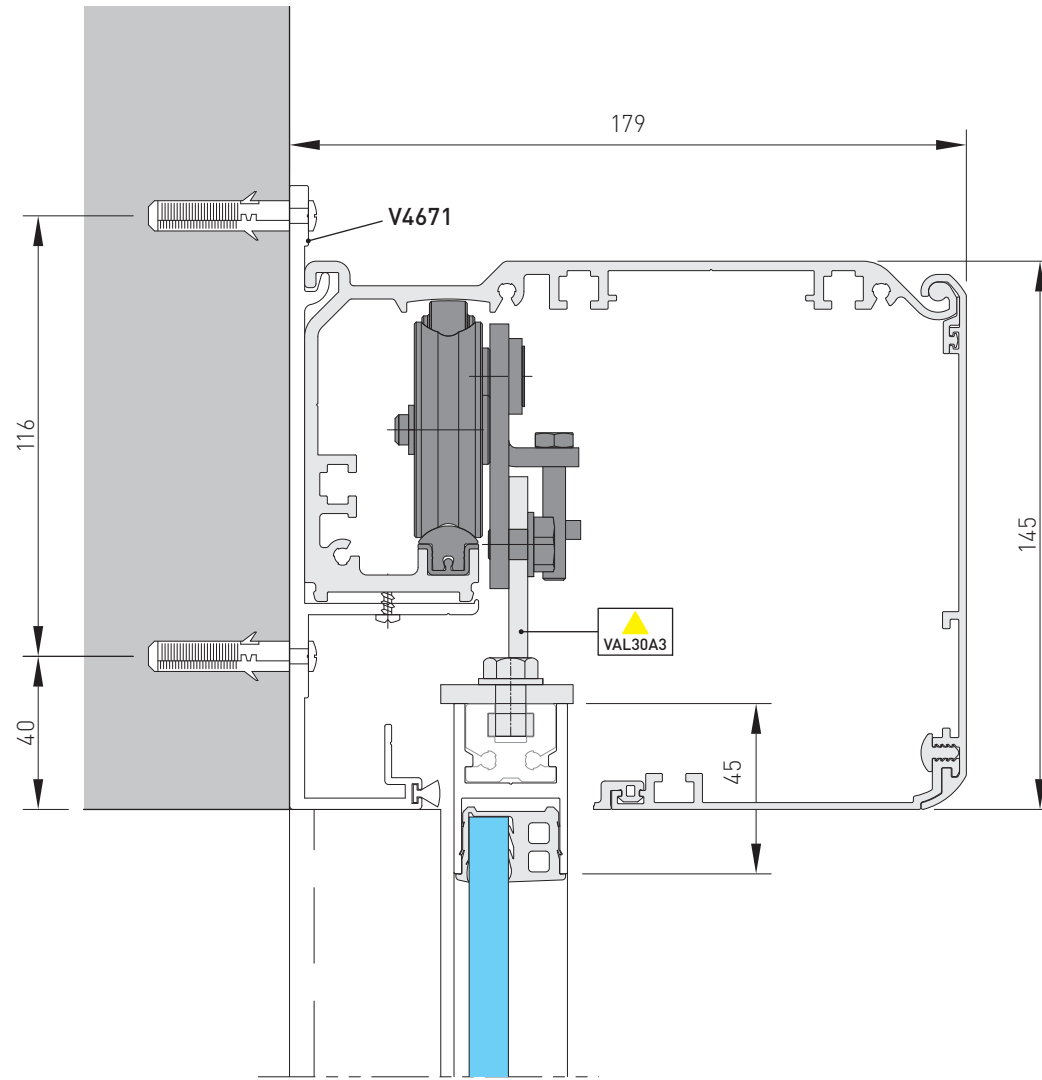

8. Applications

T12

Scale 1:2

VALOR + V4063

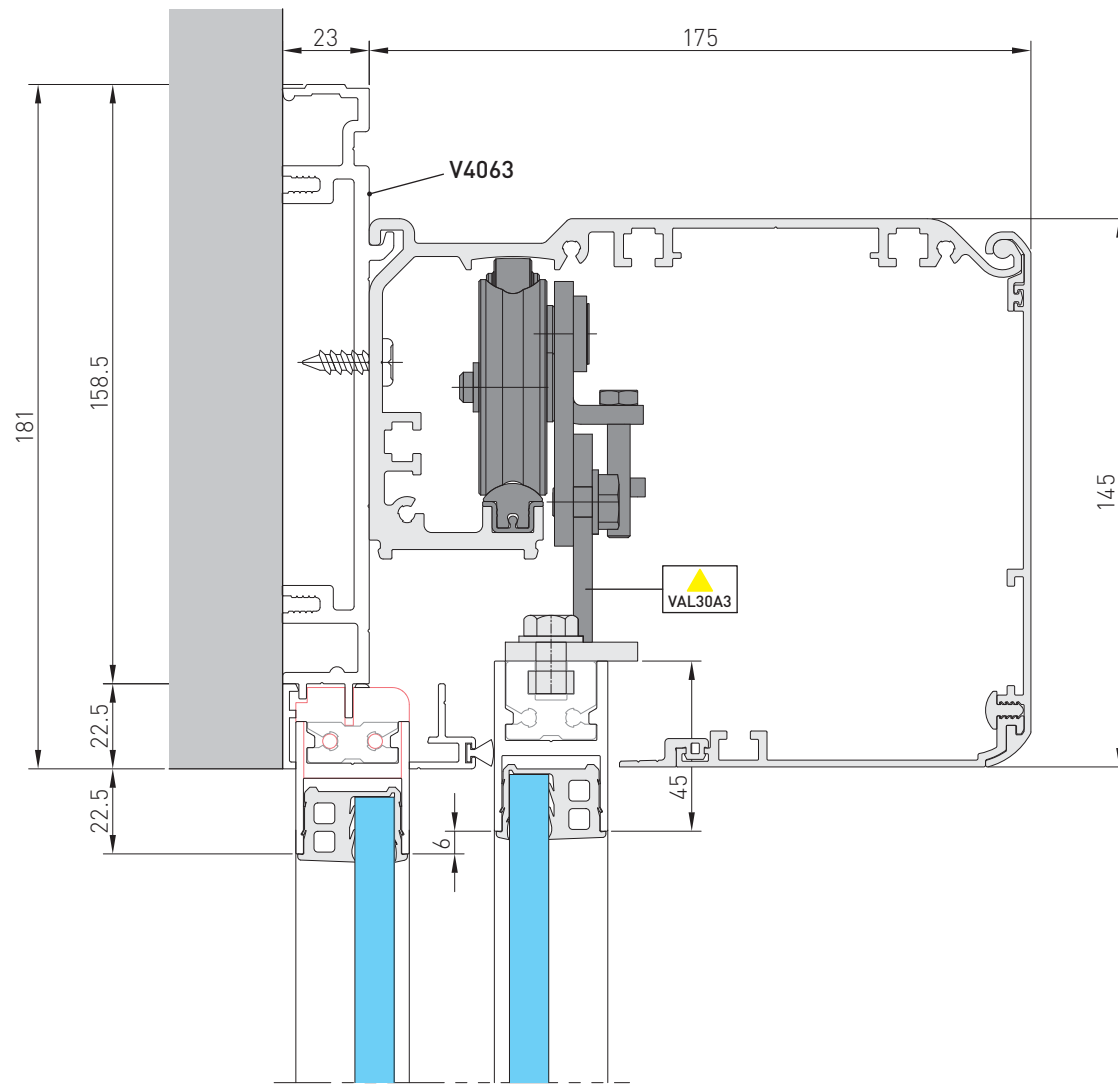

8. Applications

T13
Scale 1:2

REX-S

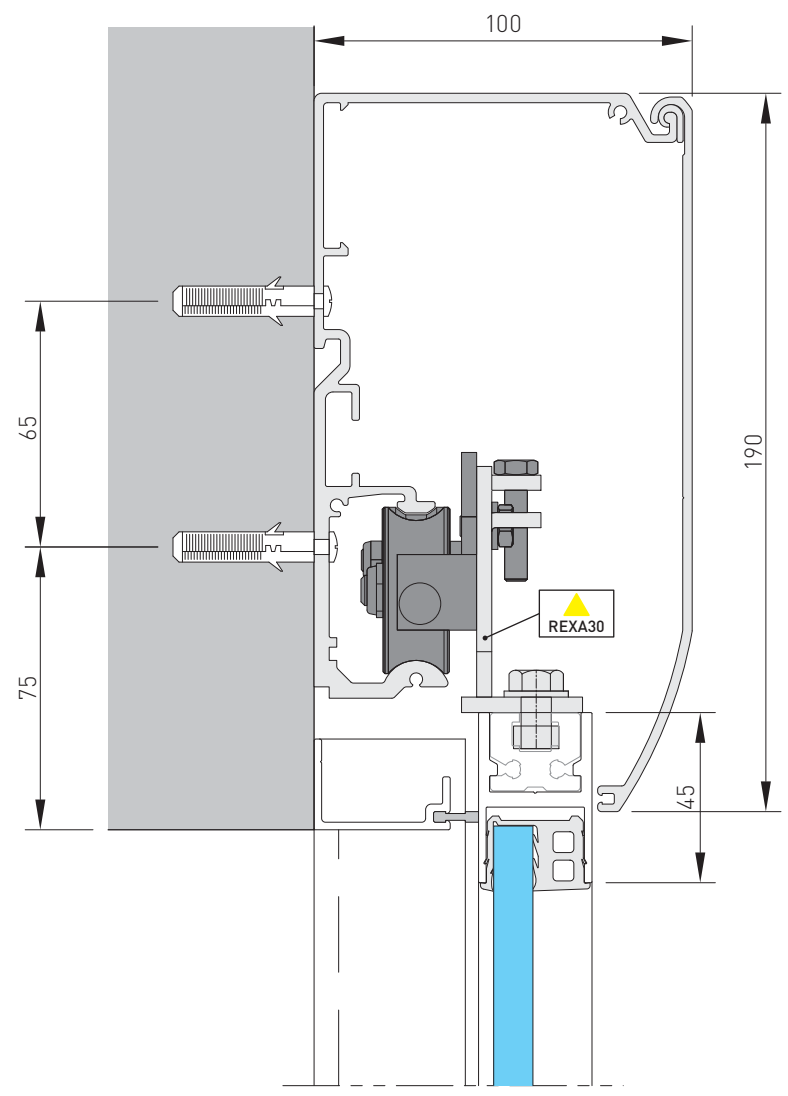

9. Vertical and horizontal section of 1 moving door wing with right-hand opening (standard version)

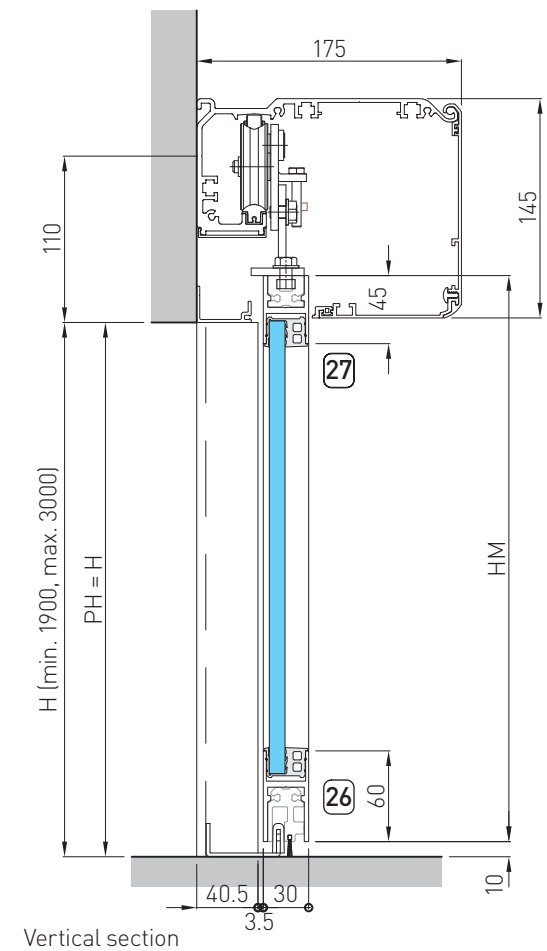
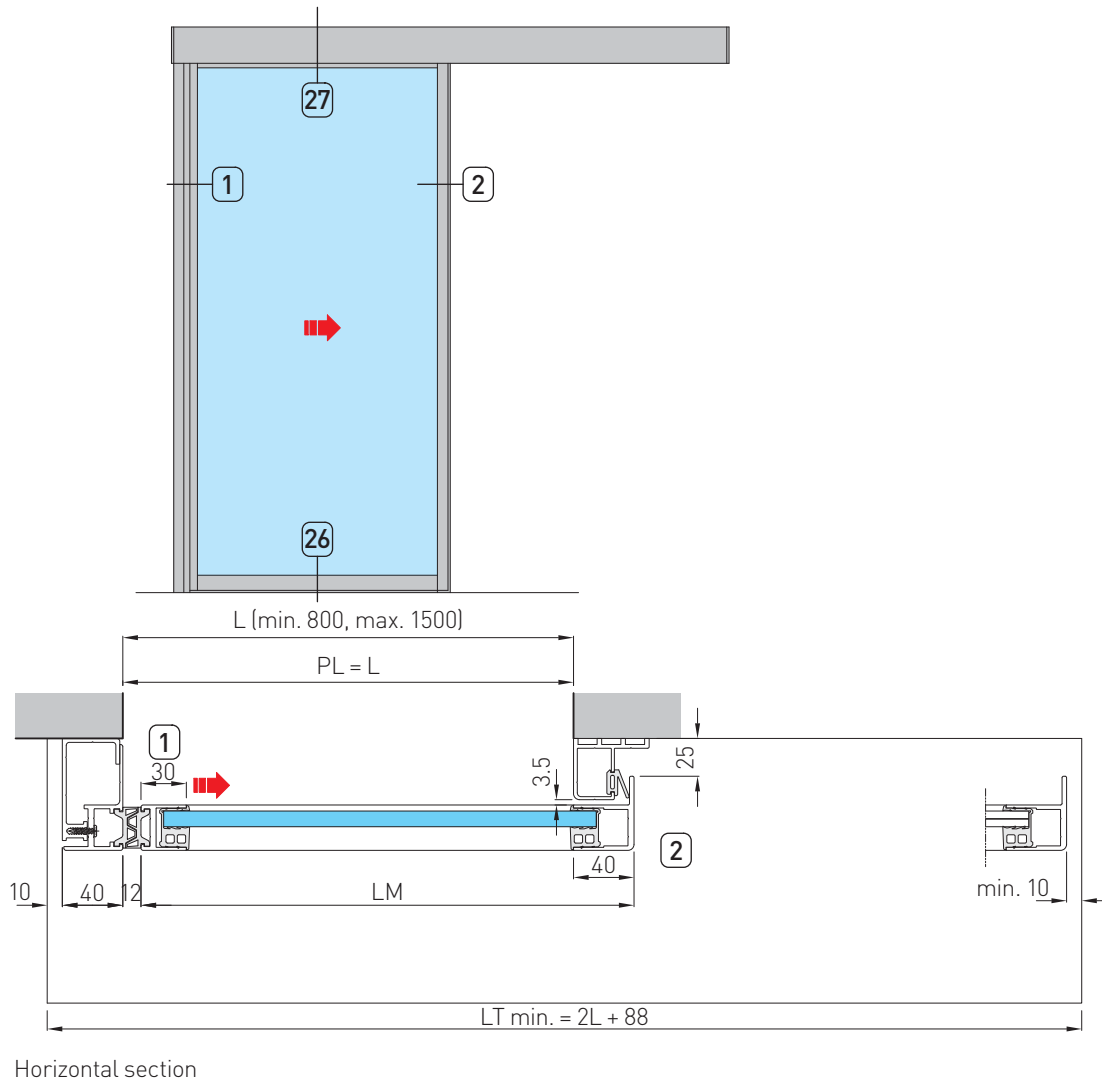

11. Vertical and horizontal section of 1 moving door wing with left-hand opening (standard version)

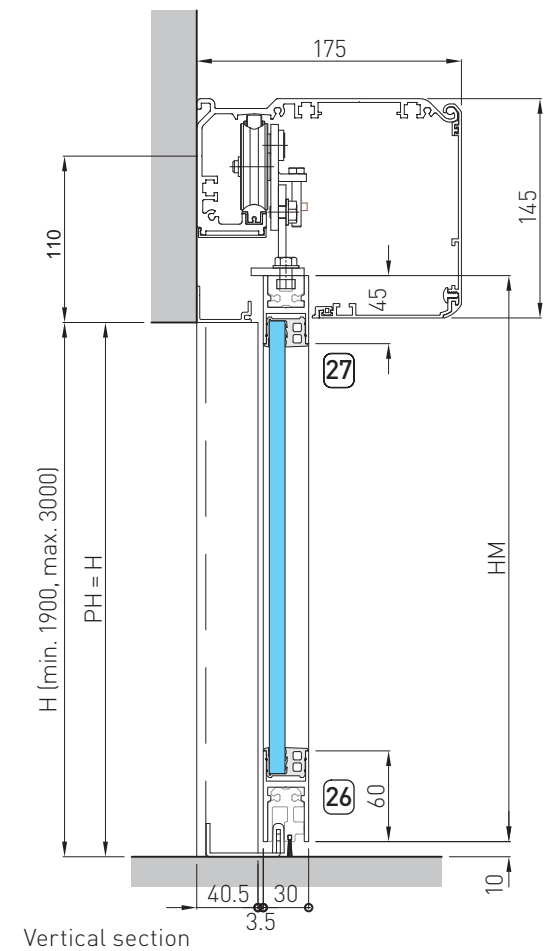
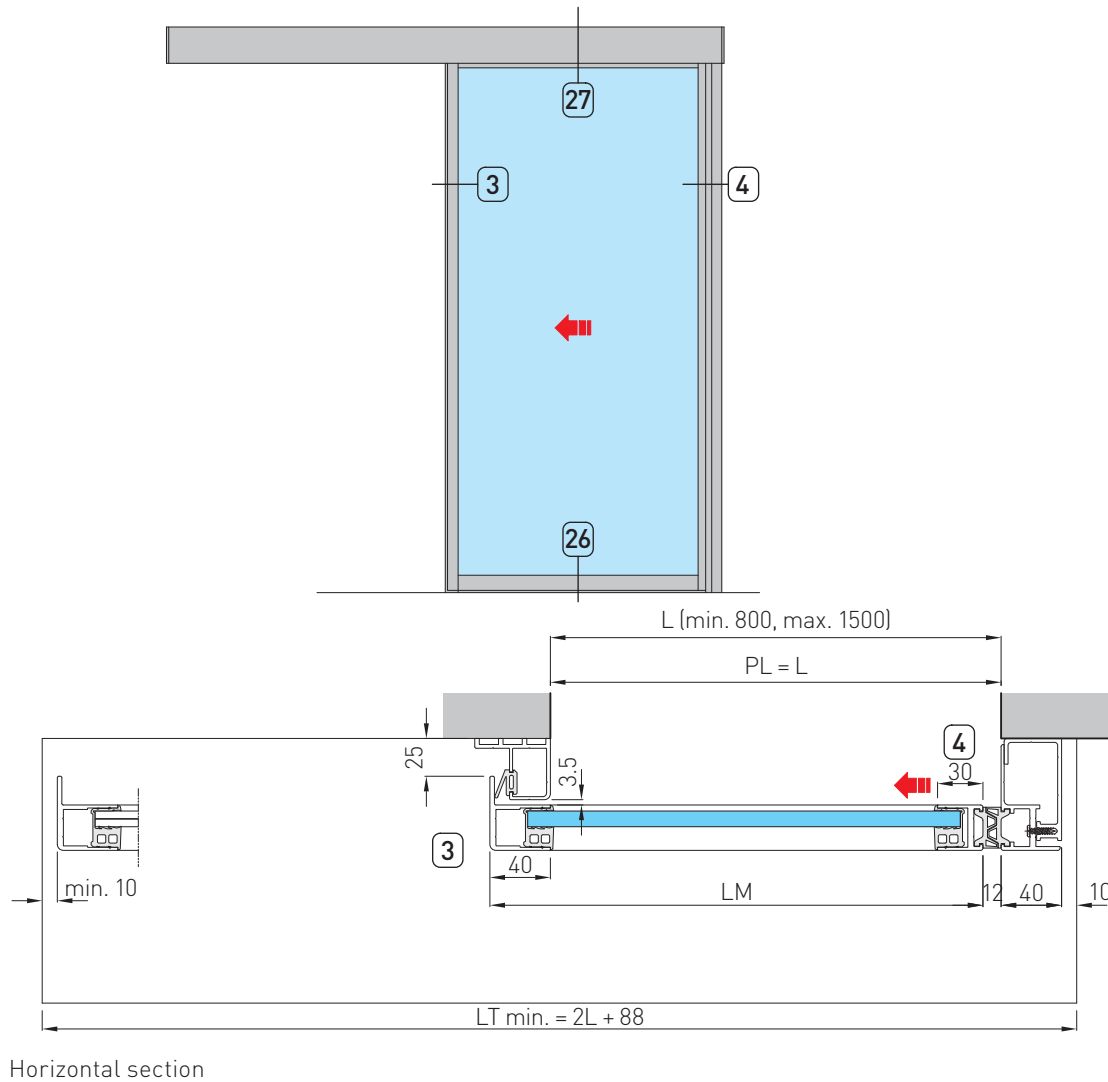

12. Vertical and horizontal section of 1 moving door wing with left-hand opening (standard version)

T17N

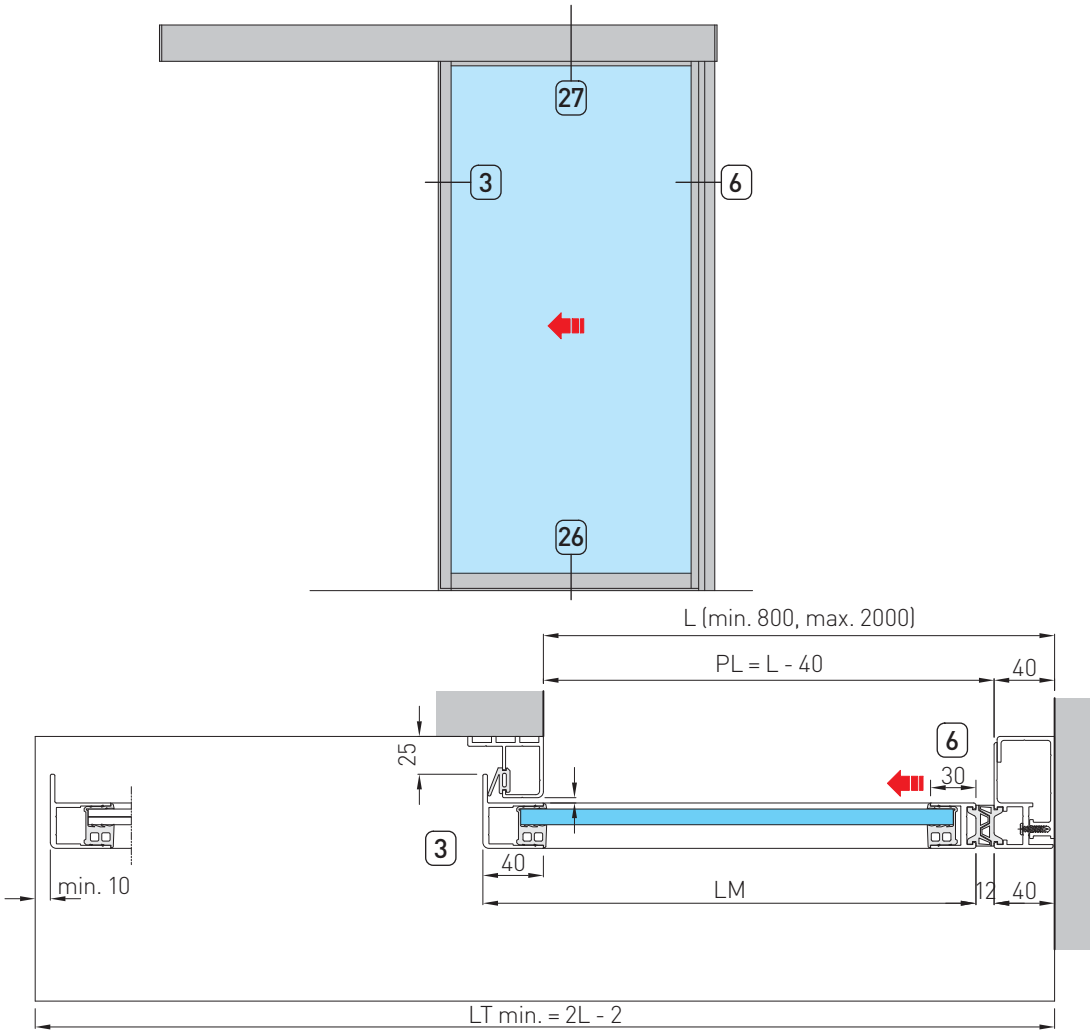

Horizontal section

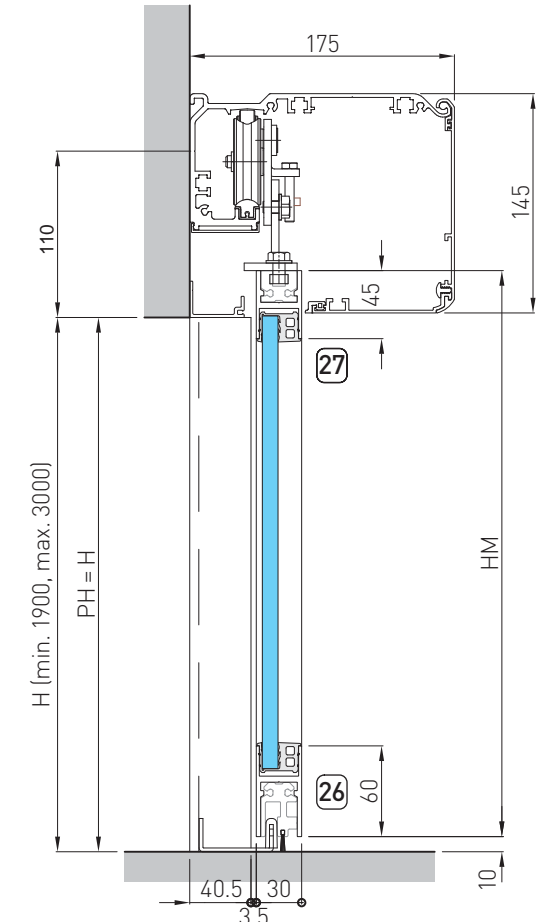

Vertical section

13. Vertical and horizontal section of 1 moving door wing with right-hand opening (french version)

Valor only (not Rex-S)

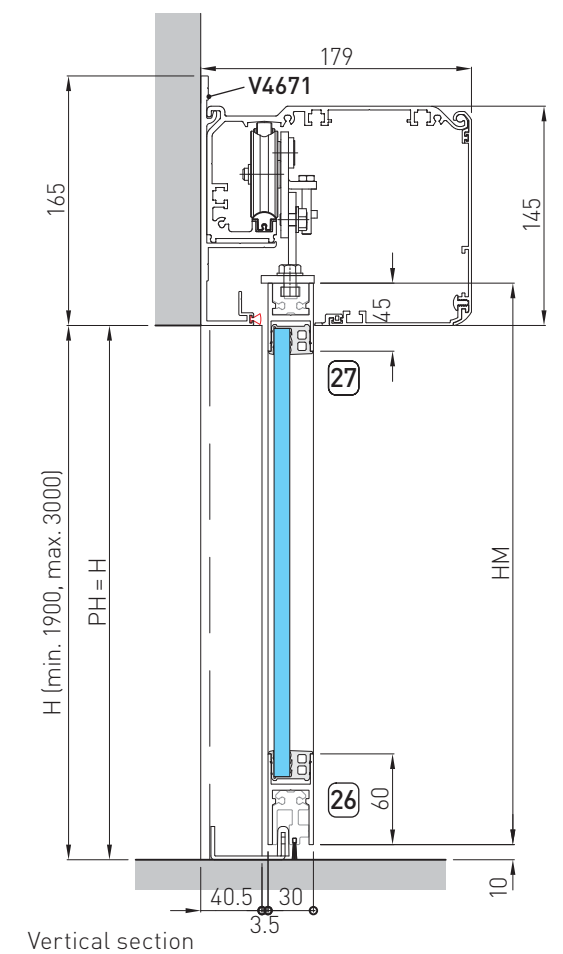
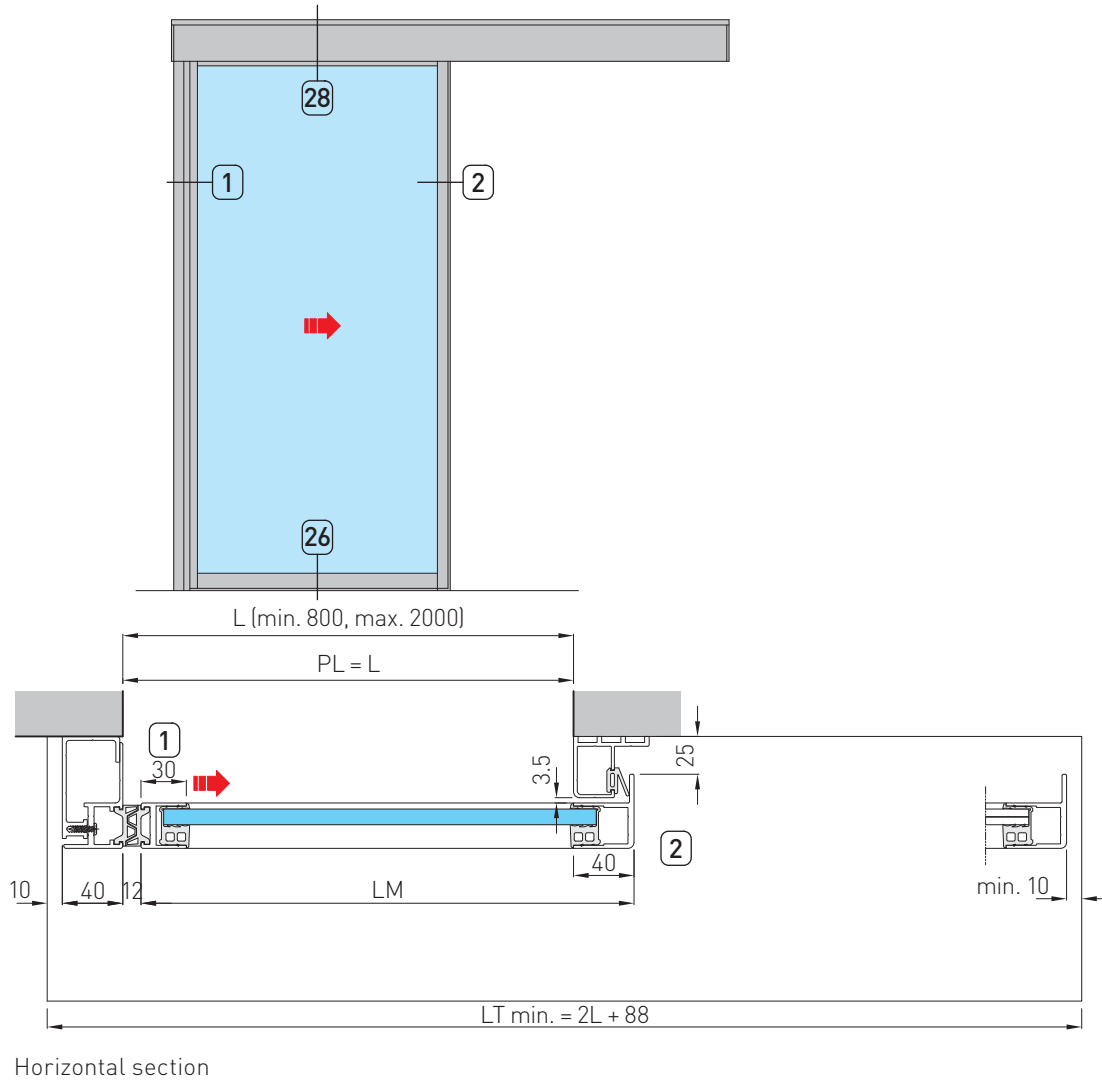

14. Vertical and horizontal section of 1 moving door wing with right-hand opening installed within doorway (french version)

Valor only (not Rex-S)

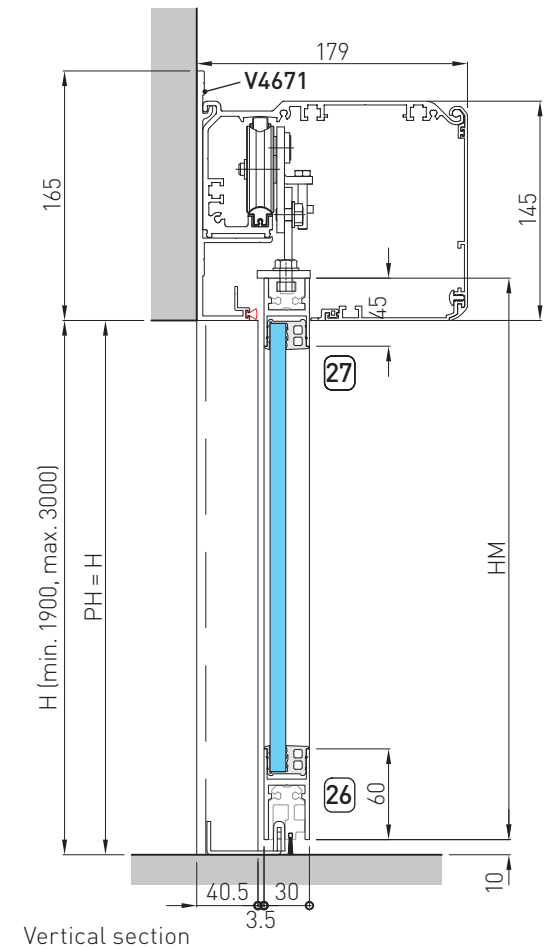
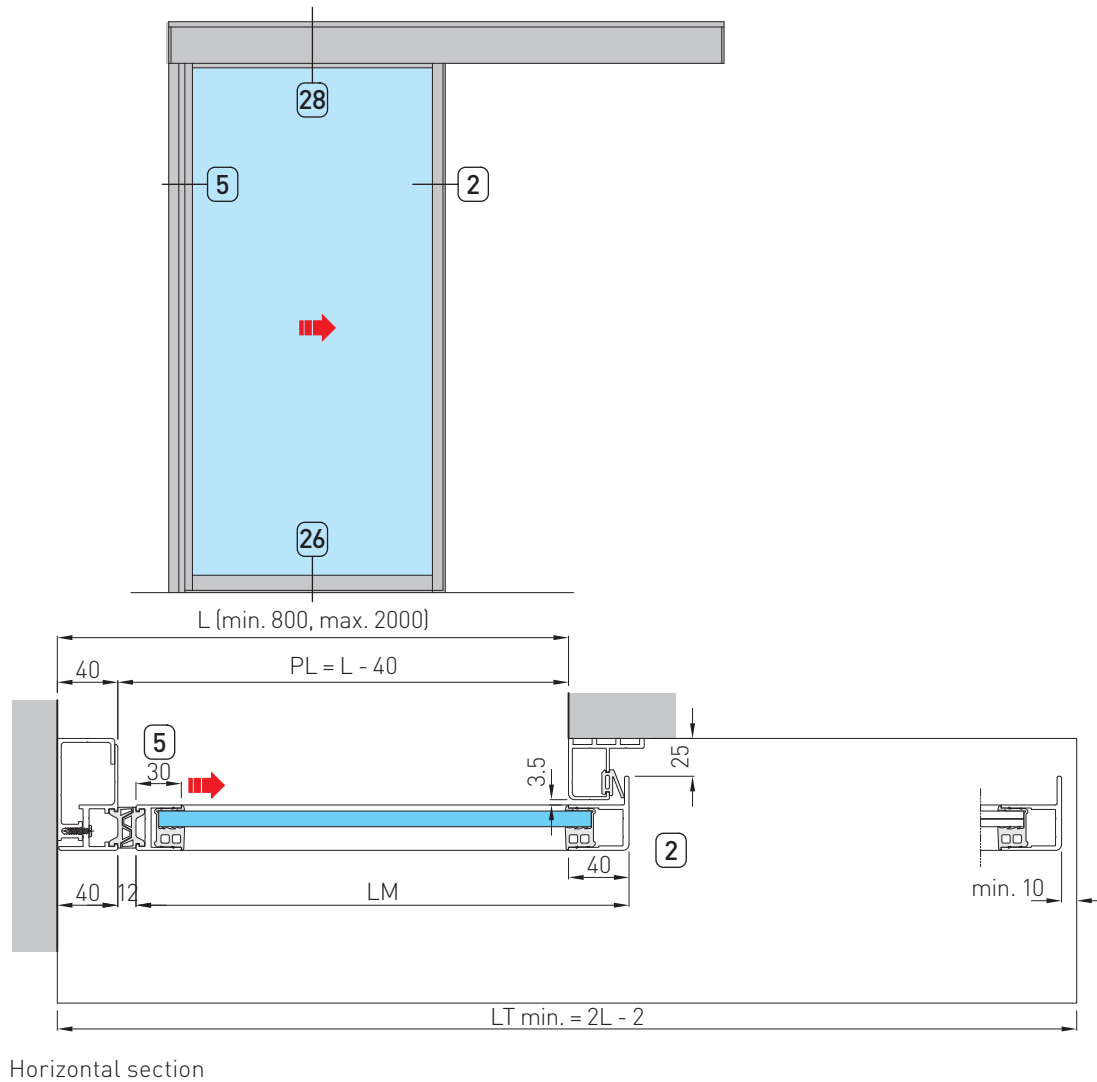

16. Vertical and horizontal section of 1 moving door wing with left-hand opening installed within doorway (french version)

T21

Valor only (not Rex-S)

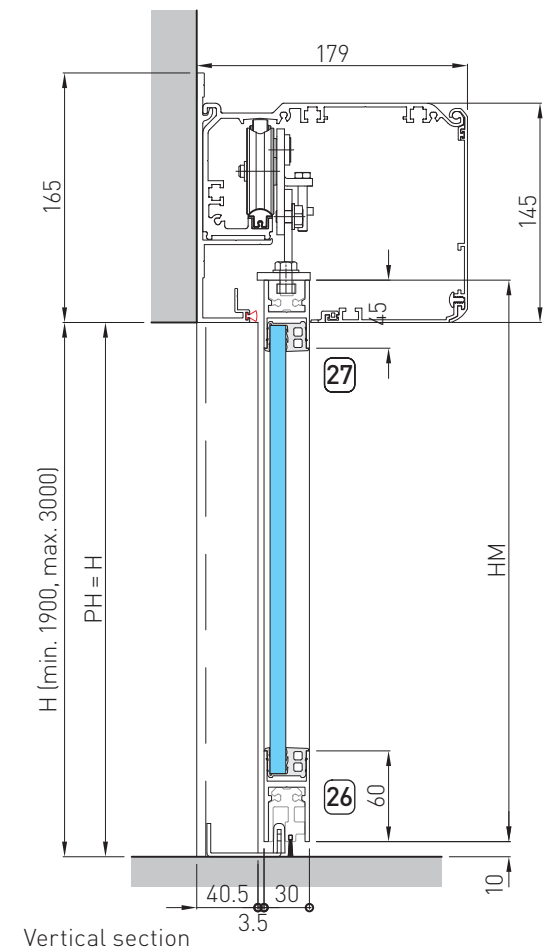
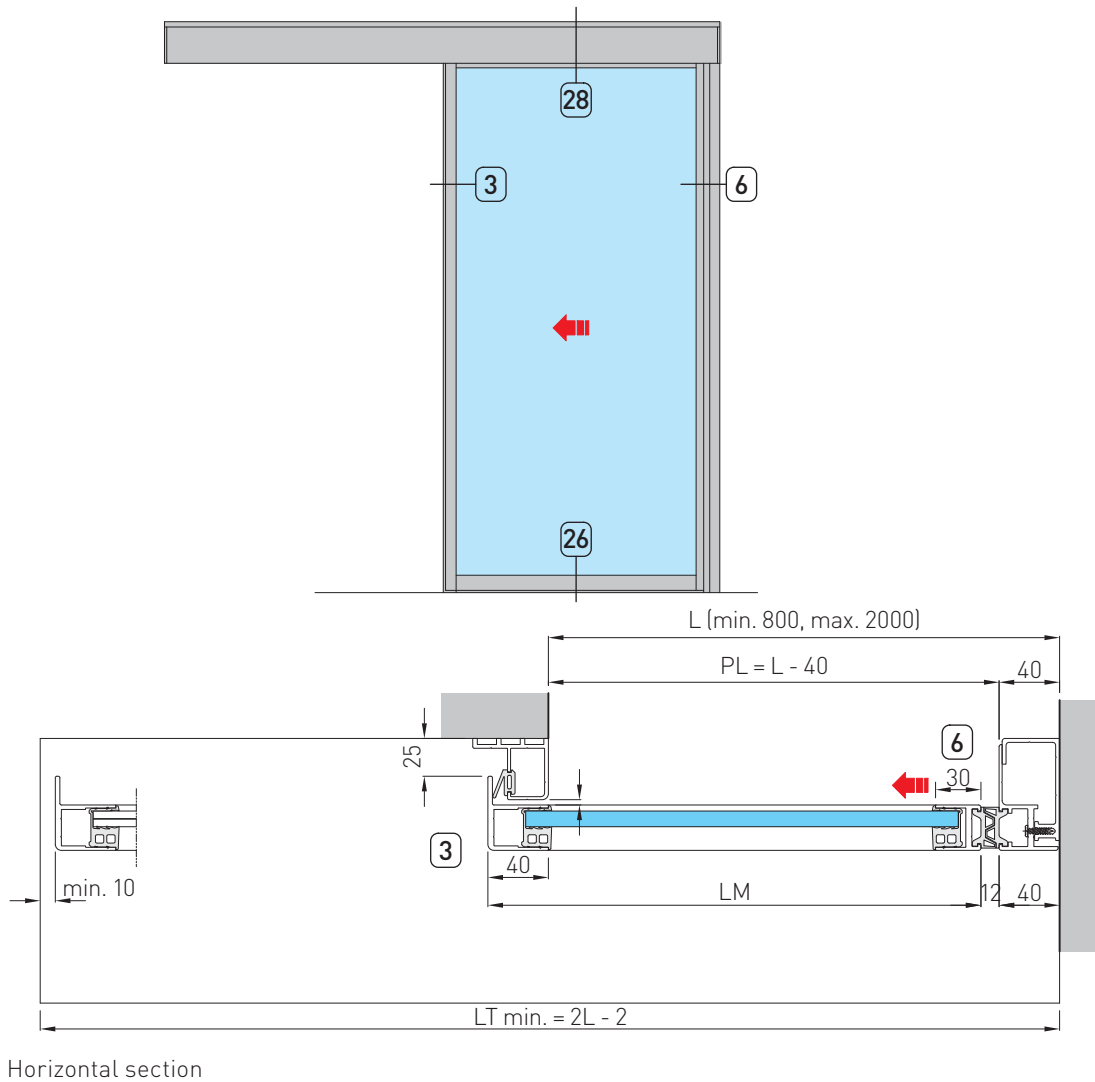

17. Vertical and horizontal section of 1 moving door wing with beam with right-hand opening (standard version)

T22

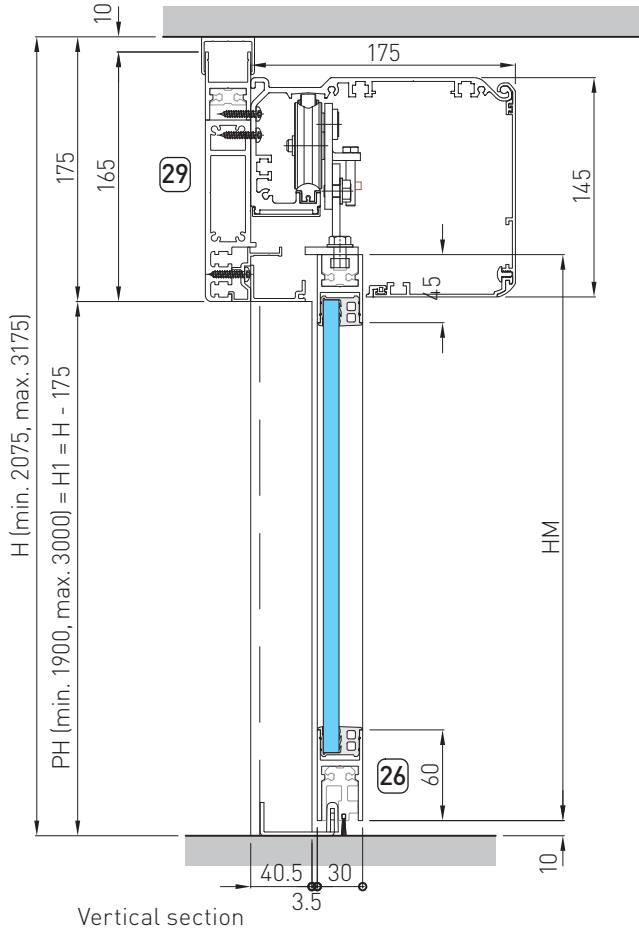
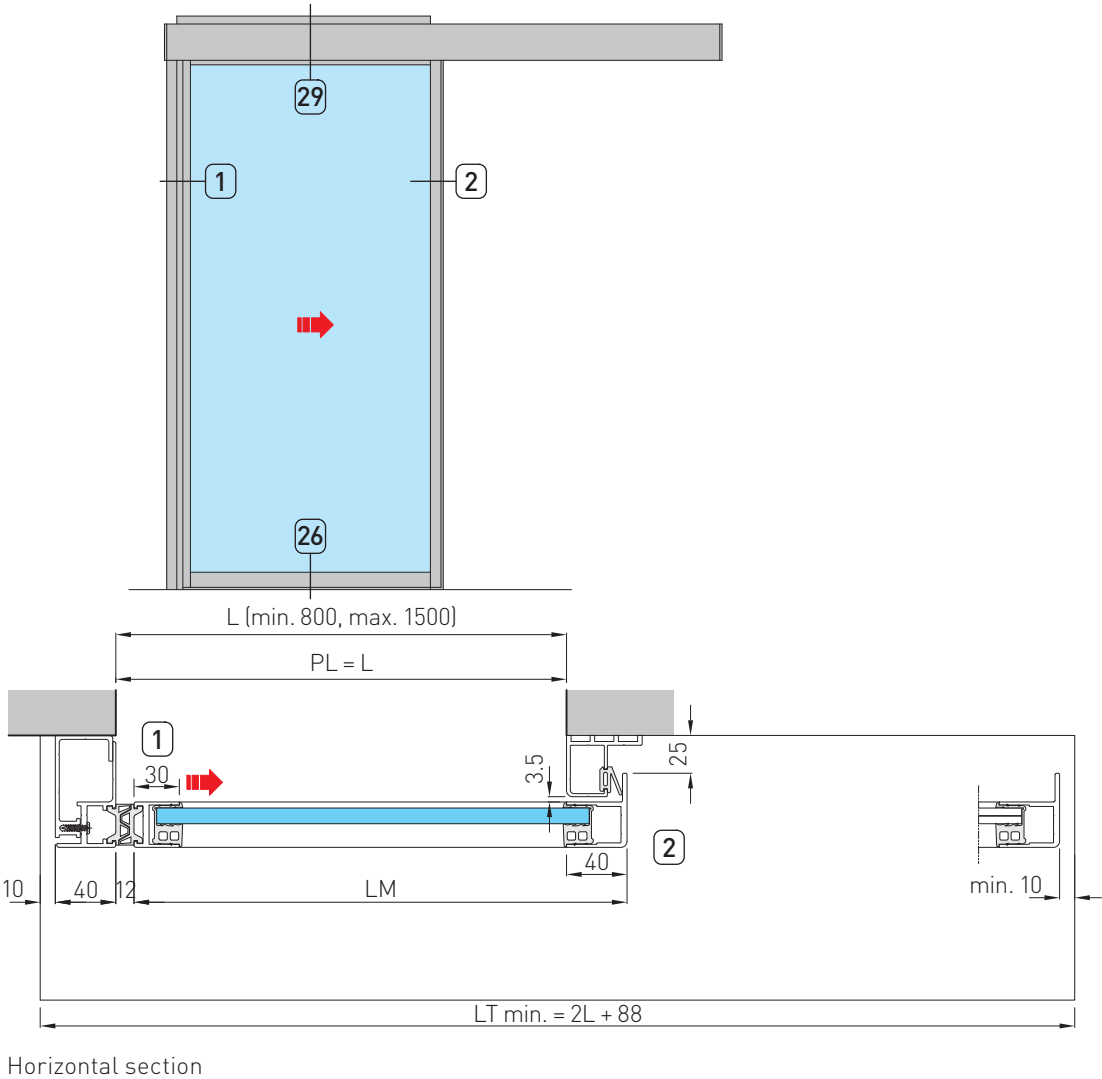

18. Vertical and horizontal section of 1 moving door wing with beam with right-hand opening installed within doorway (standard version)

T23N

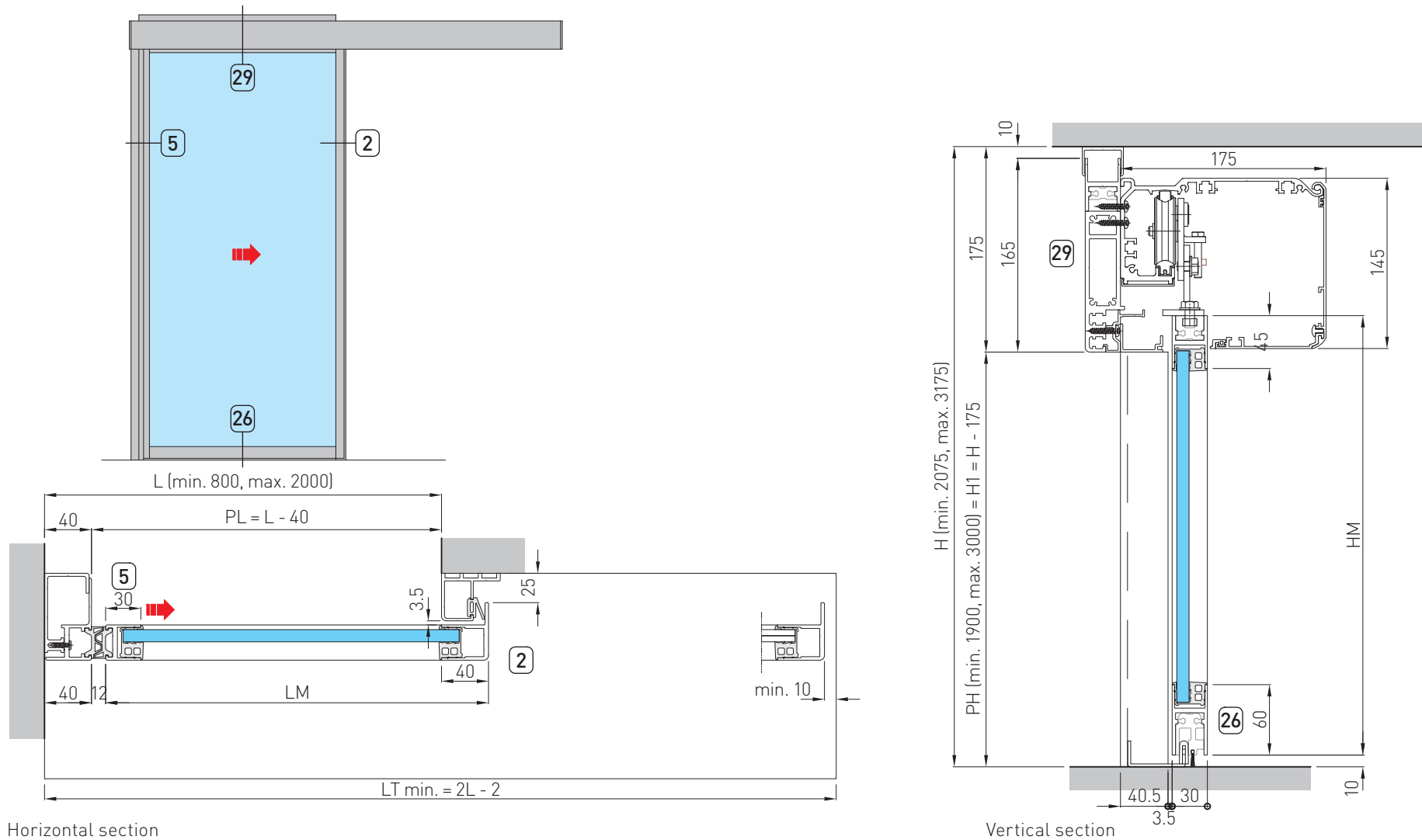

20. Vertical and horizontal section of 1 moving door wing with beam with left-hand opening installed within doorway (standard version)

T25N

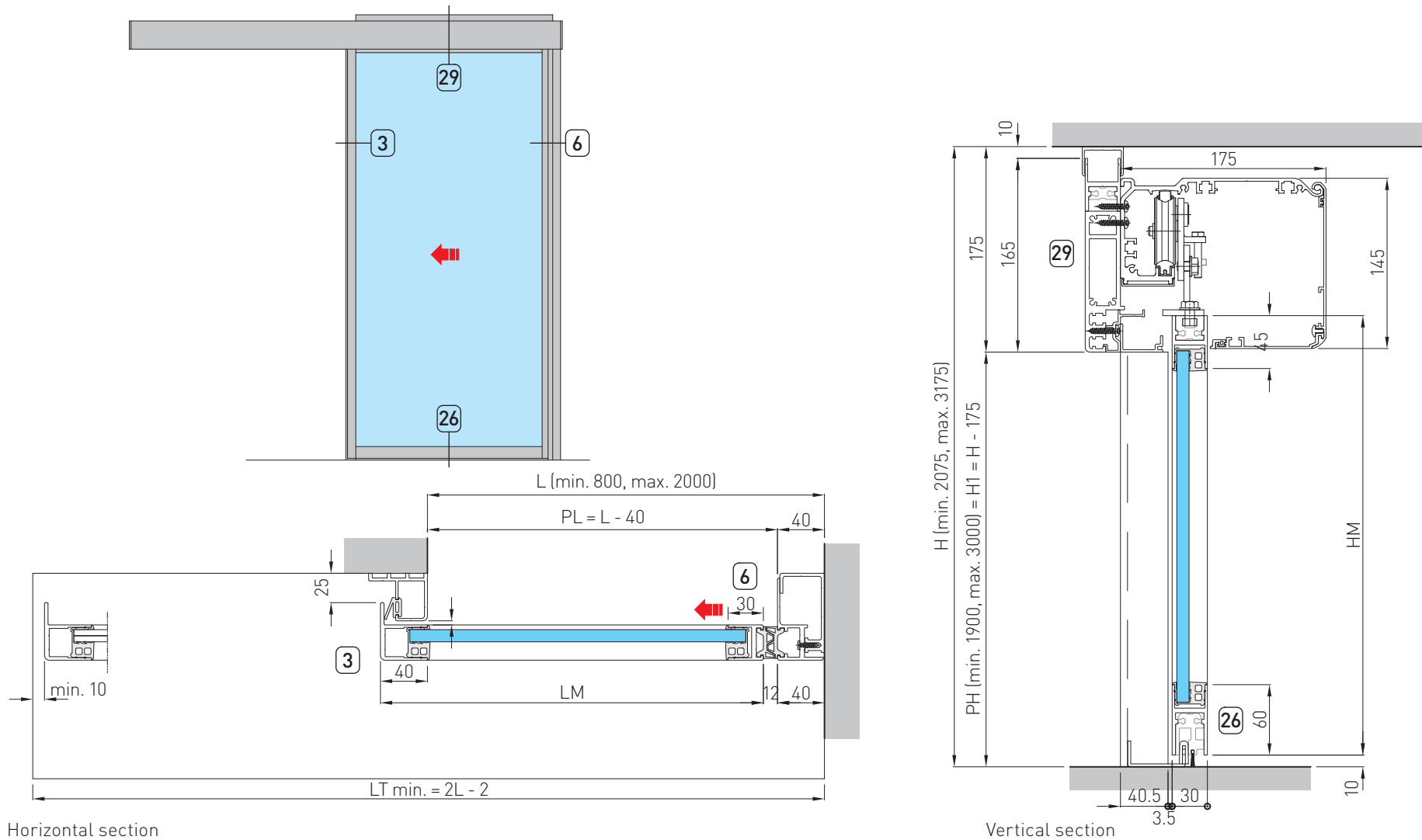

21. Vertical and horizontal section of 1 moving door wing with right-hand opening and overlight (standard version)

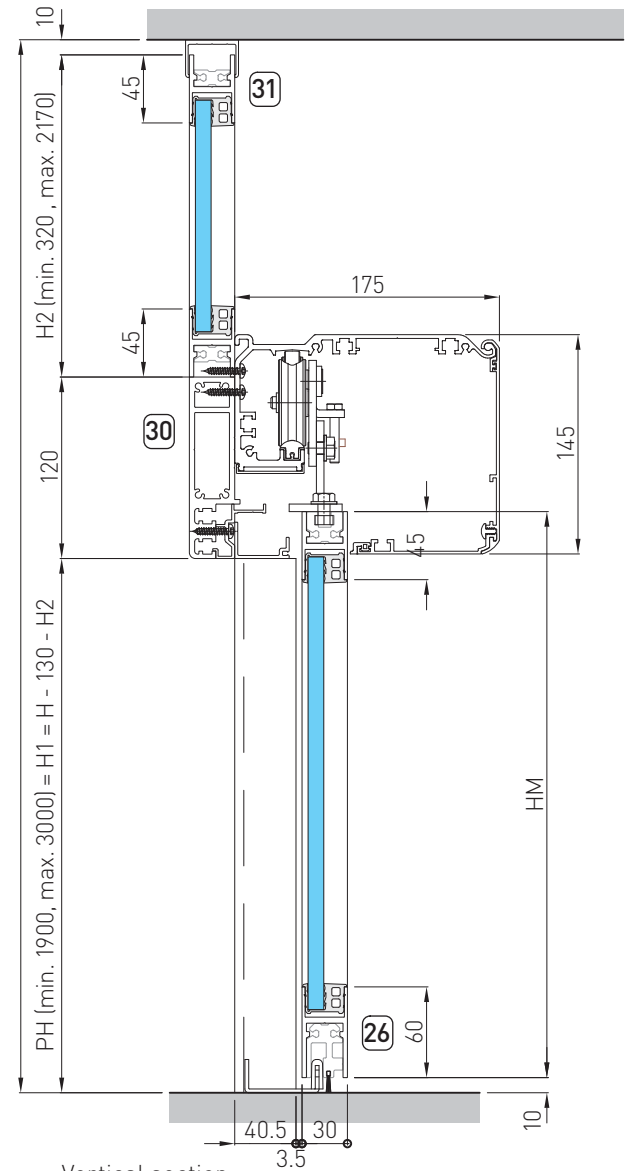
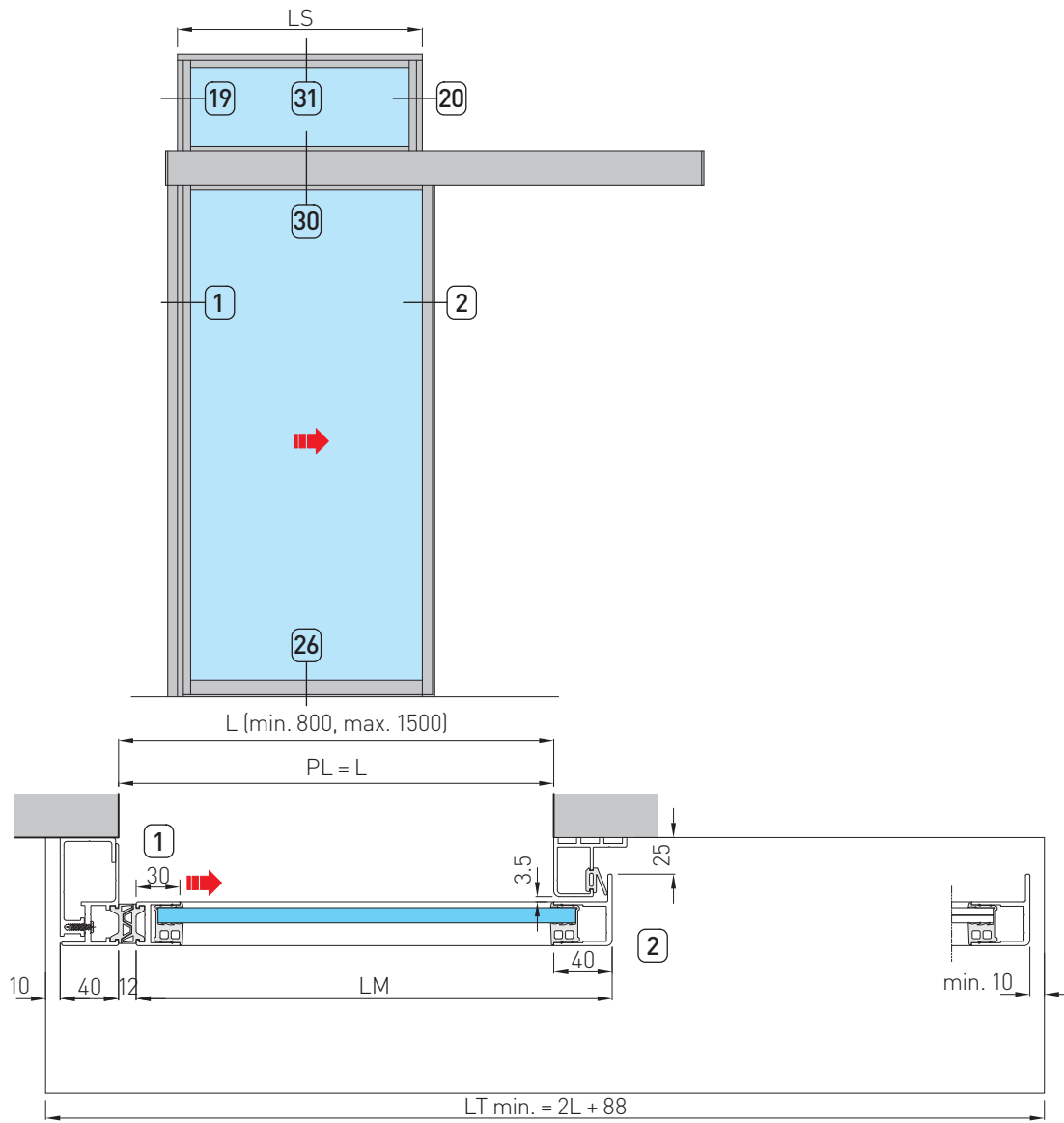

22. Vertical and horizontal section of 1 moving door wing with right-hand opening installed within doorway and overlight (standard version)

T27N

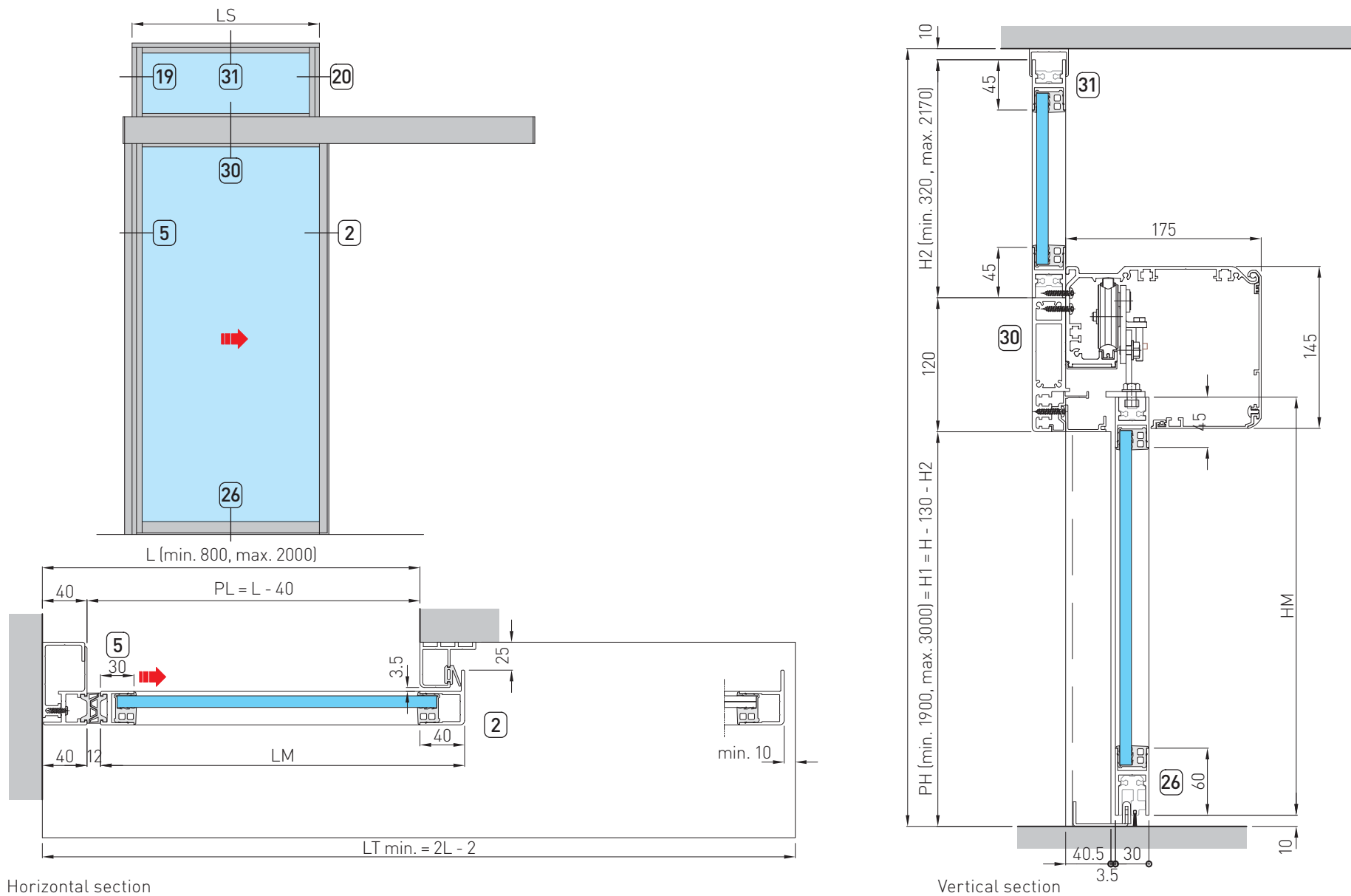

24. Vertical and horizontal section of 1 moving door wing with left-hand opening installed within doorway and overlight (standard version)

T29N

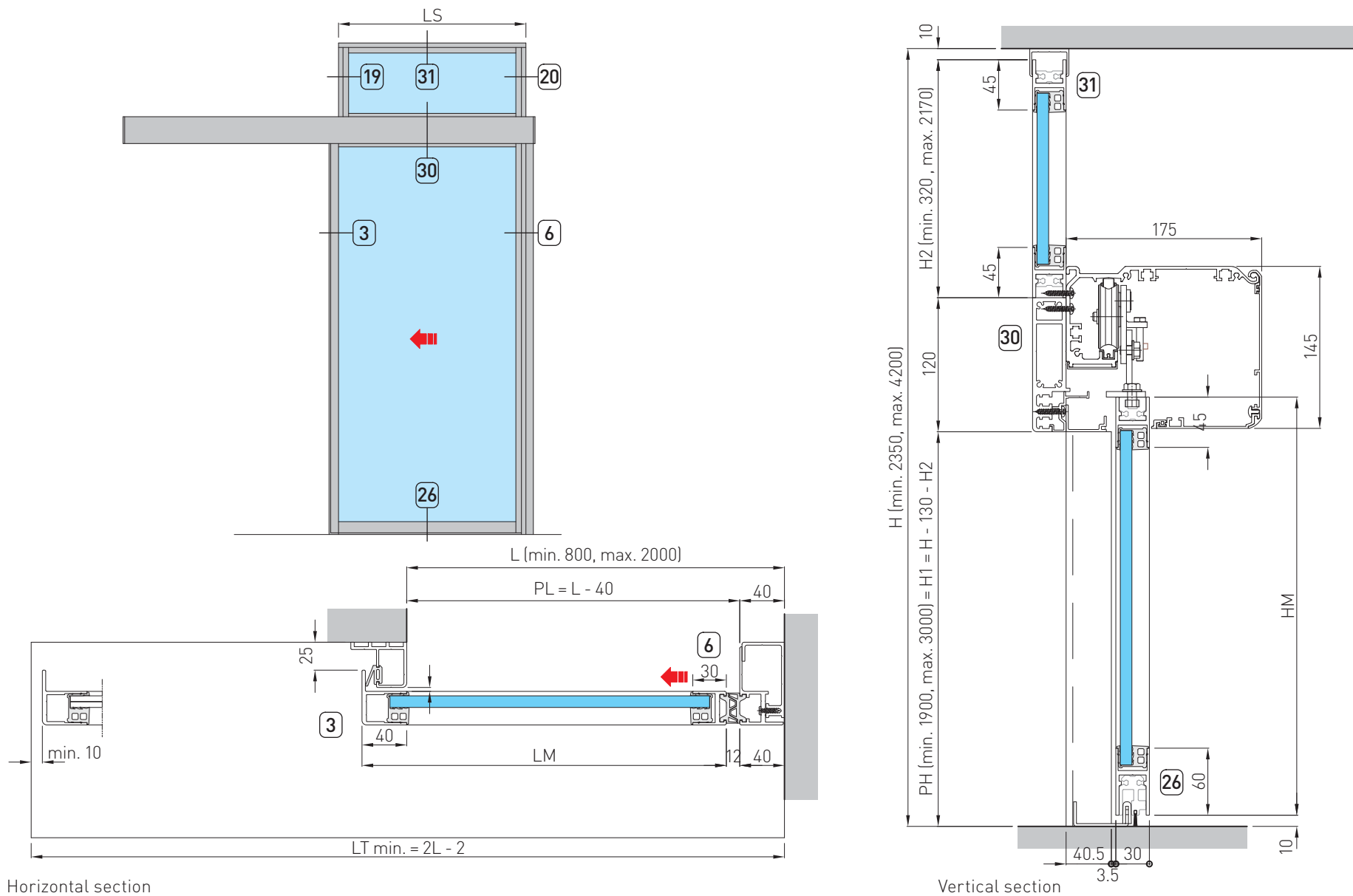

25. Vertical and horizontal section of 1 moving door wing and 1 fixed door wing with right-hand opening (french version)

T30

Valor only (not Rex-S)

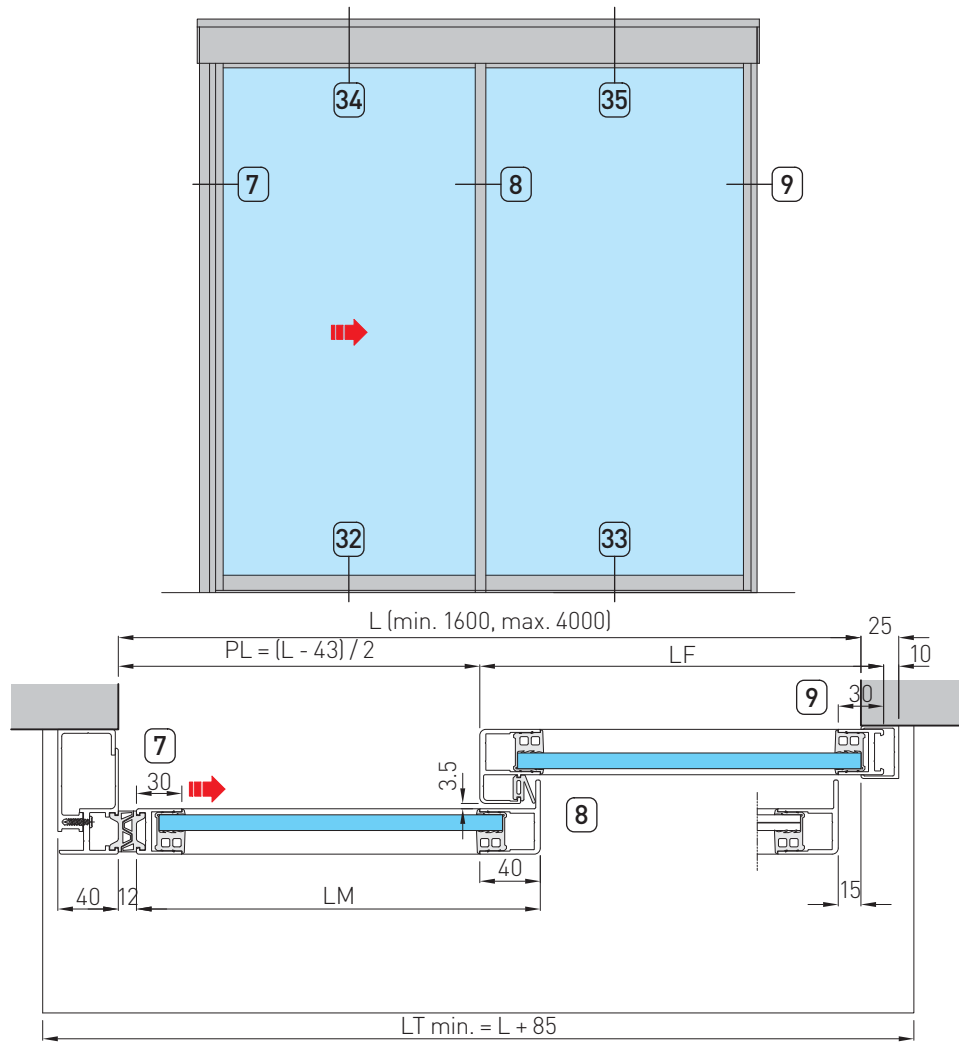

Horizontal section

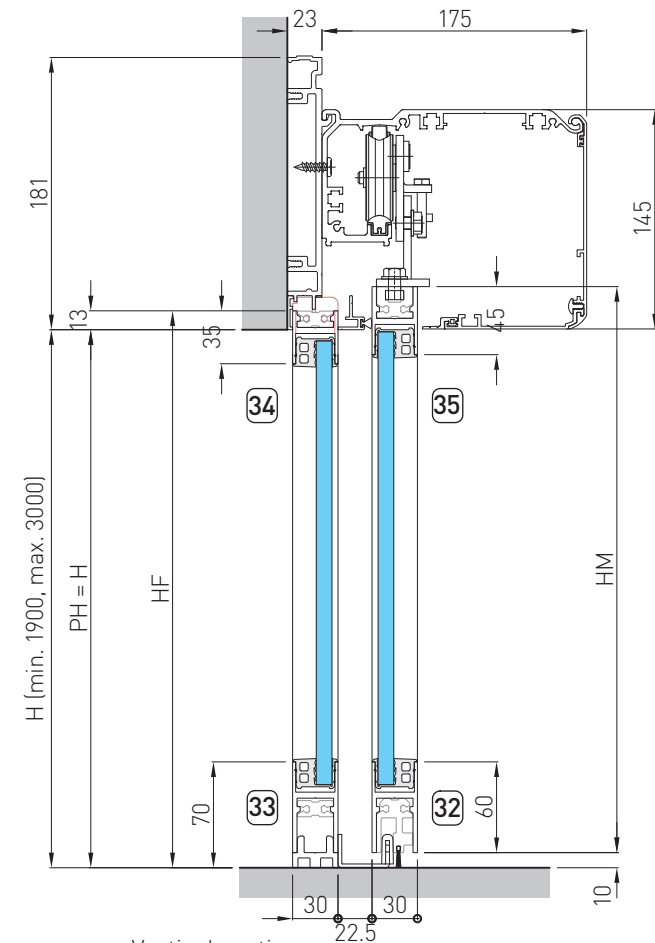

Vertical section

26. Vertical and horizontal section of 1 moving door wing and 1 fixed door wing with right-hand opening installed within doorway (french version)

T31

Valor only (not Rex-S)

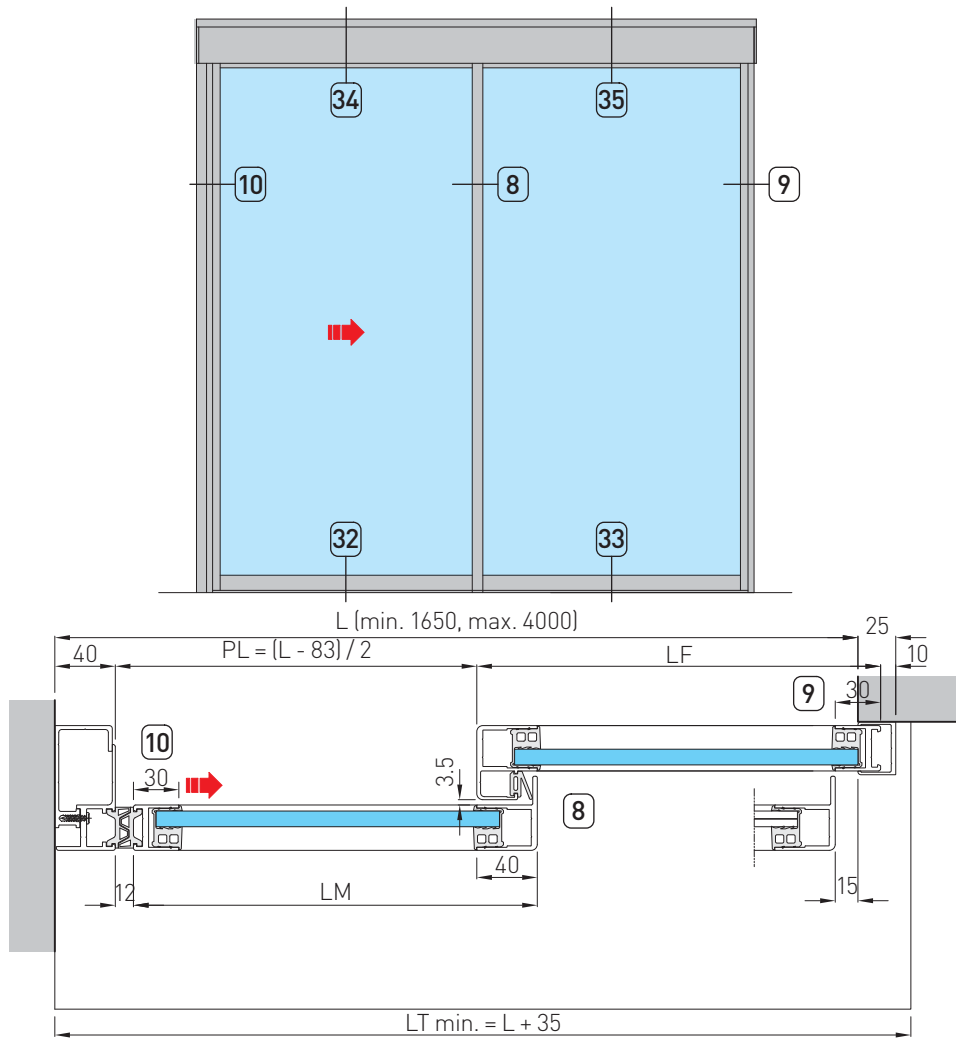

Horizontal section

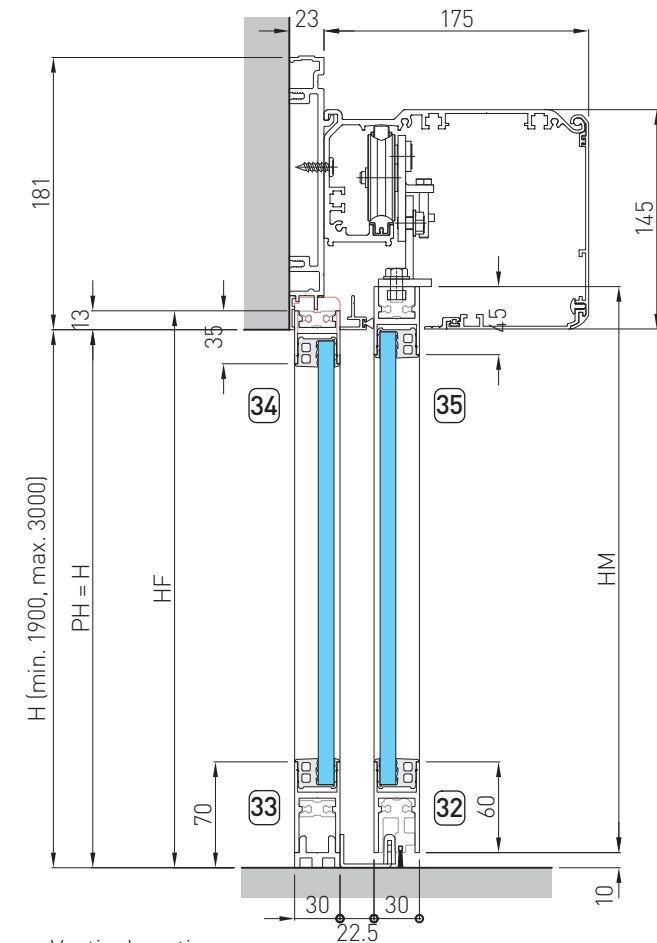

Vertical section

27. Vertical and horizontal section of 1 moving door wing and 1 fixed door wing with left-hand opening (french version)

T32

Valor only (not Rex-S)

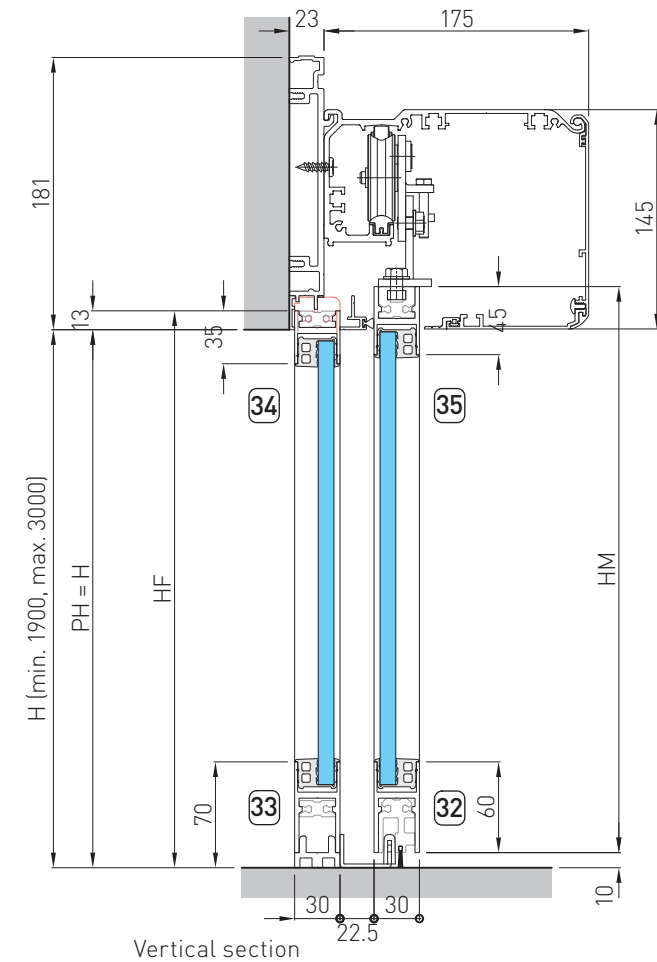
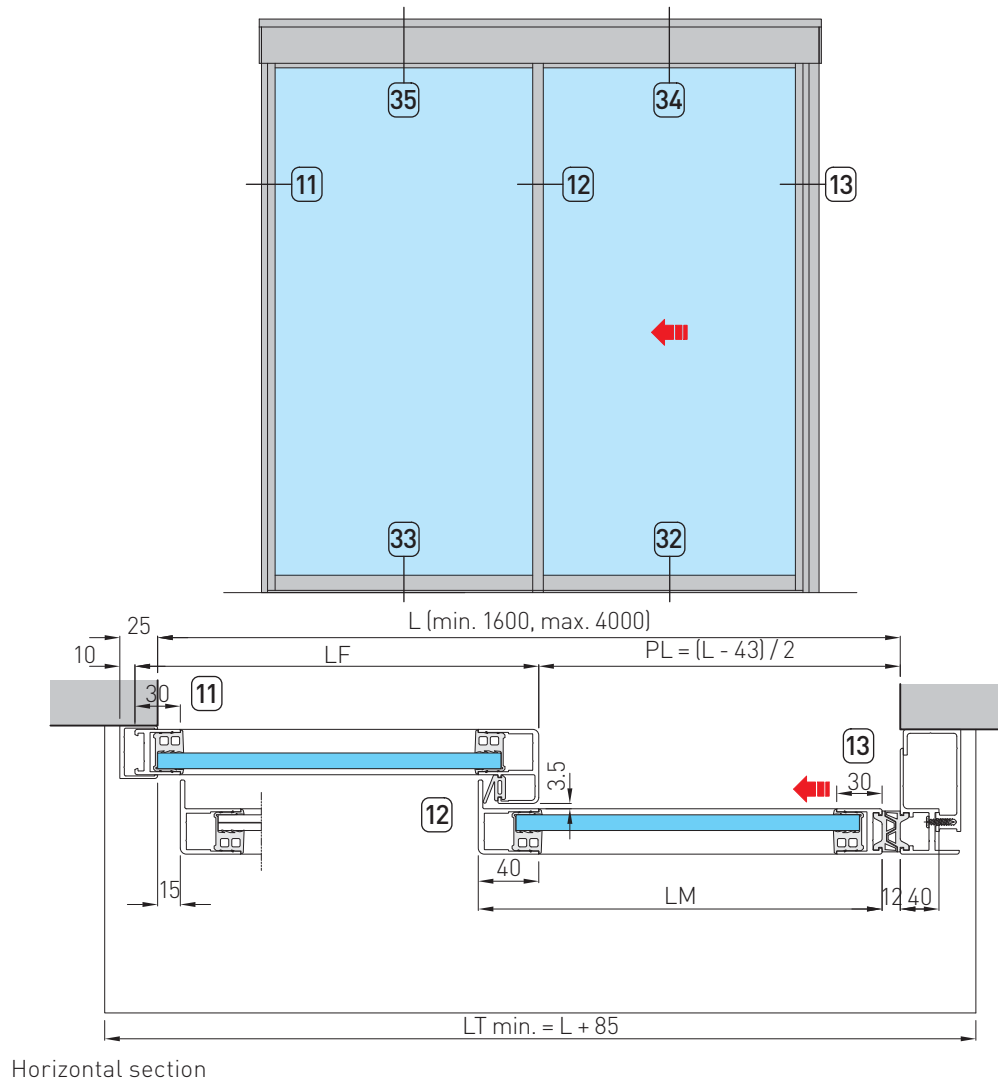

28. Vertical and horizontal section of 1 moving door wing and 1 fixed door wing with left-hand opening installed within doorway (french version)

T33

Valor only (not Rex-S)

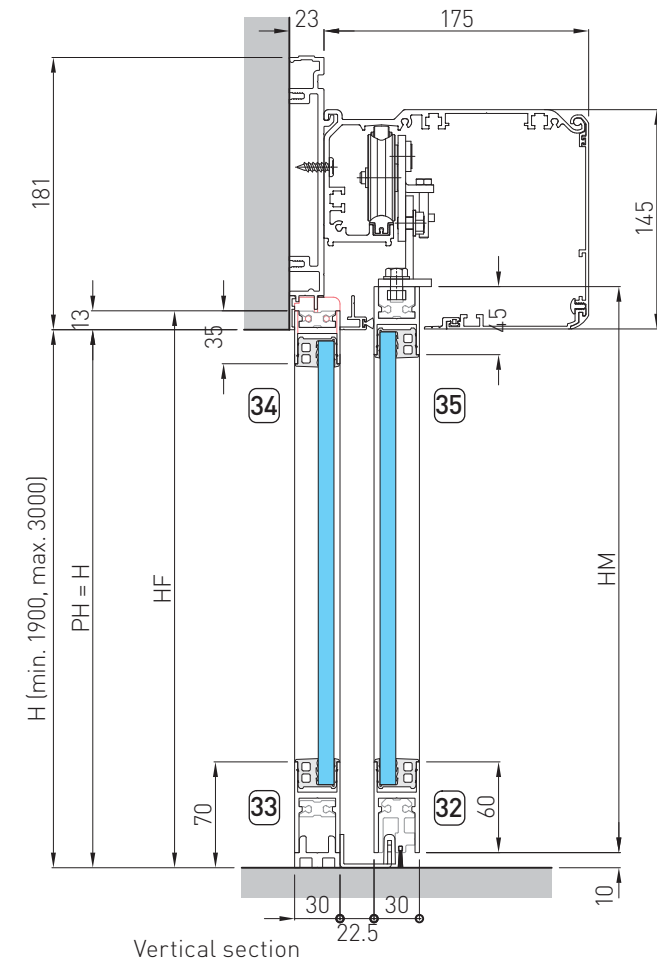
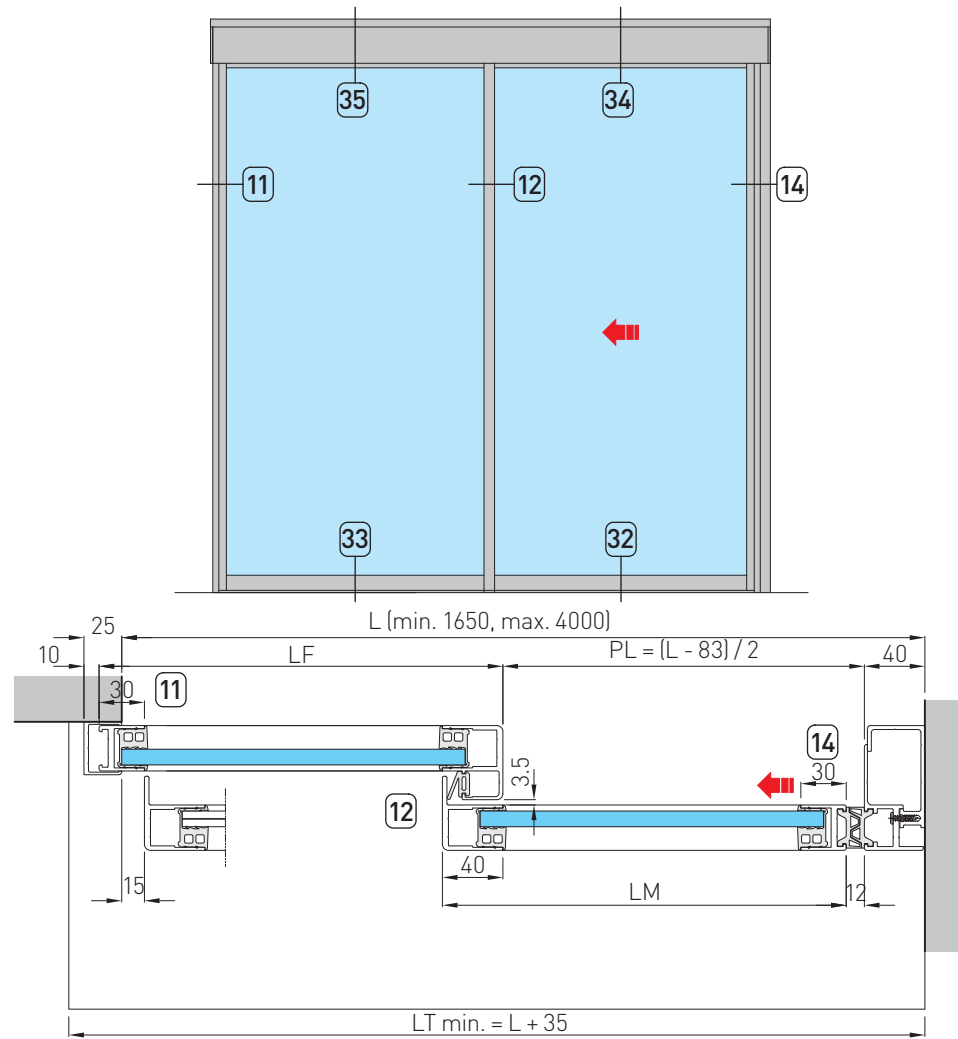

29. Vertical and horizontal section of 1 moving door wing and 1 fixed door wing with beam with right-hand opening (standard version)

T34

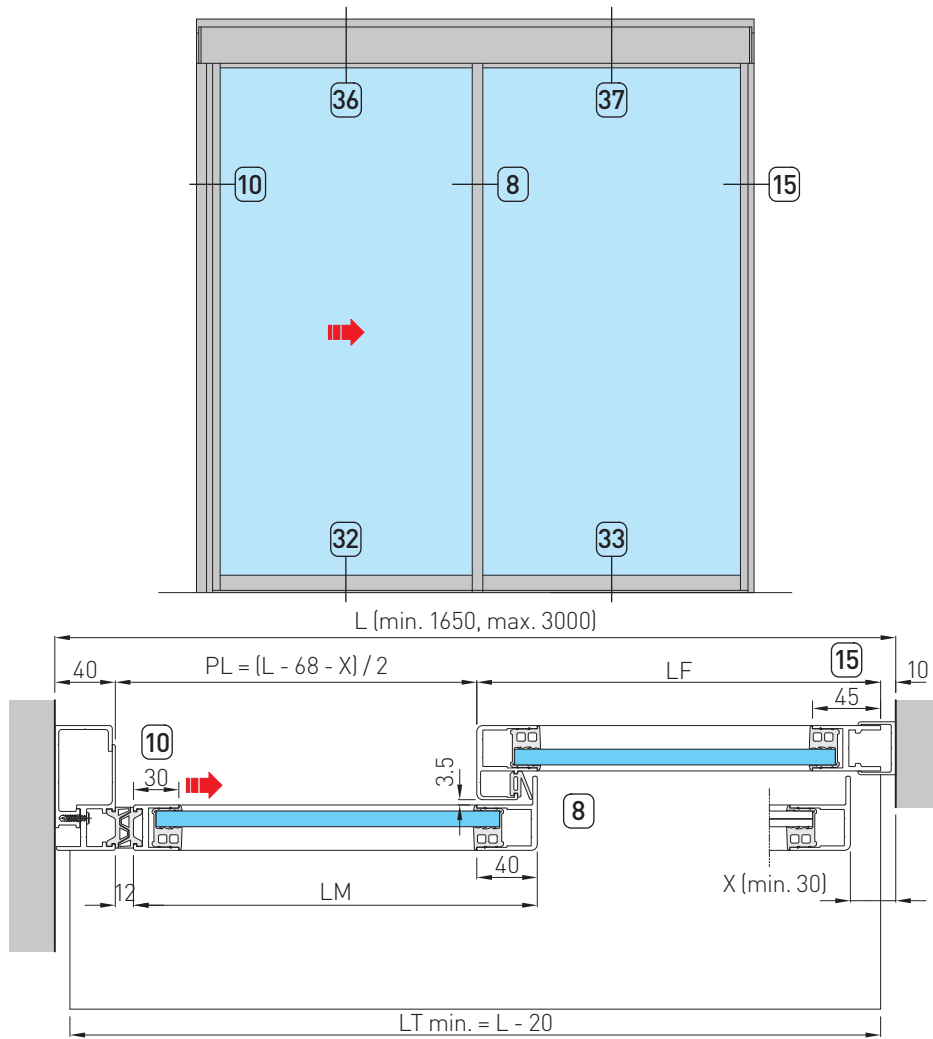

Horizontal section

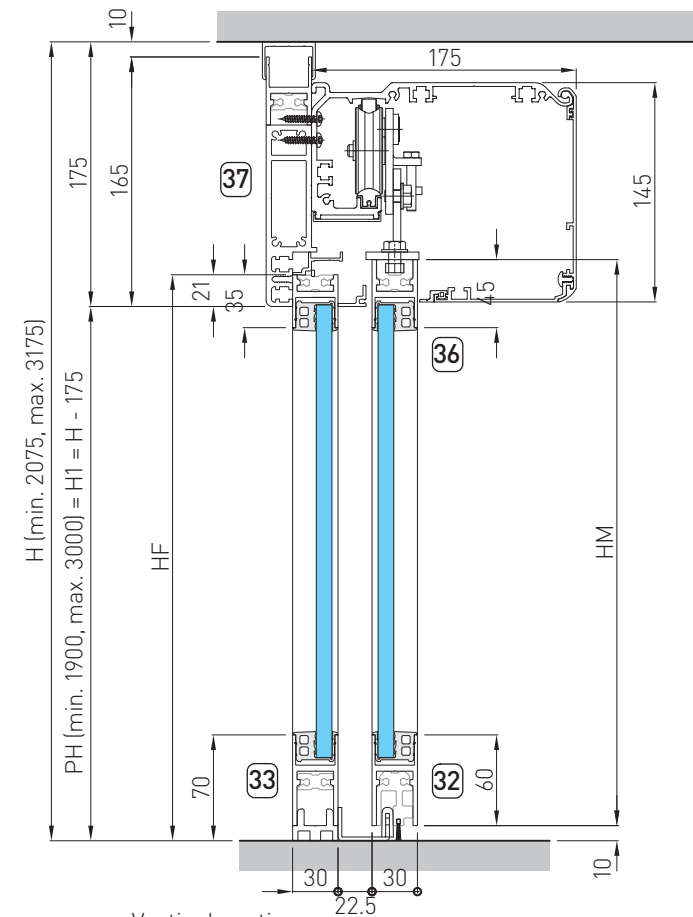

Vertical section

30. Vertical and horizontal section of 1 moving door wing and 1 fixed door wing with beam with left-hand opening (standard version)

T35

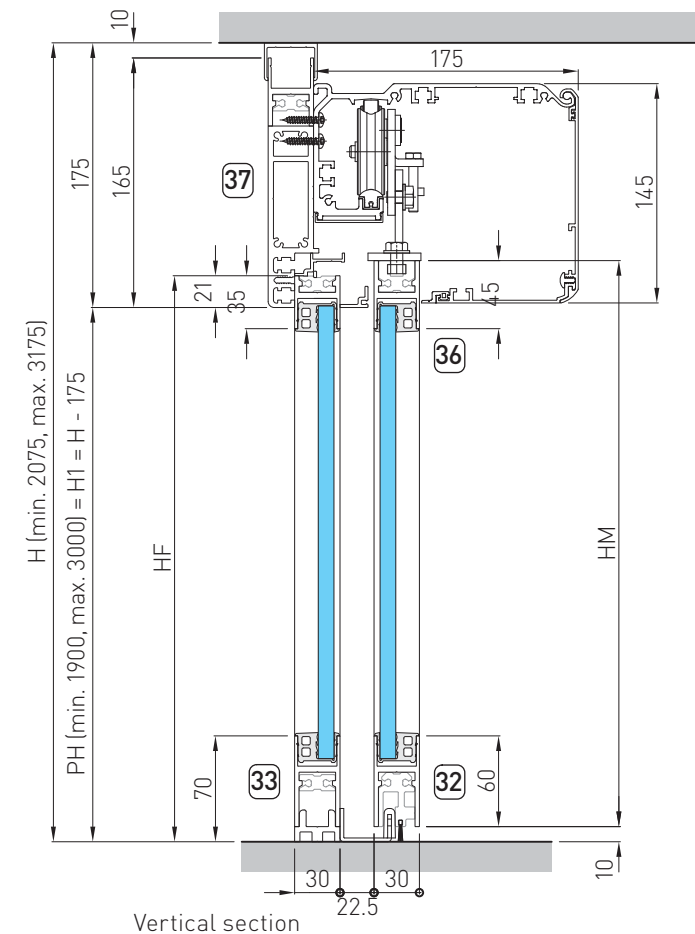
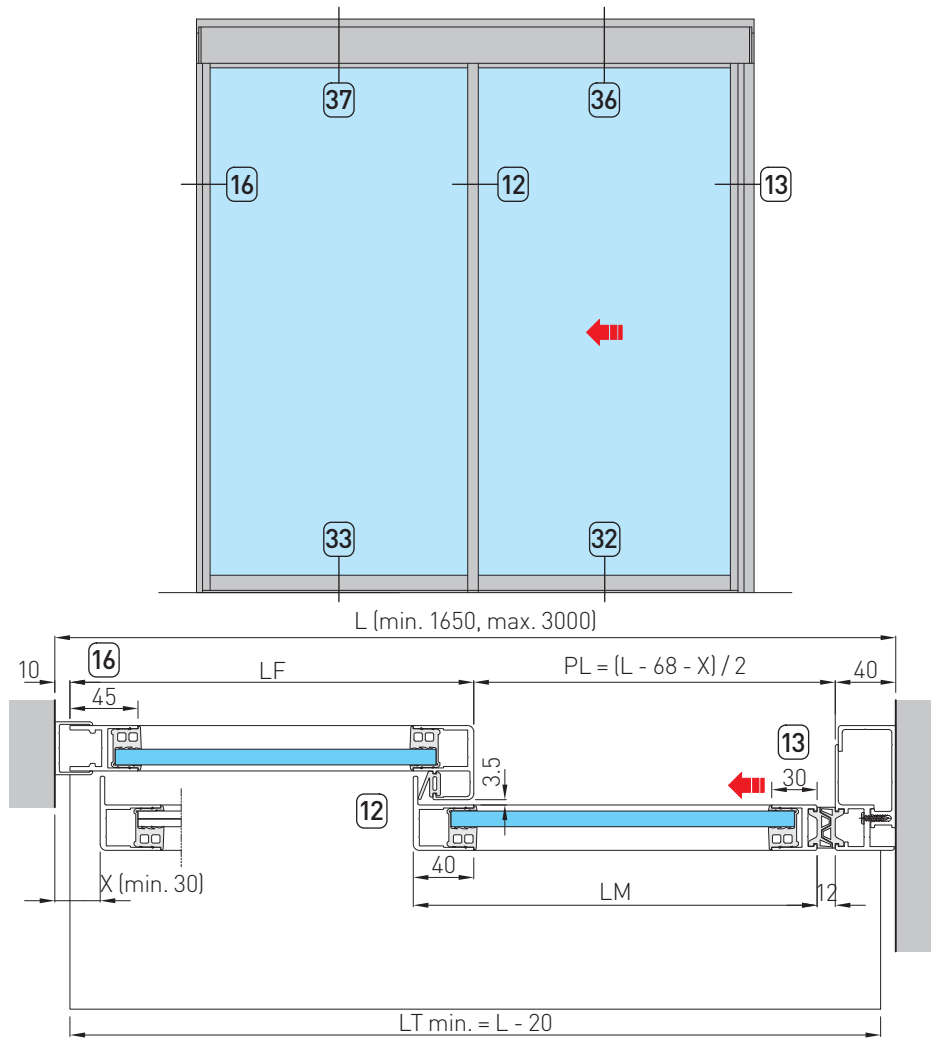

31. Vertical and horizontal section of 1 moving door wing and 1 fixed door wing with beam with right-hand opening (french version)

Valor only (not Rex-S)

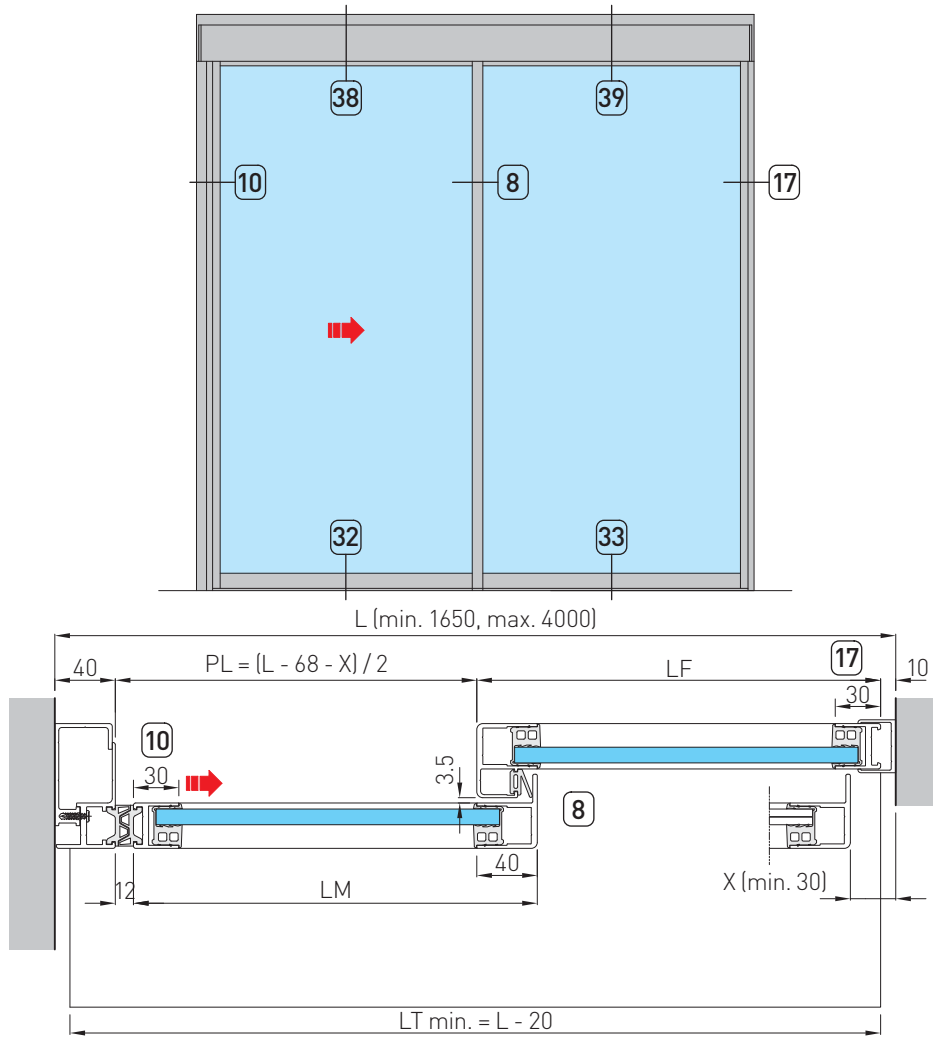

Horizontal section

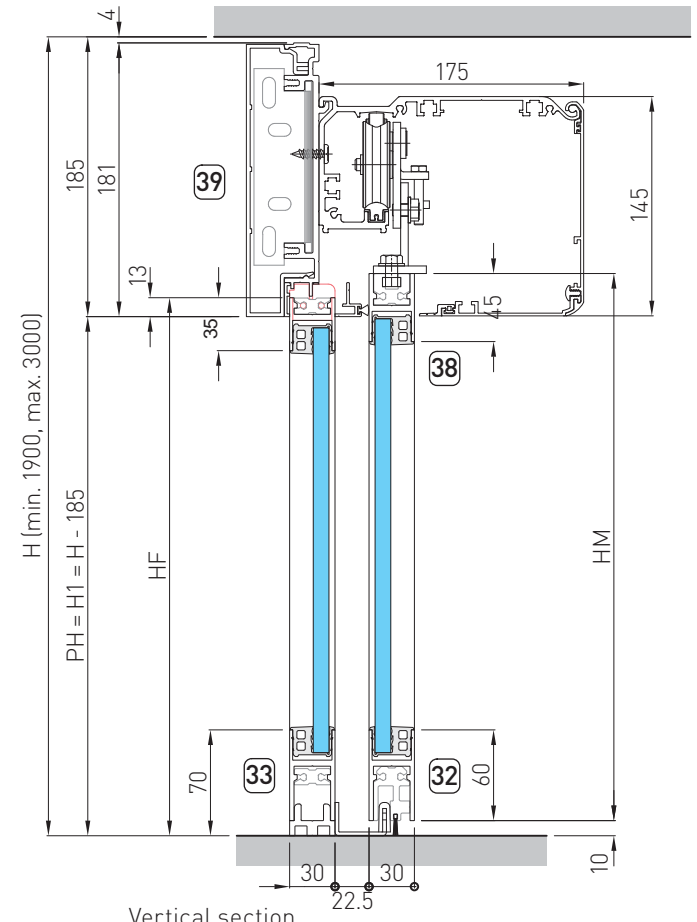

Vertical section

32. Vertical and horizontal section of 1 moving door wing and 1 fixed door wing with beam with left-hand opening (french version)

T37

Valor only (not Rex-S)

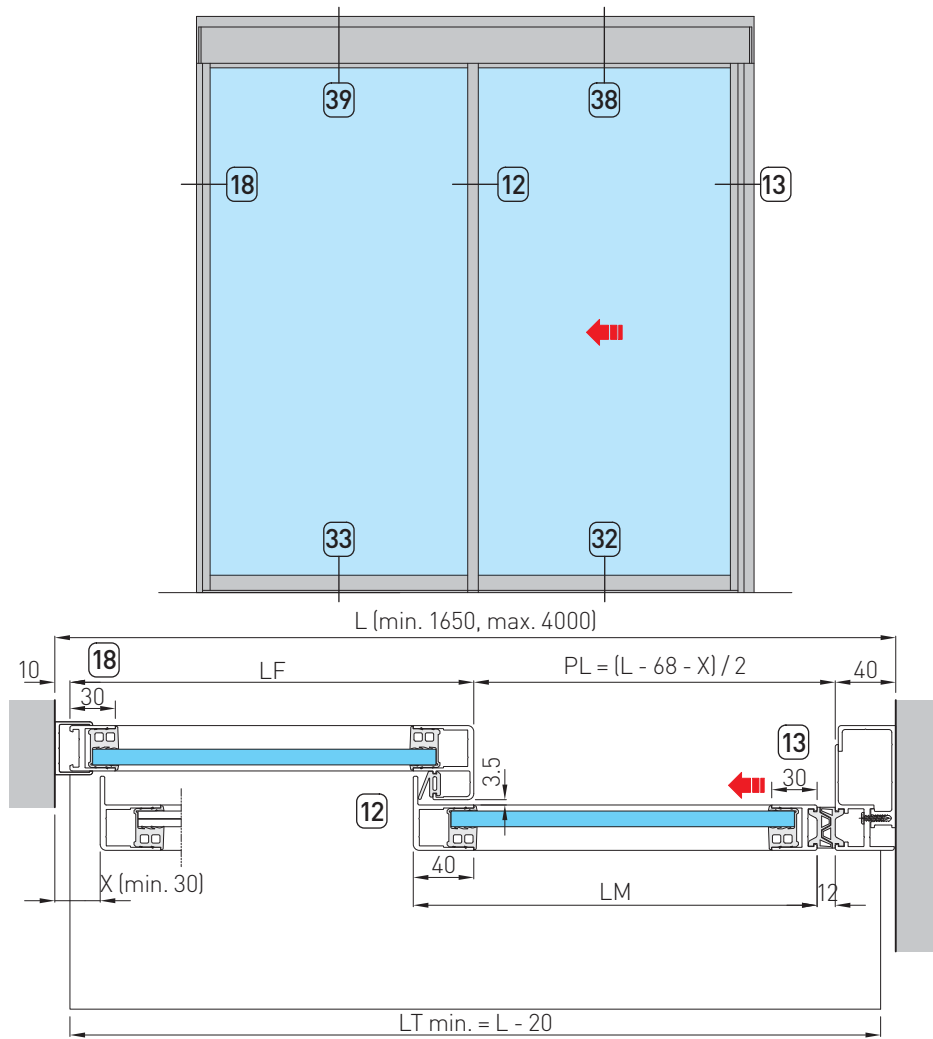

Horizontal section

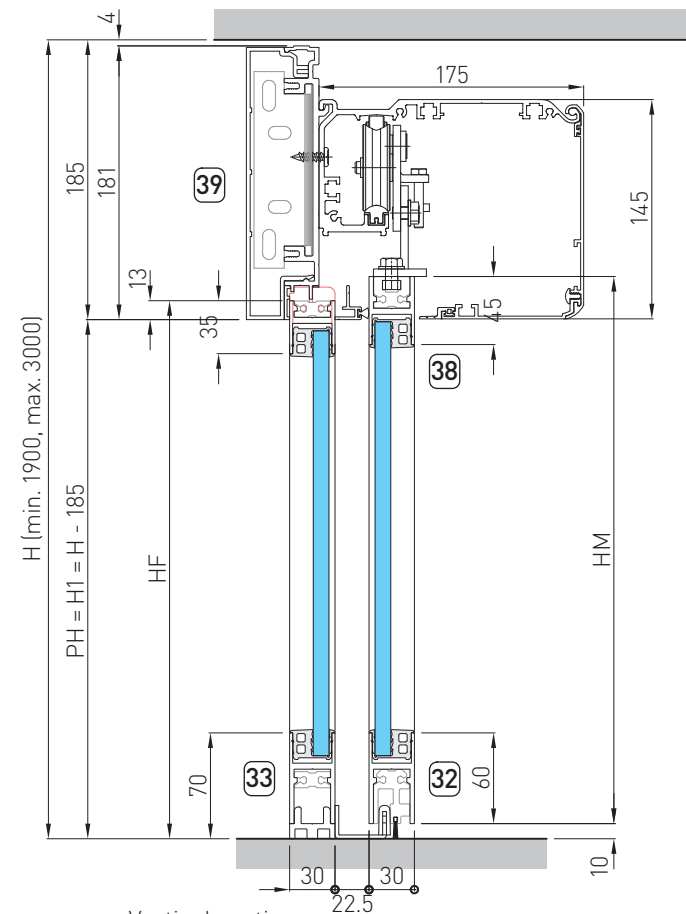

Vertical section

33. Vertical and horizontal section of 1 moving door wing and 1 fixed door wing with right-hand opening and overlight (standard version)

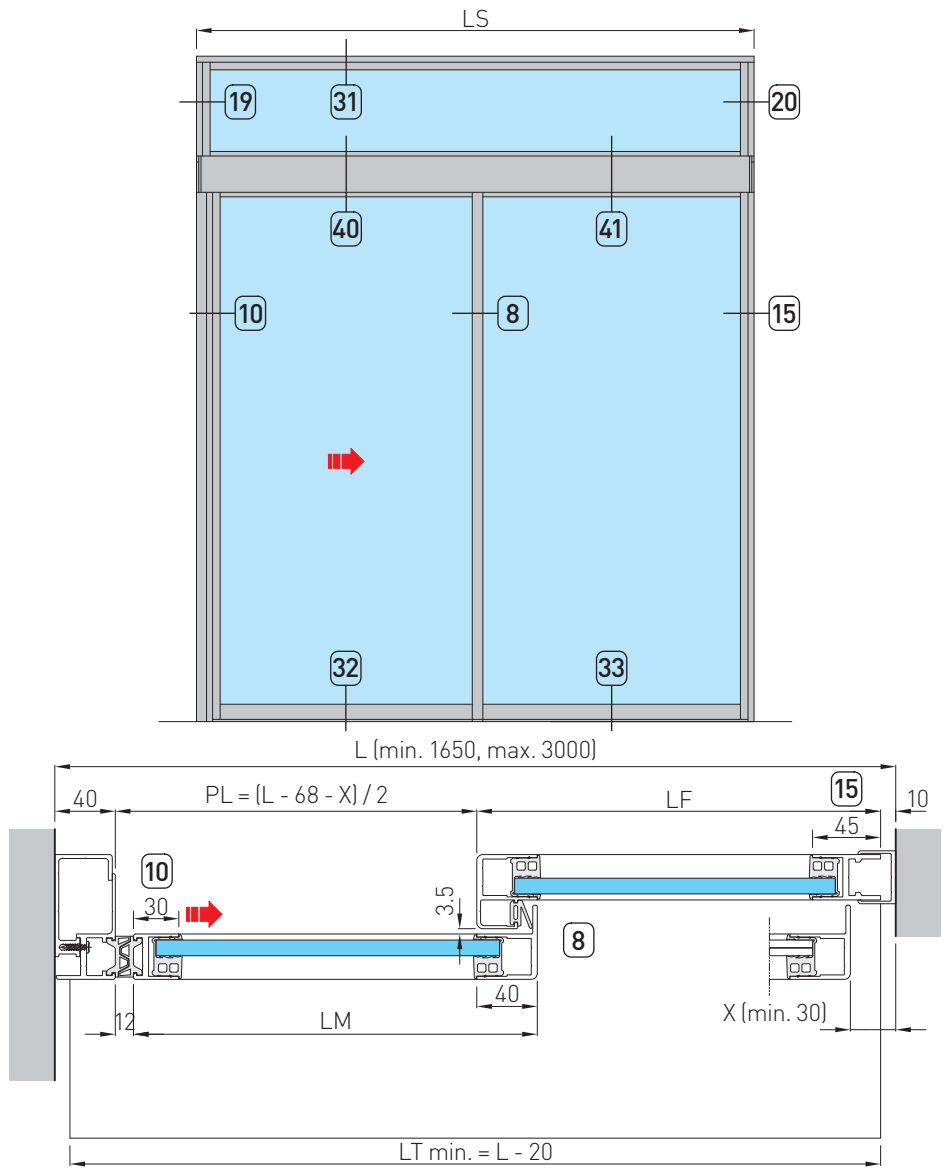

Horizontal section

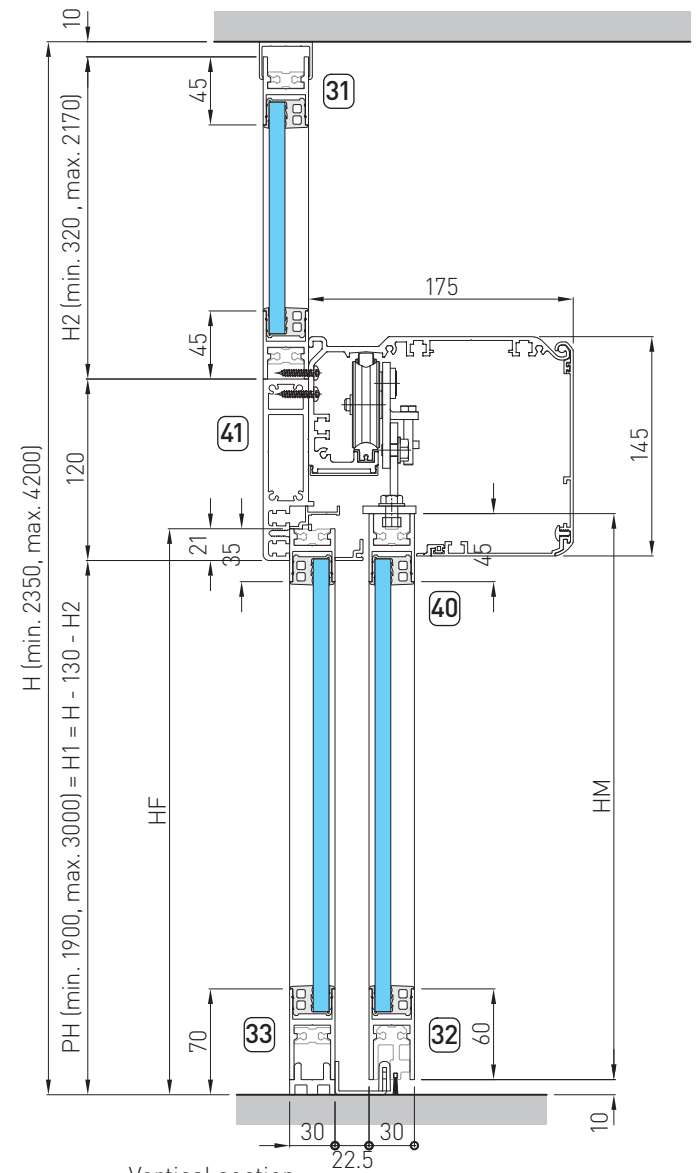

Vertical section

35. Vertical and horizontal section of 1 moving door wing and 1 fixed door wing with right-hand opening and overlight (french version)

T40

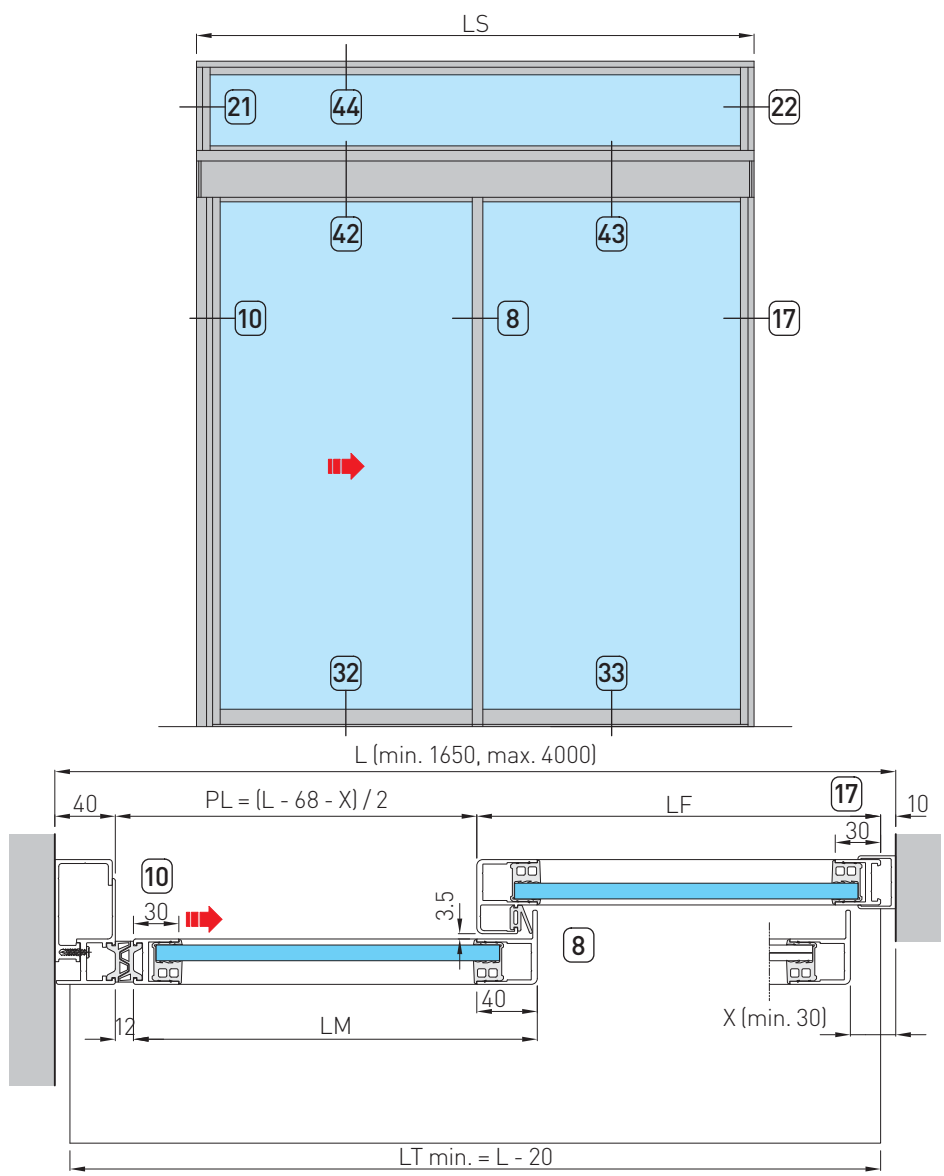

Horizontal section

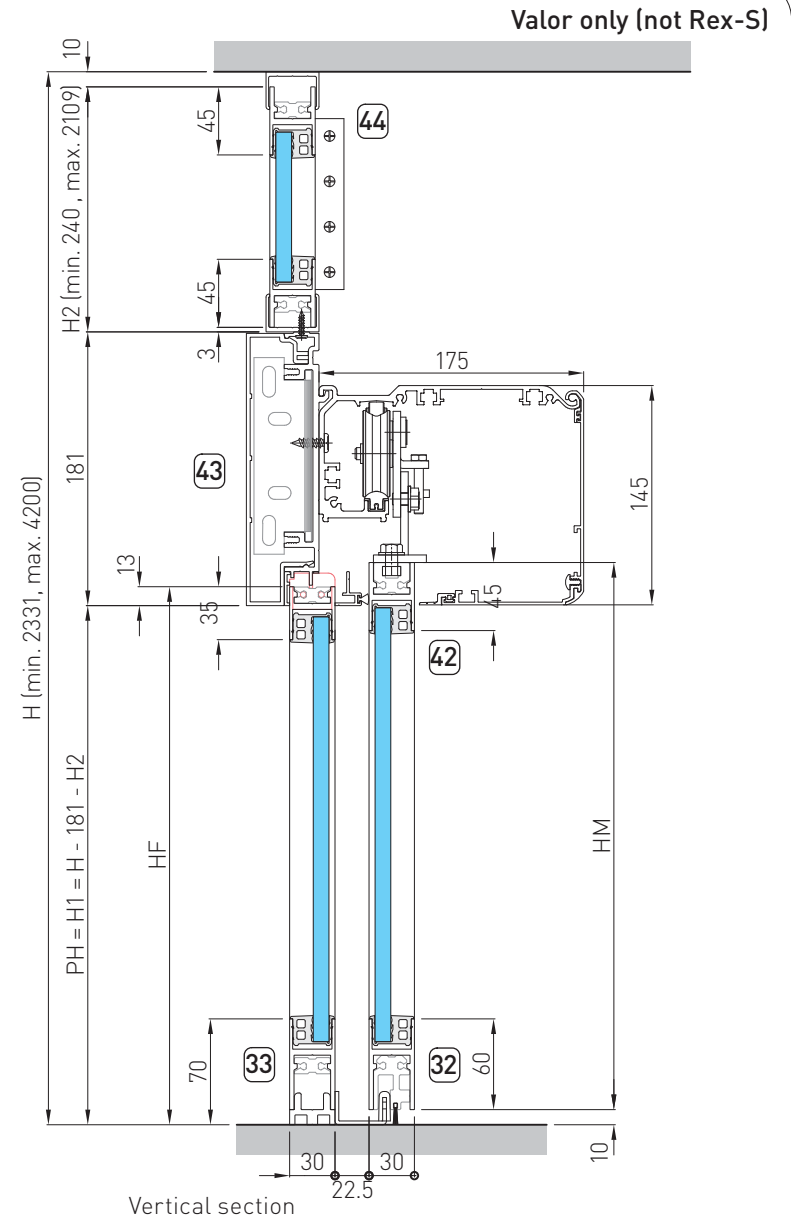

Vertical section

36. Vertical and horizontal section of 1 moving door wing and 1 fixed door wing with left-hand opening and overhead (french version)

T41

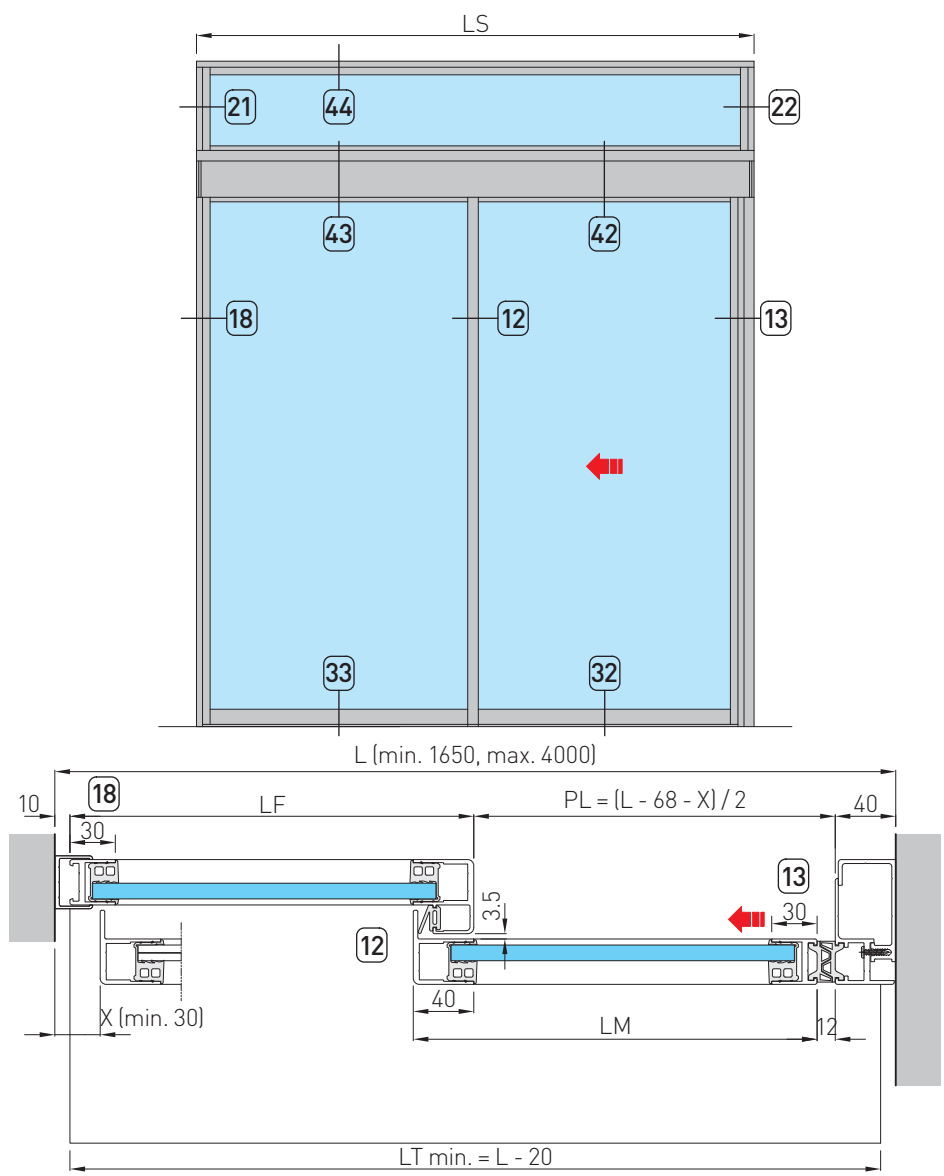

Horizontal section

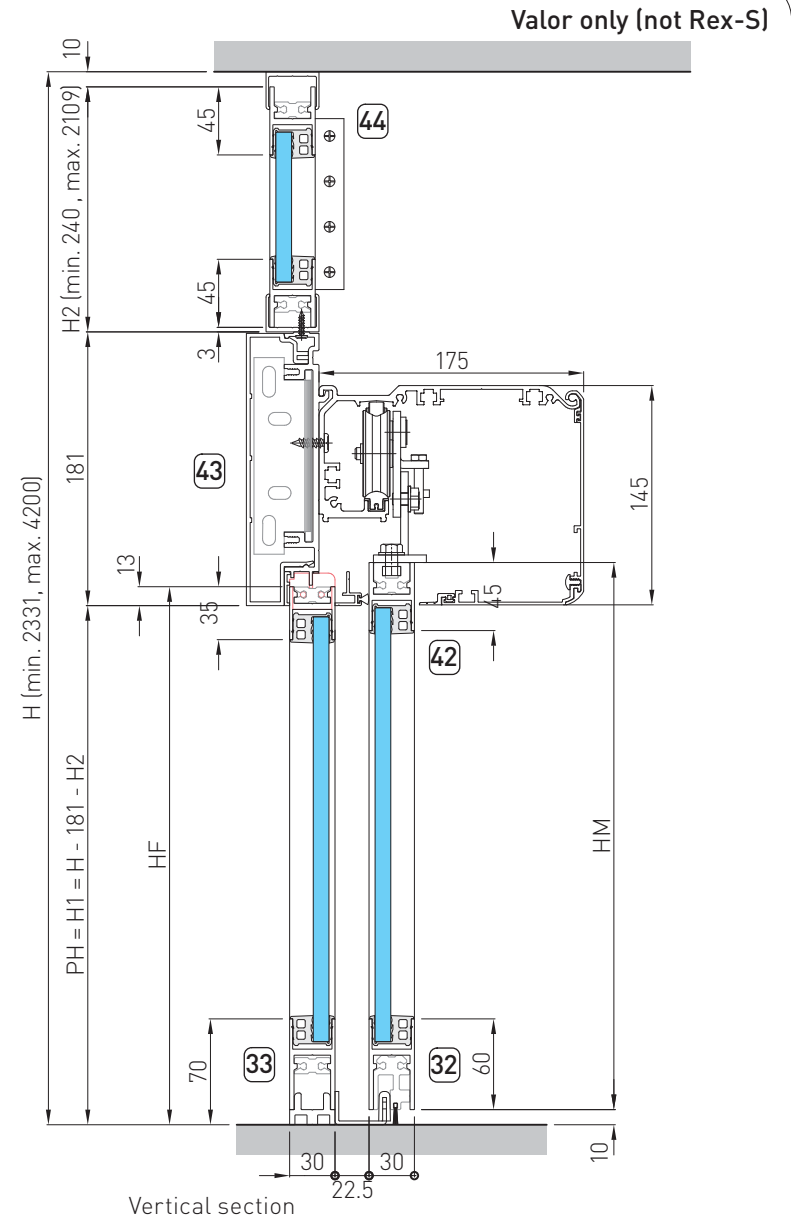

Vertical section

37. Vertical and horizontal section of 2 moving door wings (standard version)

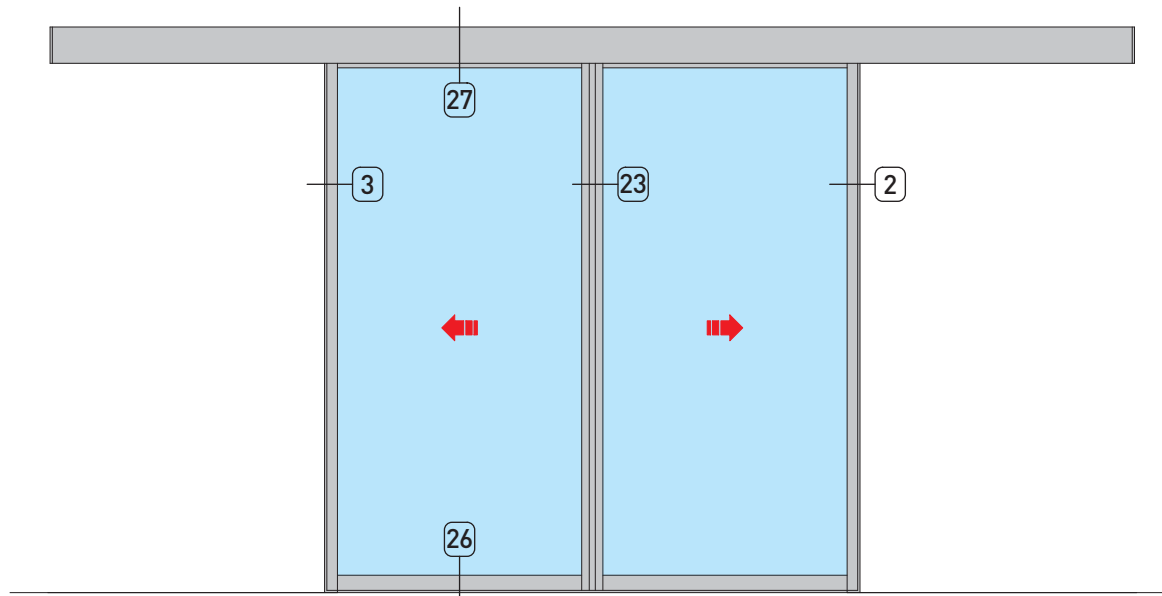

L (min. 800, max. 3000)

PL = L

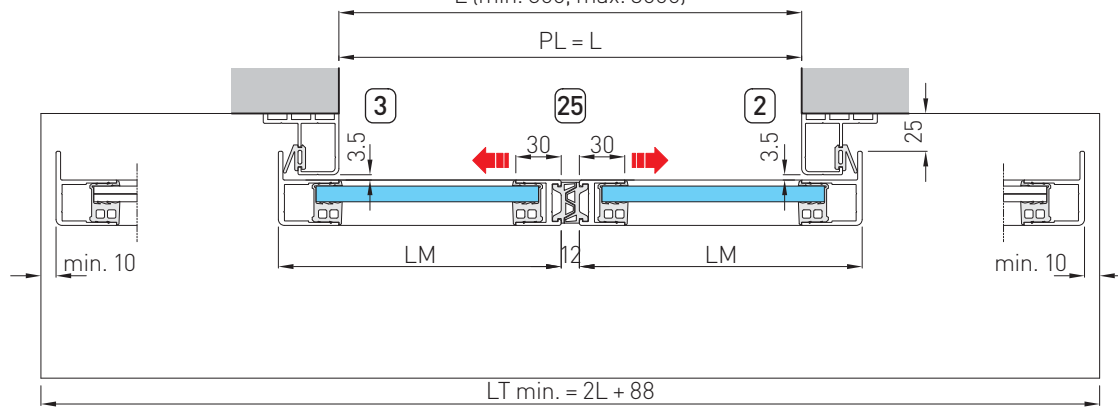

Horizontal section

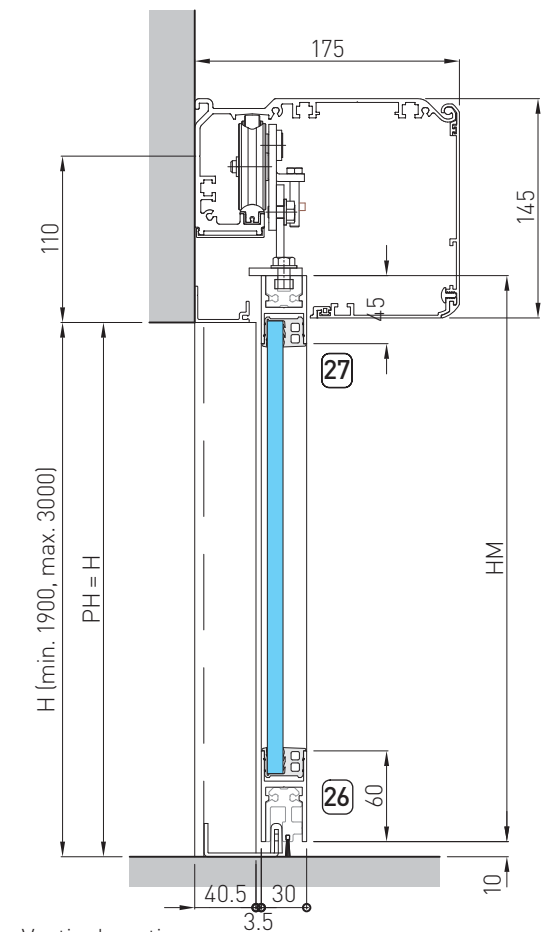

Vertical section

38. Vertical and horizontal section of 2 moving door wings (french version)

T43

Valor only (not Rex-S)

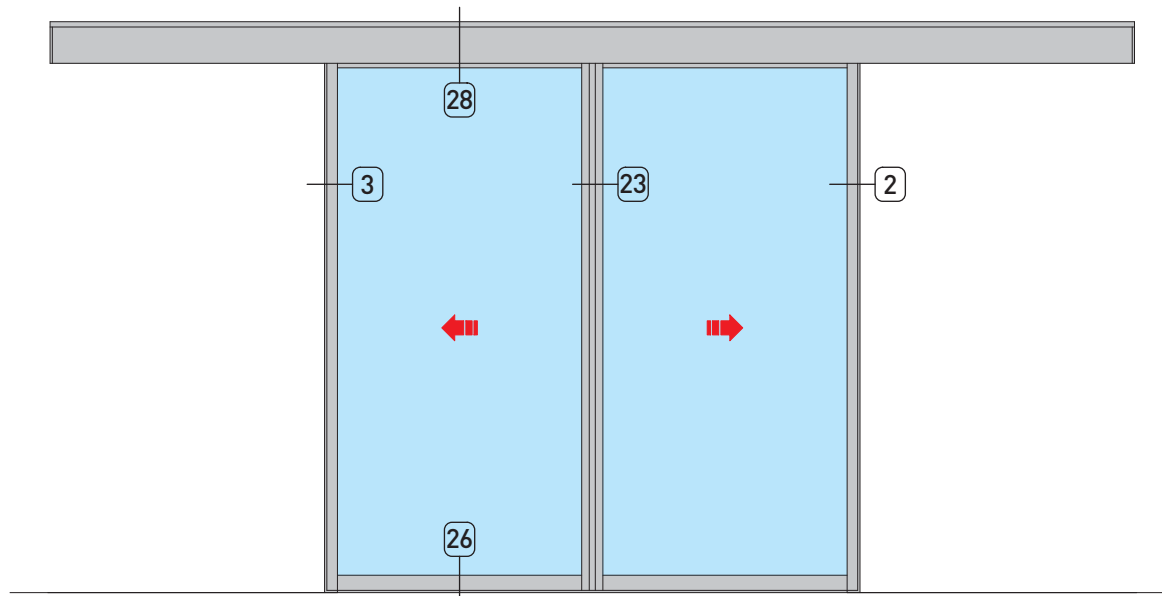

L (min. 800, max. 3000)

PL = L

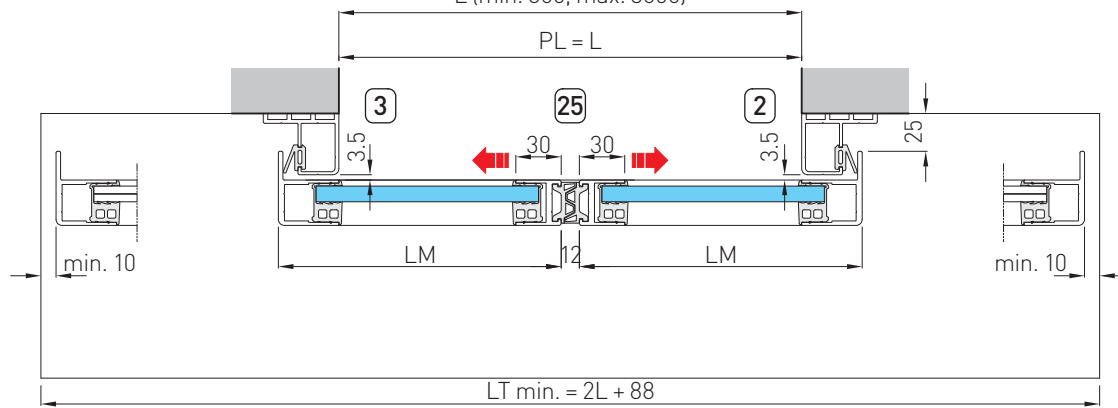

Horizontal section

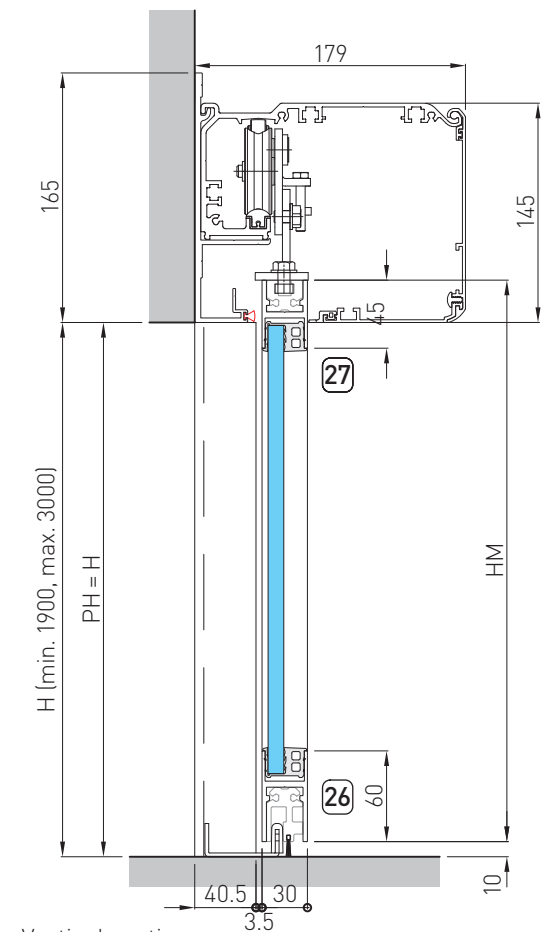

Vertical section

39. Vertical and horizontal section of 2 moving door wings with beam (standard version)

T44

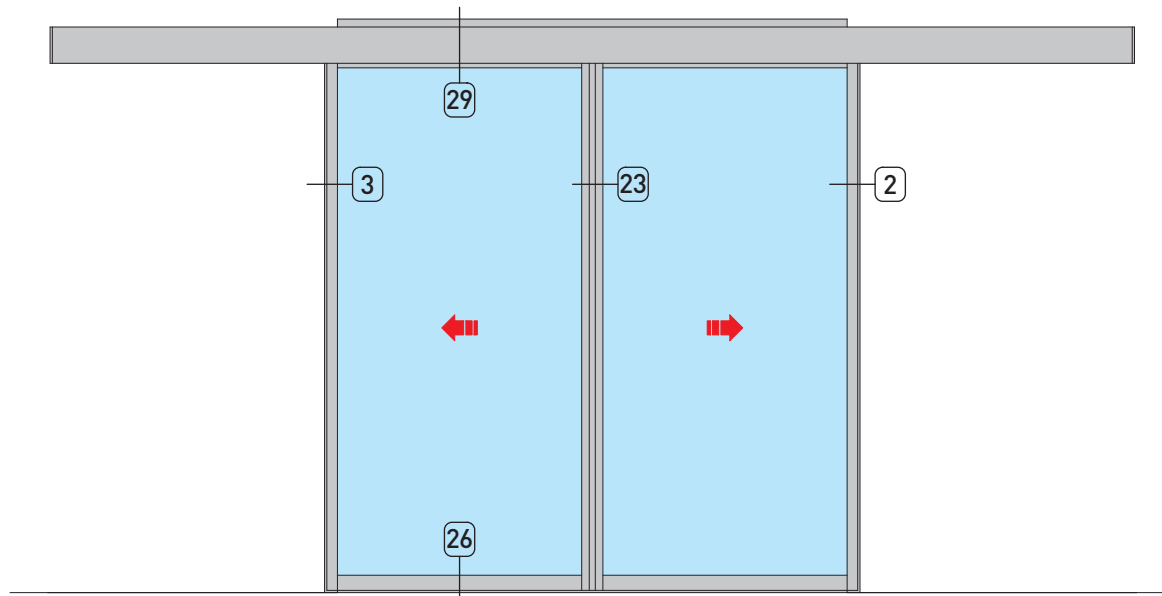

L (min. 800, max. 3000)

PL = L

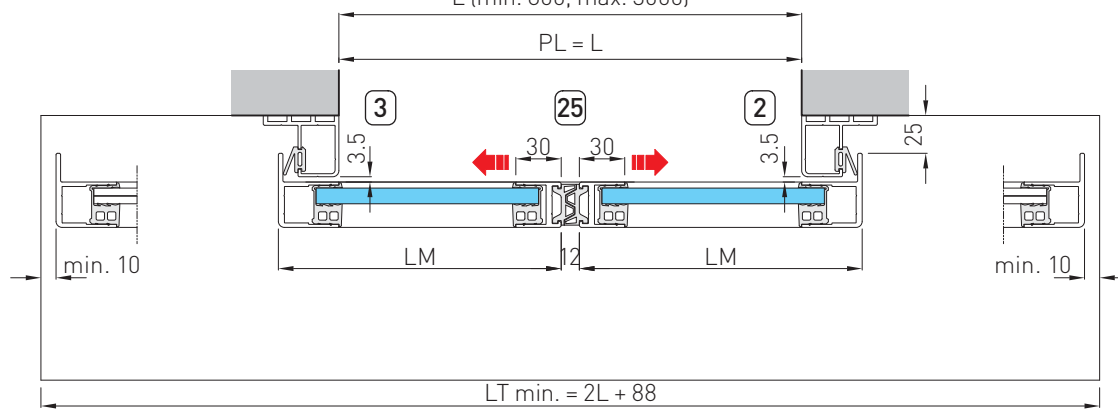

Horizontal section

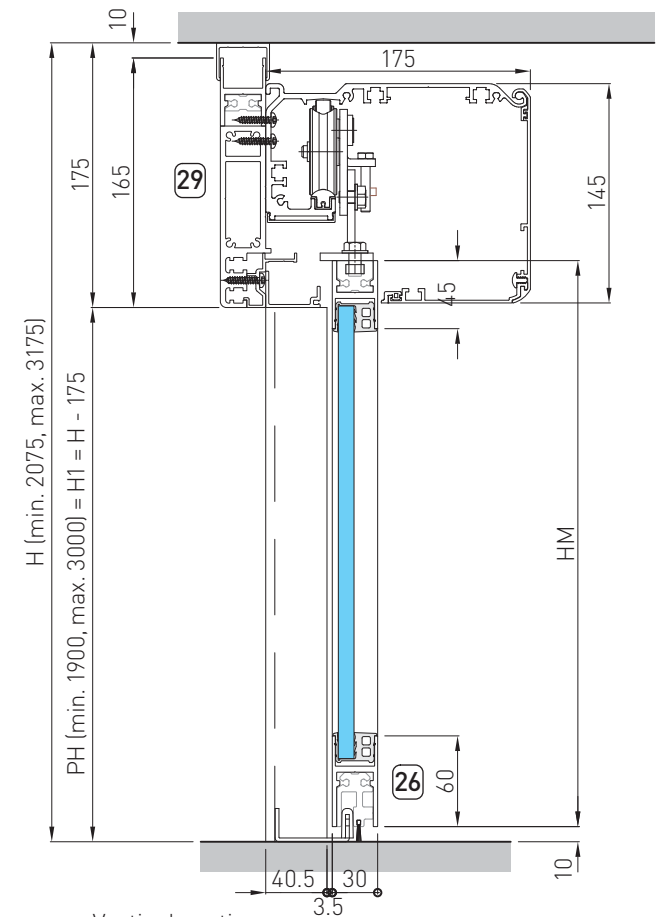

Vertical section

40. Vertical and horizontal section of 2 moving door wings with overhead (standard version)

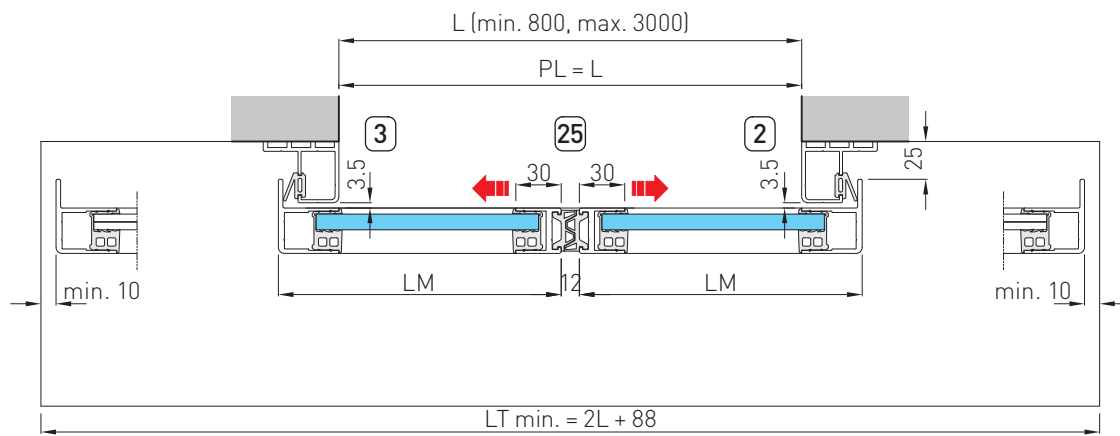
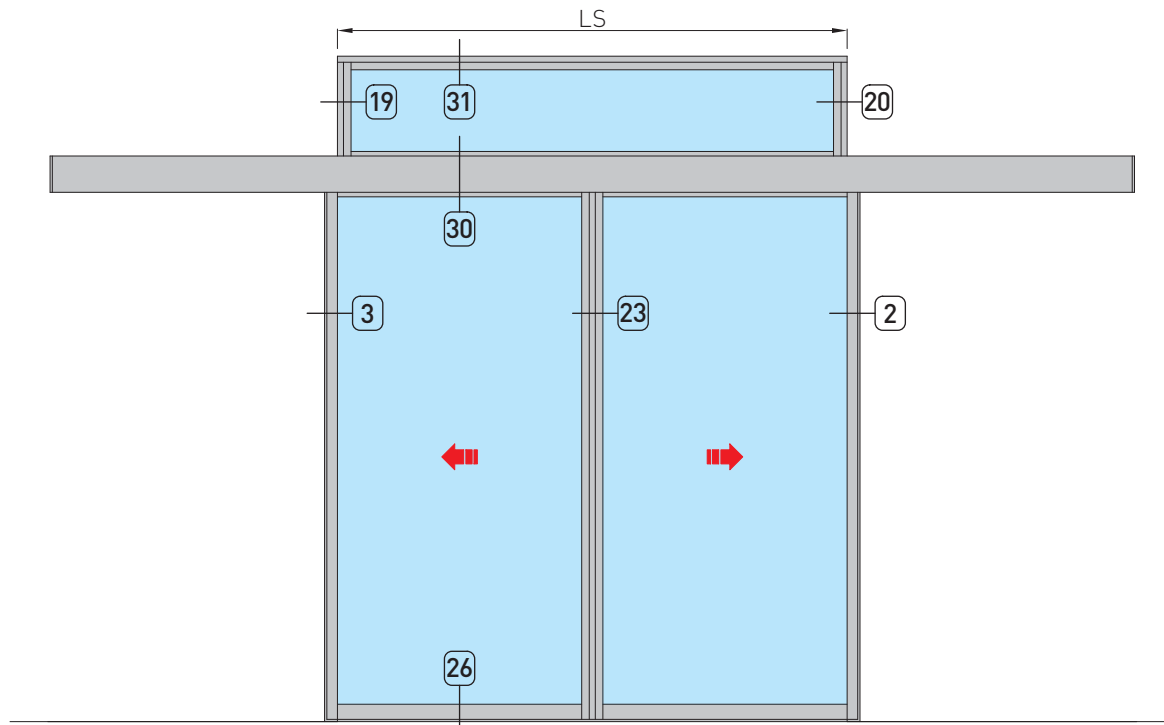

Horizontal section

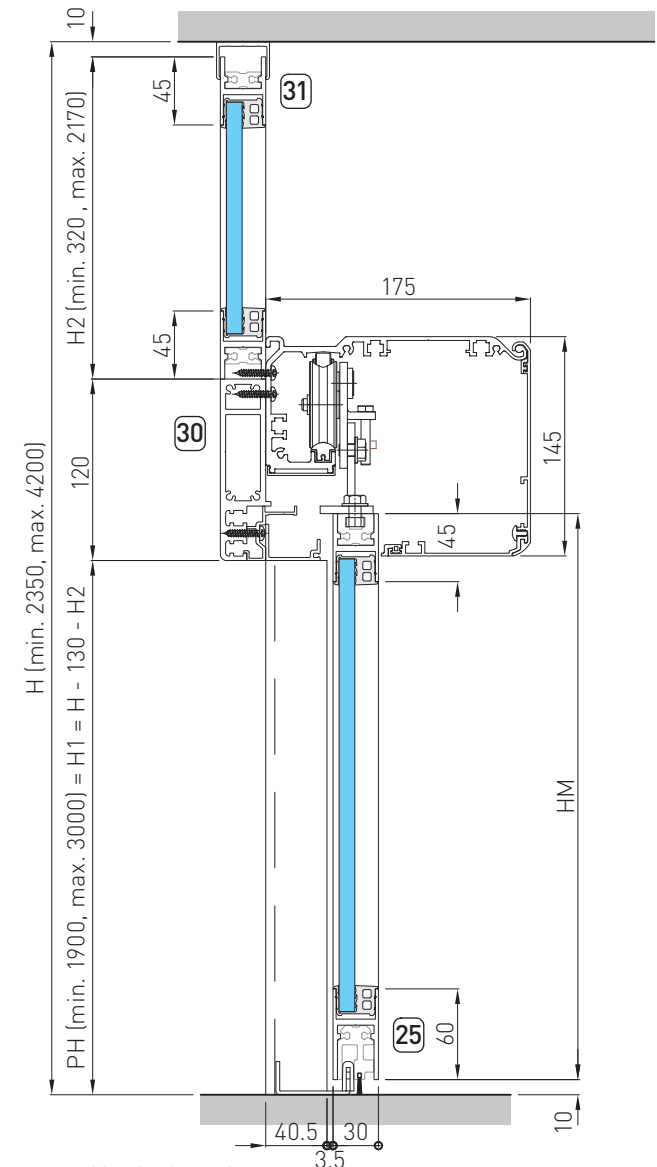

Vertical section

41. Vertical and horizontal section of 2 moving door wings and 2 fixed door wings with beam (standard version)

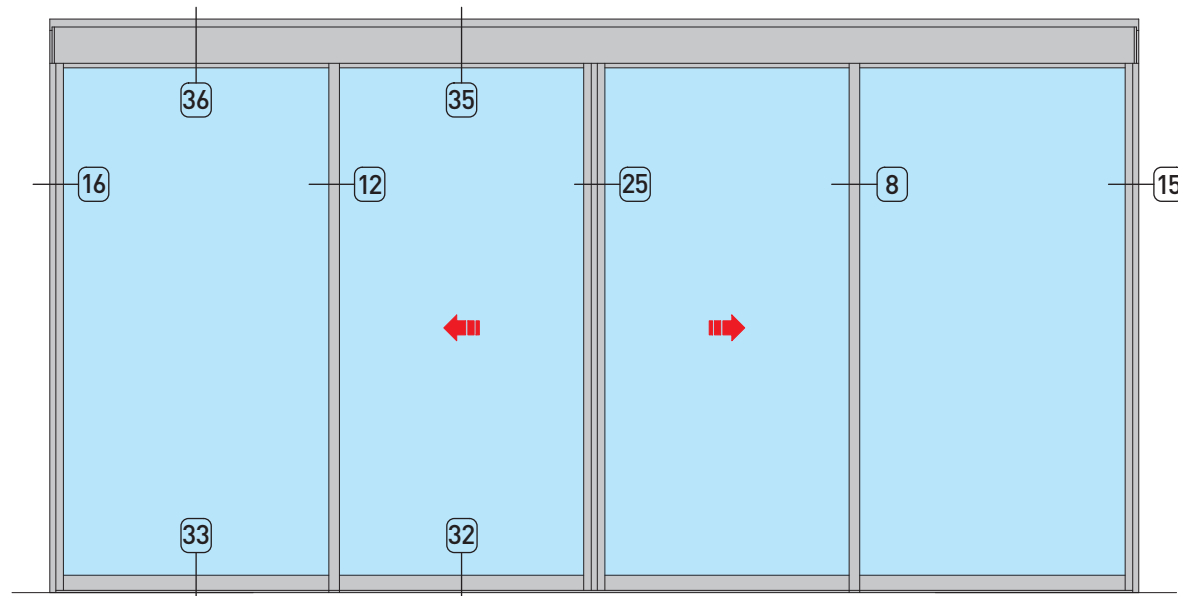

L (min. 1715, max. 6000)

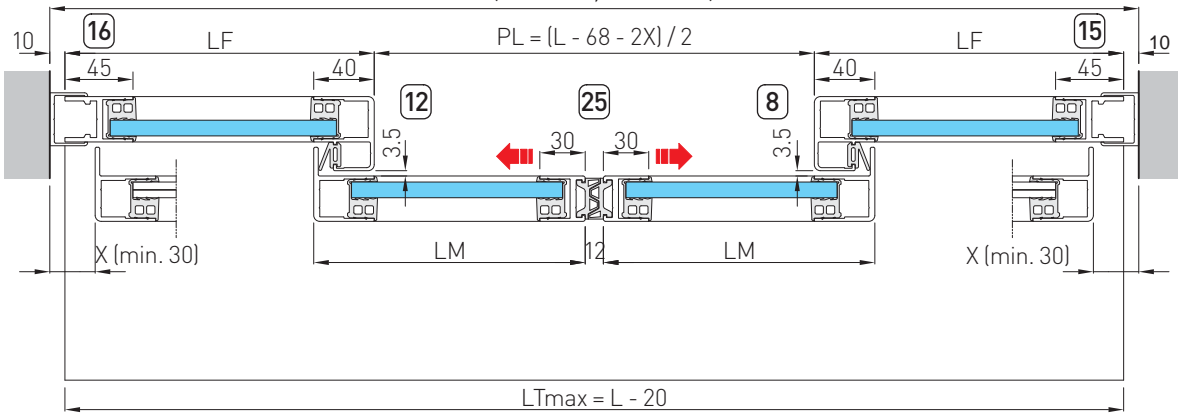

Horizontal section

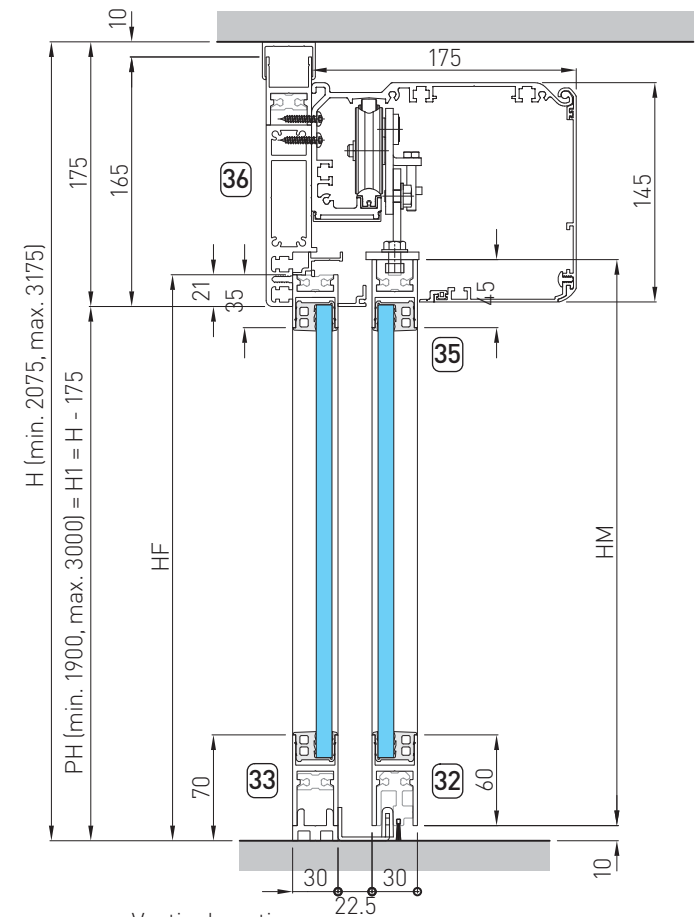

Vertical section

42. Vertical and horizontal section of 2 moving door wings and 2 fixed door wings (french version)

T47

Valor only (not Rex-S)

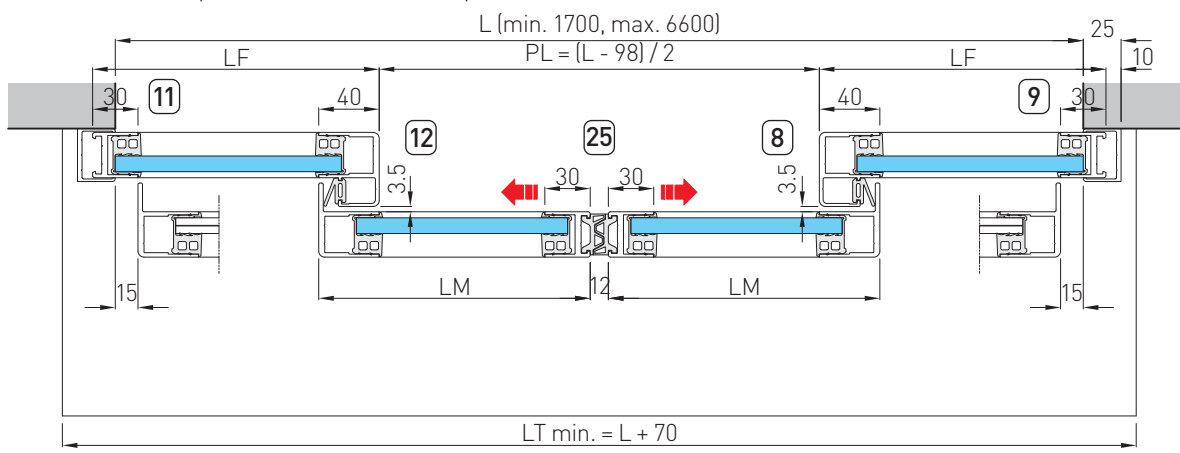
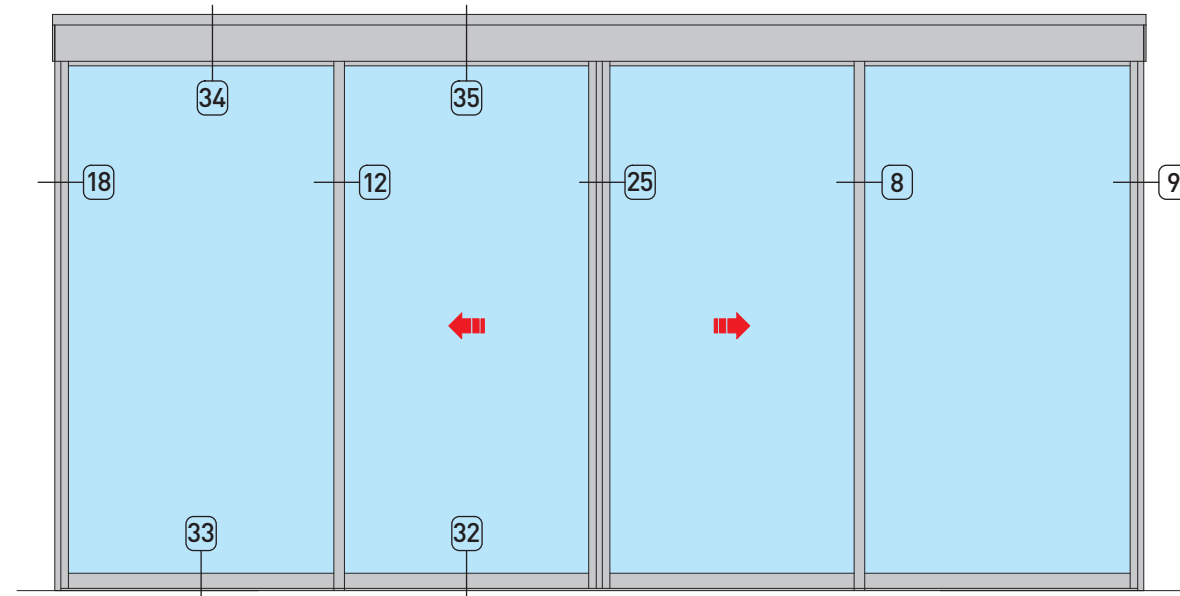

Horizontal section

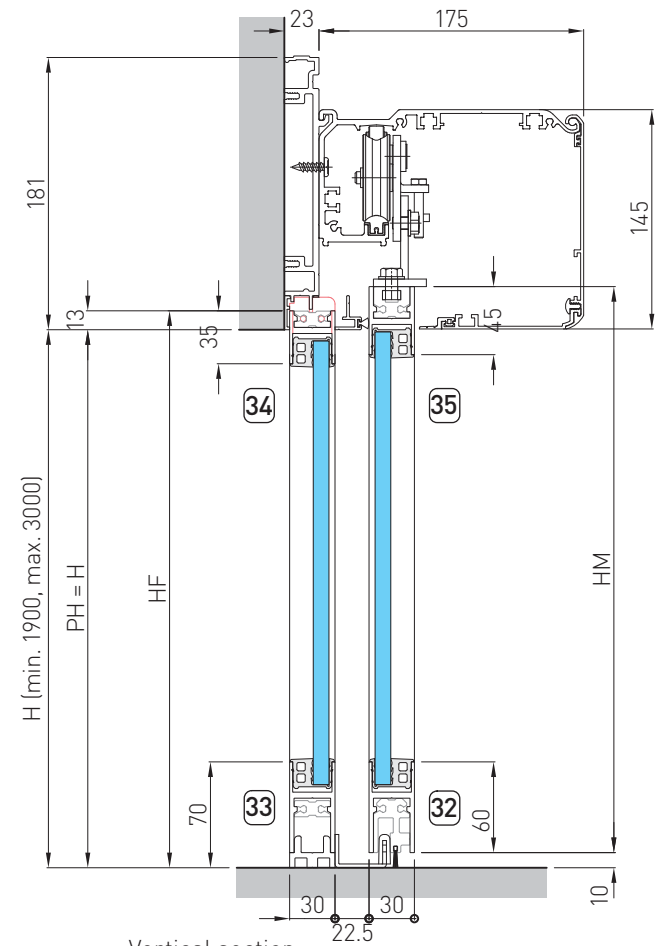

Vertical section

43. Vertical and horizontal section of 2 moving door wings and 2 fixed door wings with beam (french version)

Valor only (not Rex-S)

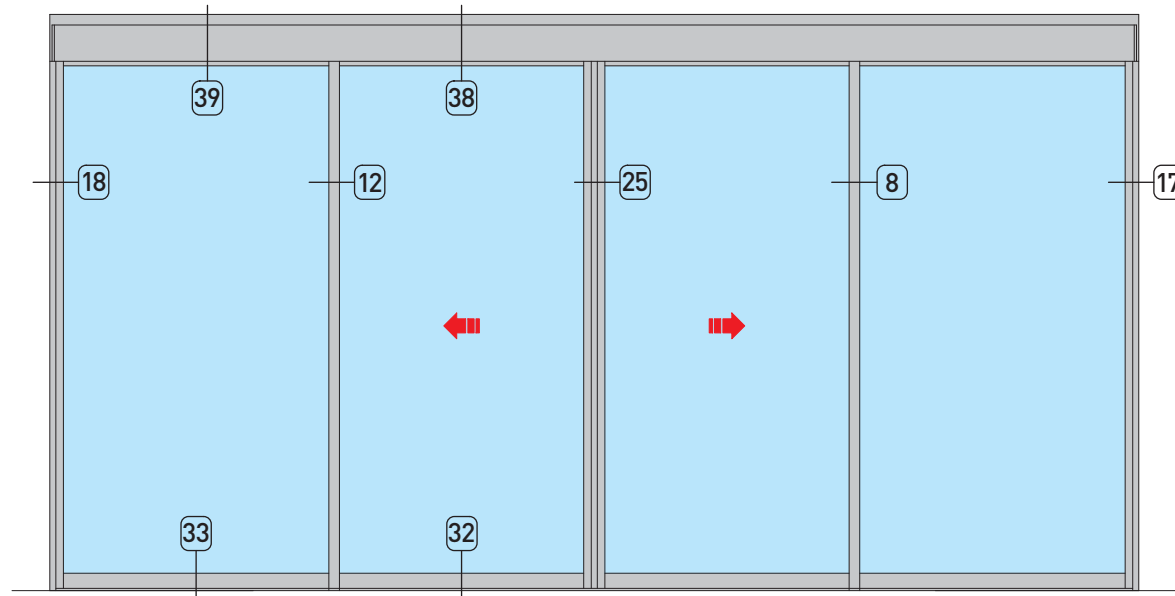

L (min. 1700, max. 6600)

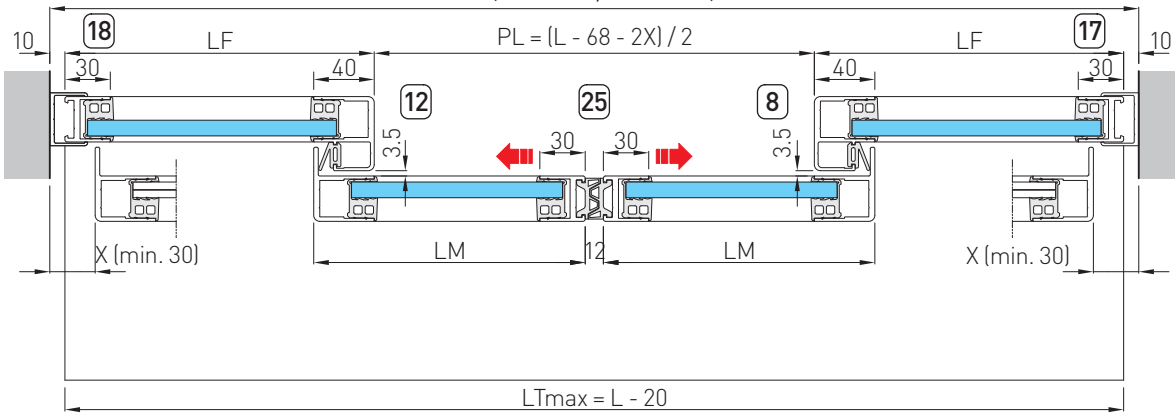

Horizontal section

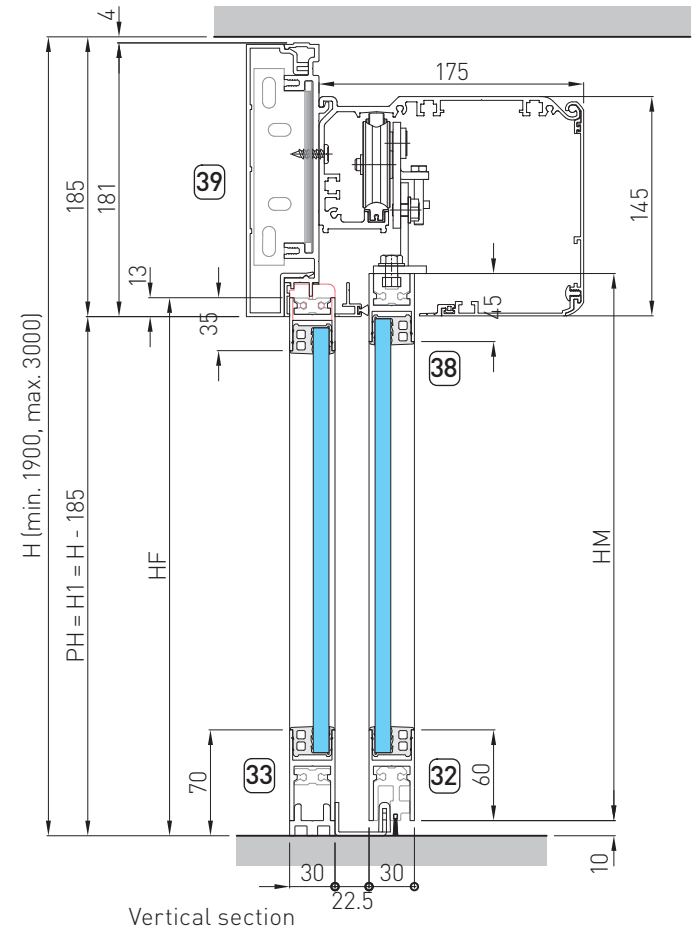

Vertical section

44. Vertical and horizontal section of 2 moving door wings and 2 fixed door wings with overlight (standard version)

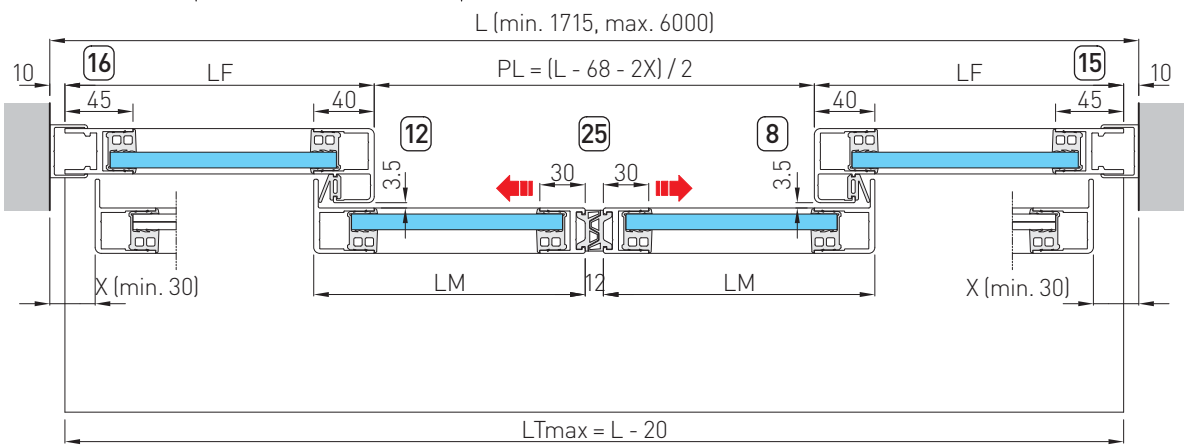
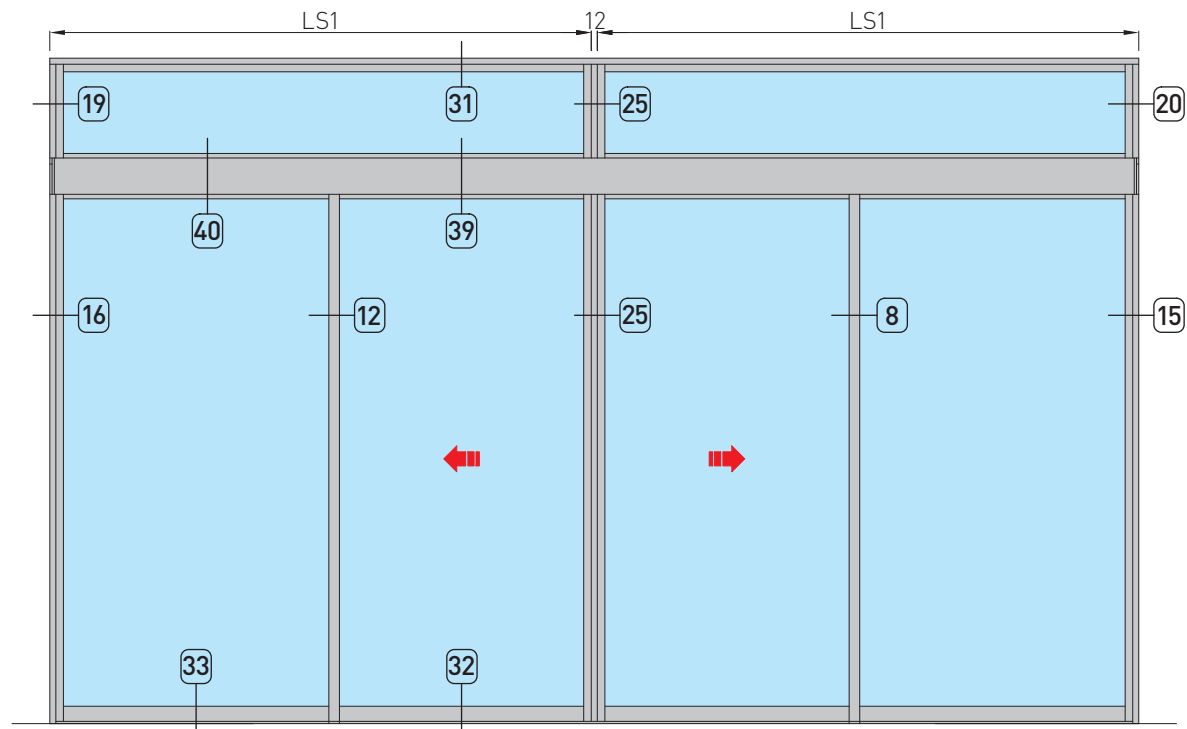

Horizontal section

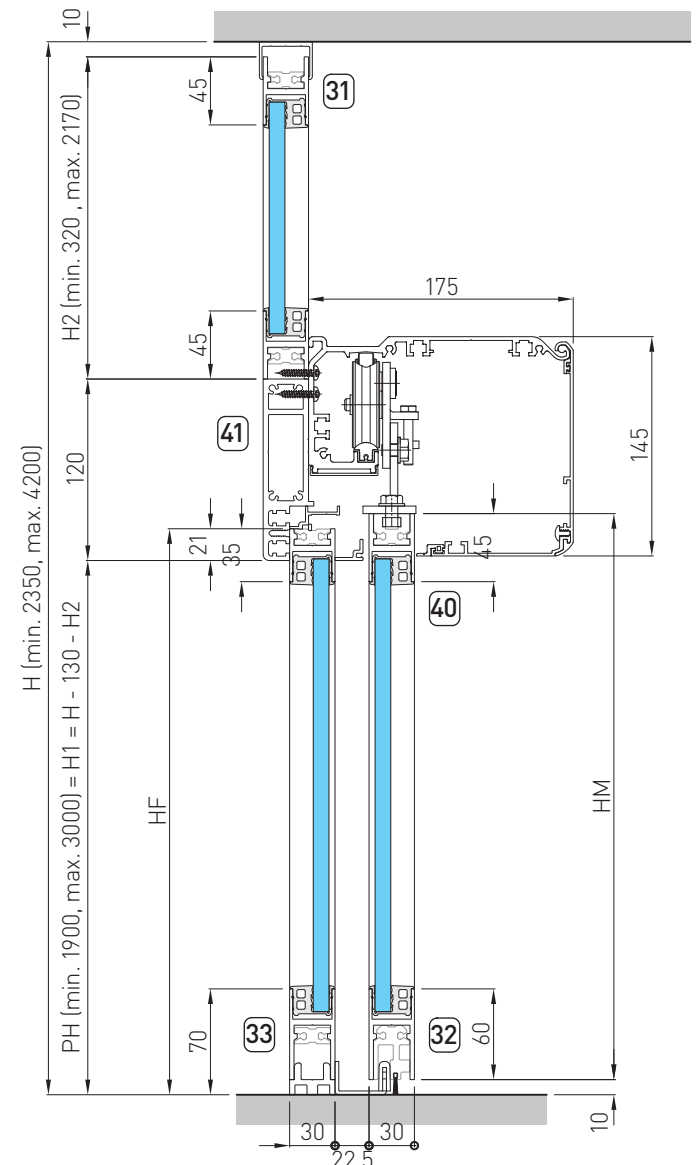

Vertical section

45. Vertical and horizontal section of 2 moving door wings and 2 fixed door wings with overhead (french version)

T50

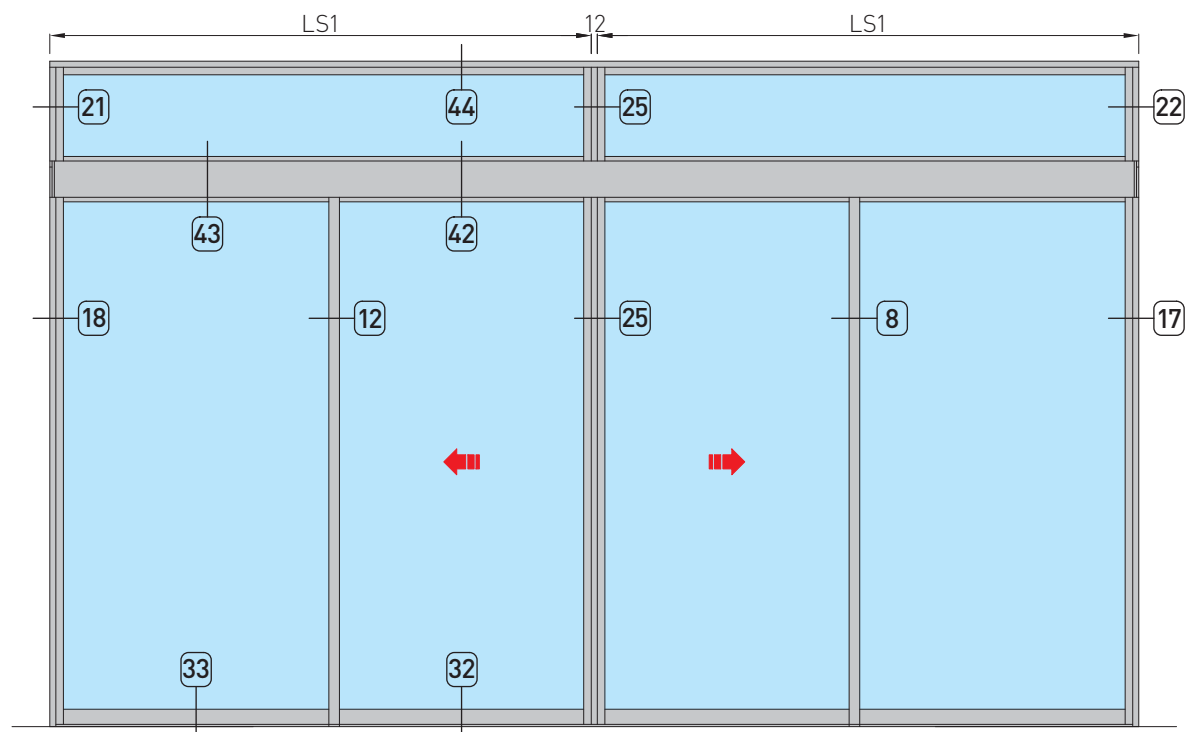

L (min. 1700, max. 6600)

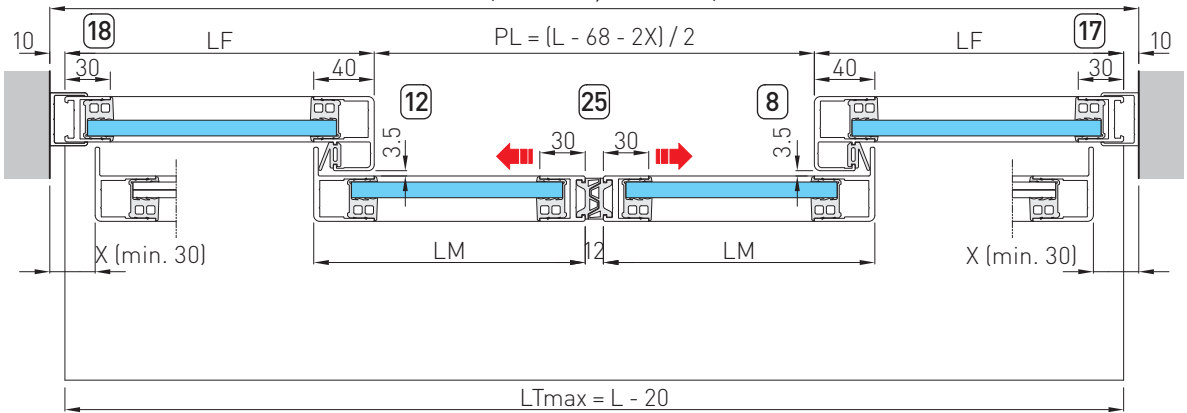

Horizontal section

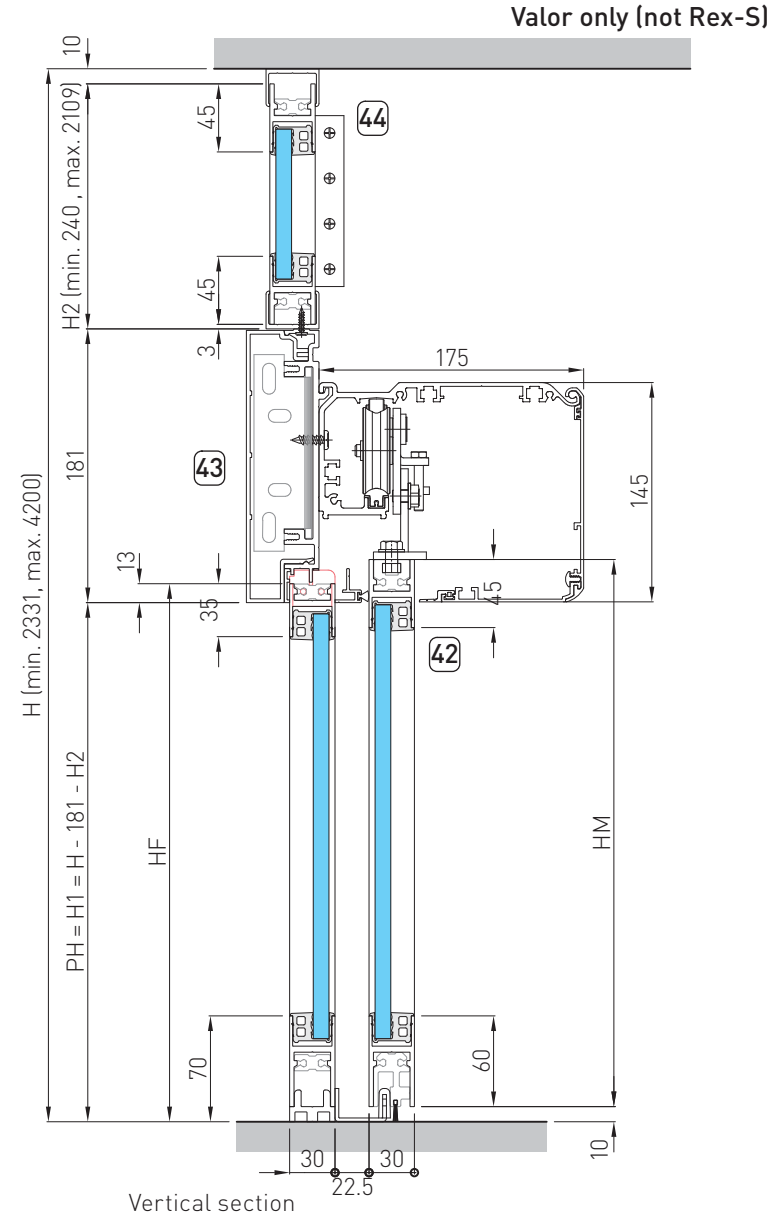

Vertical section

1

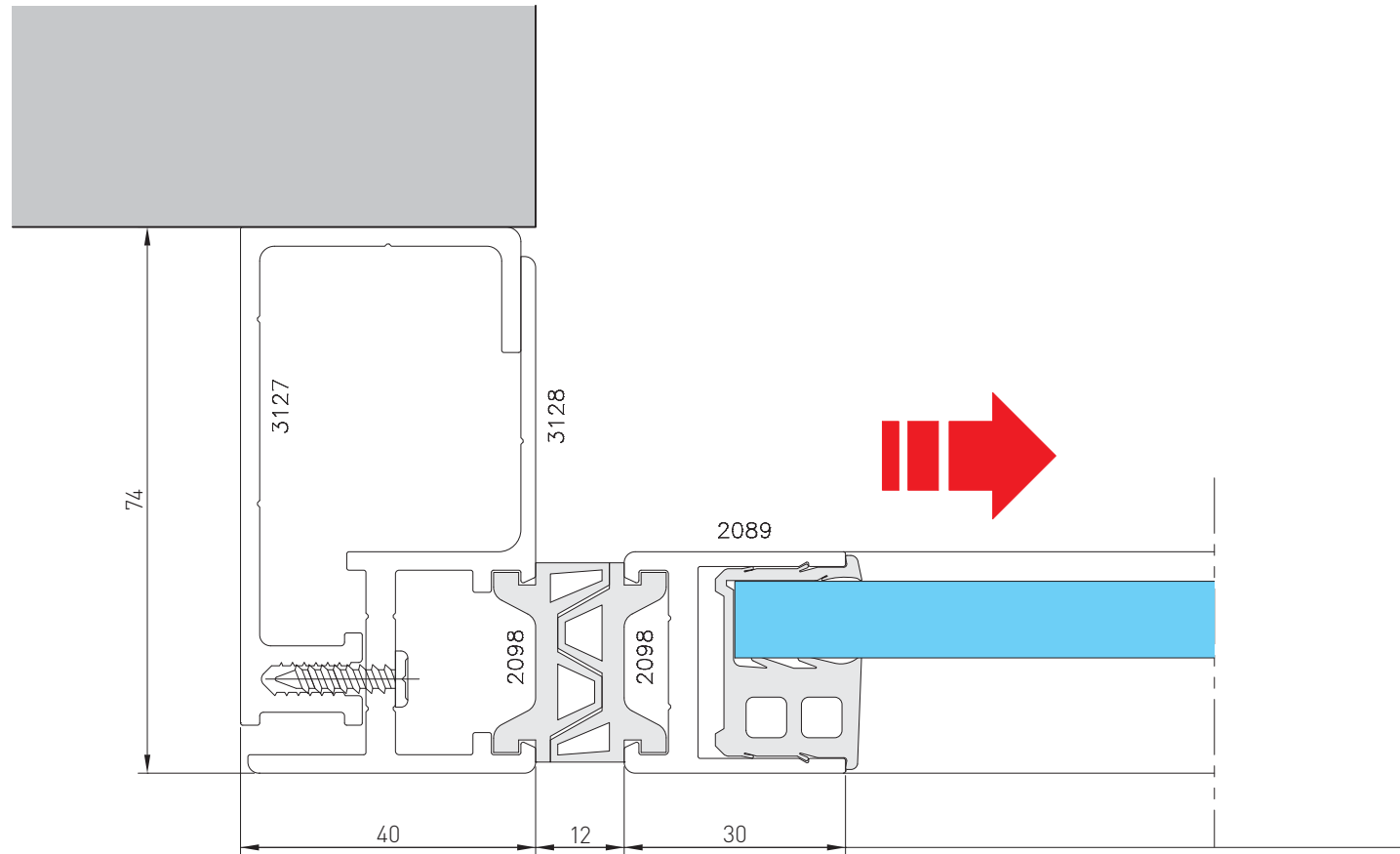

2

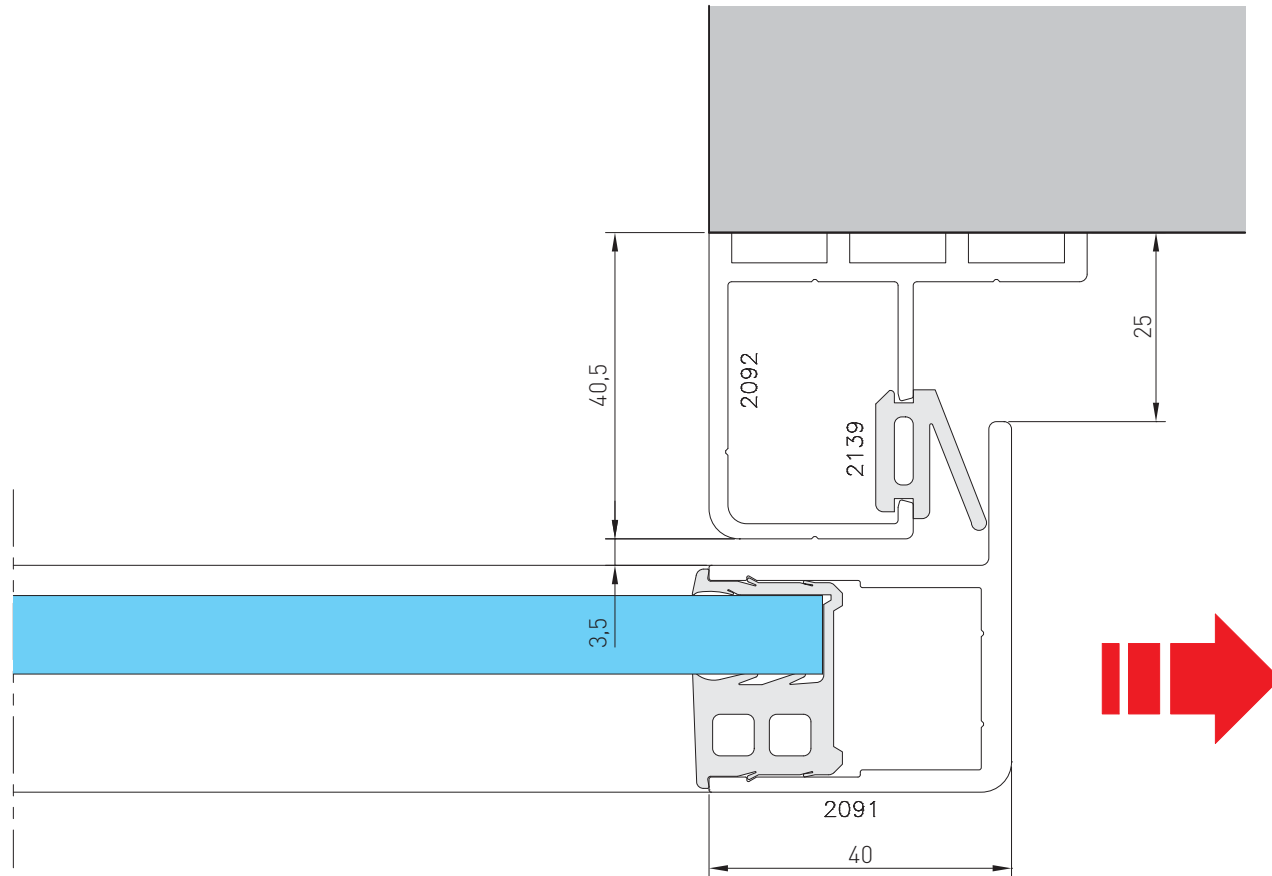

3

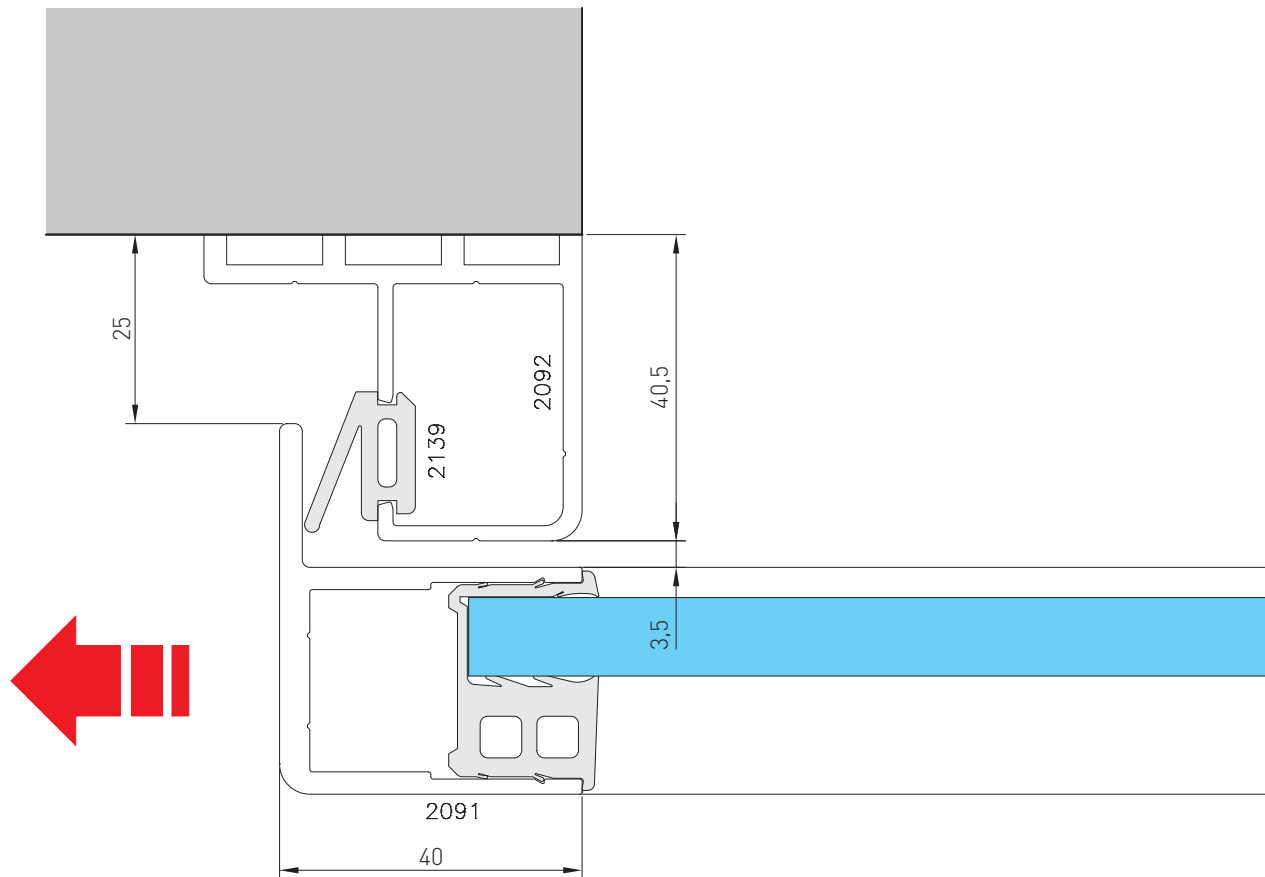

4

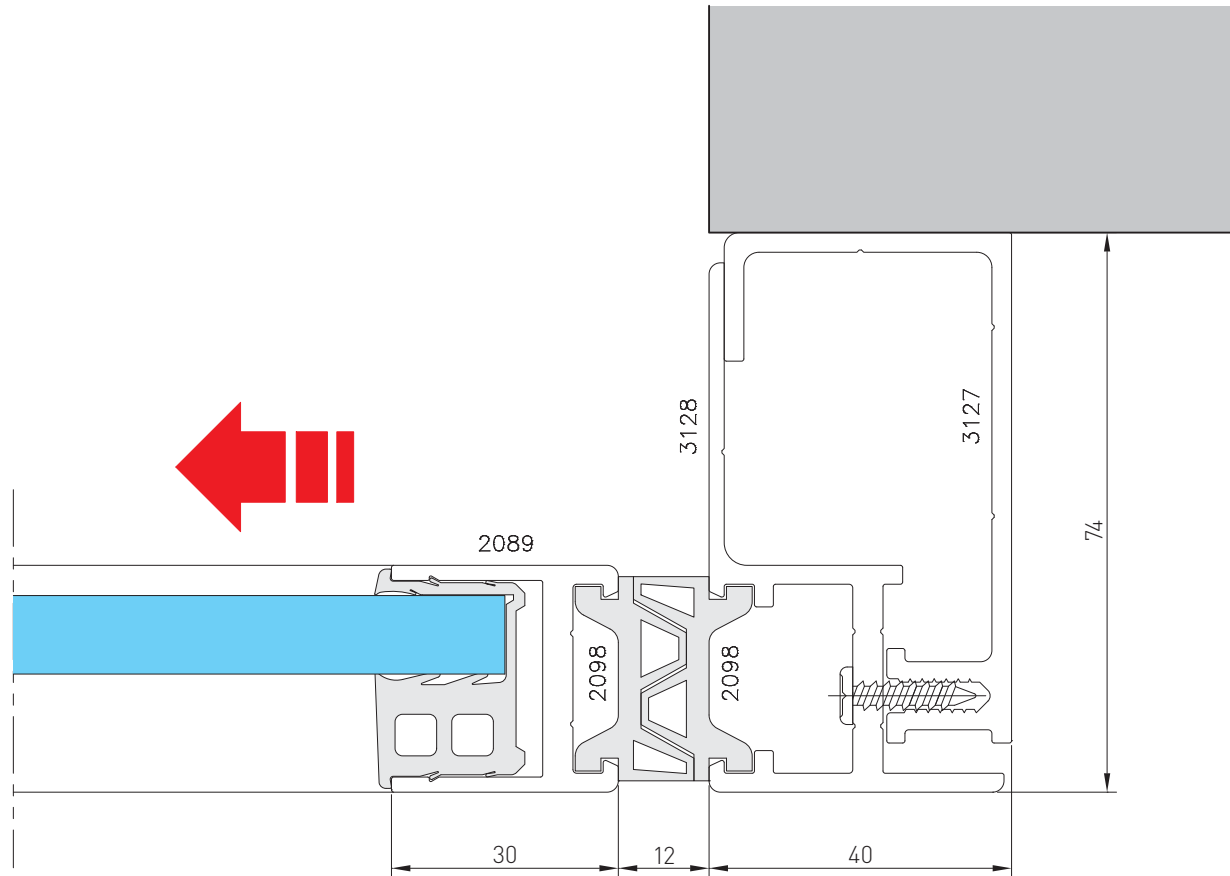

5

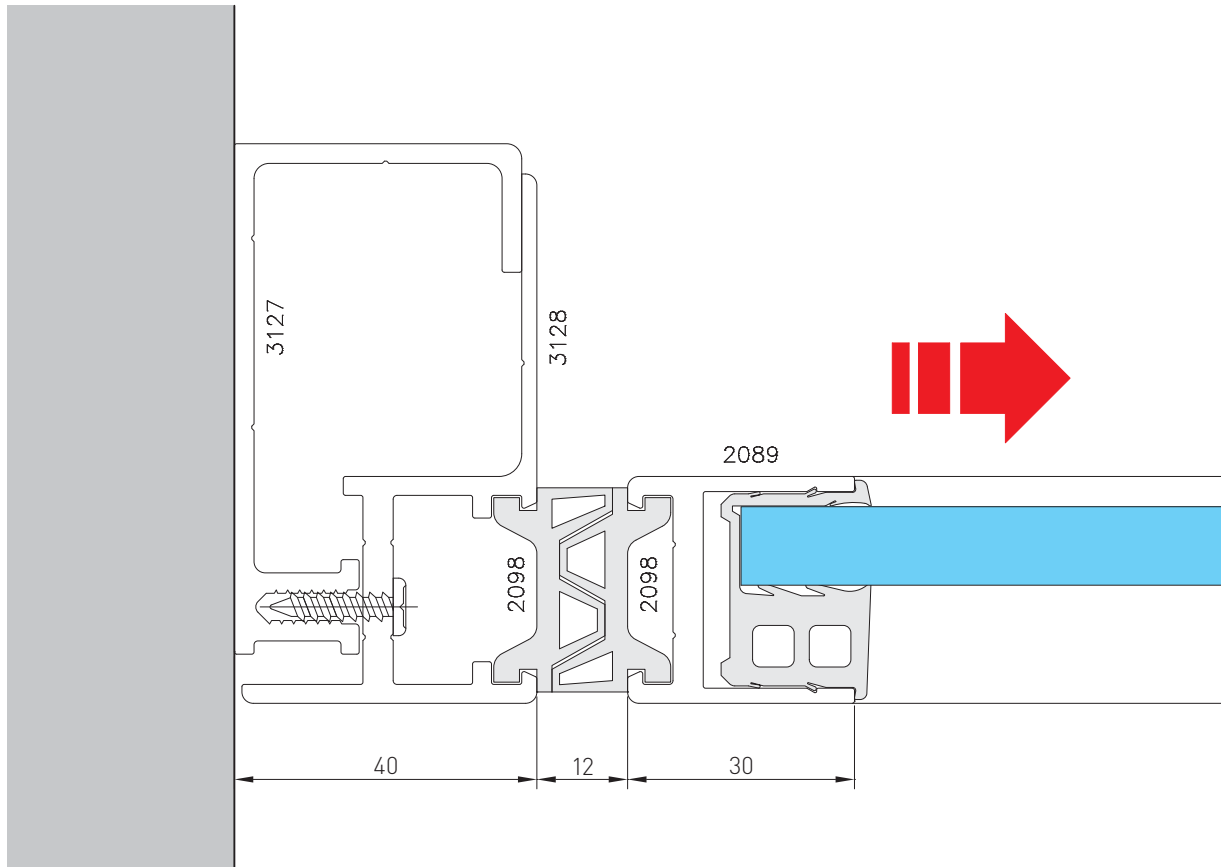

6

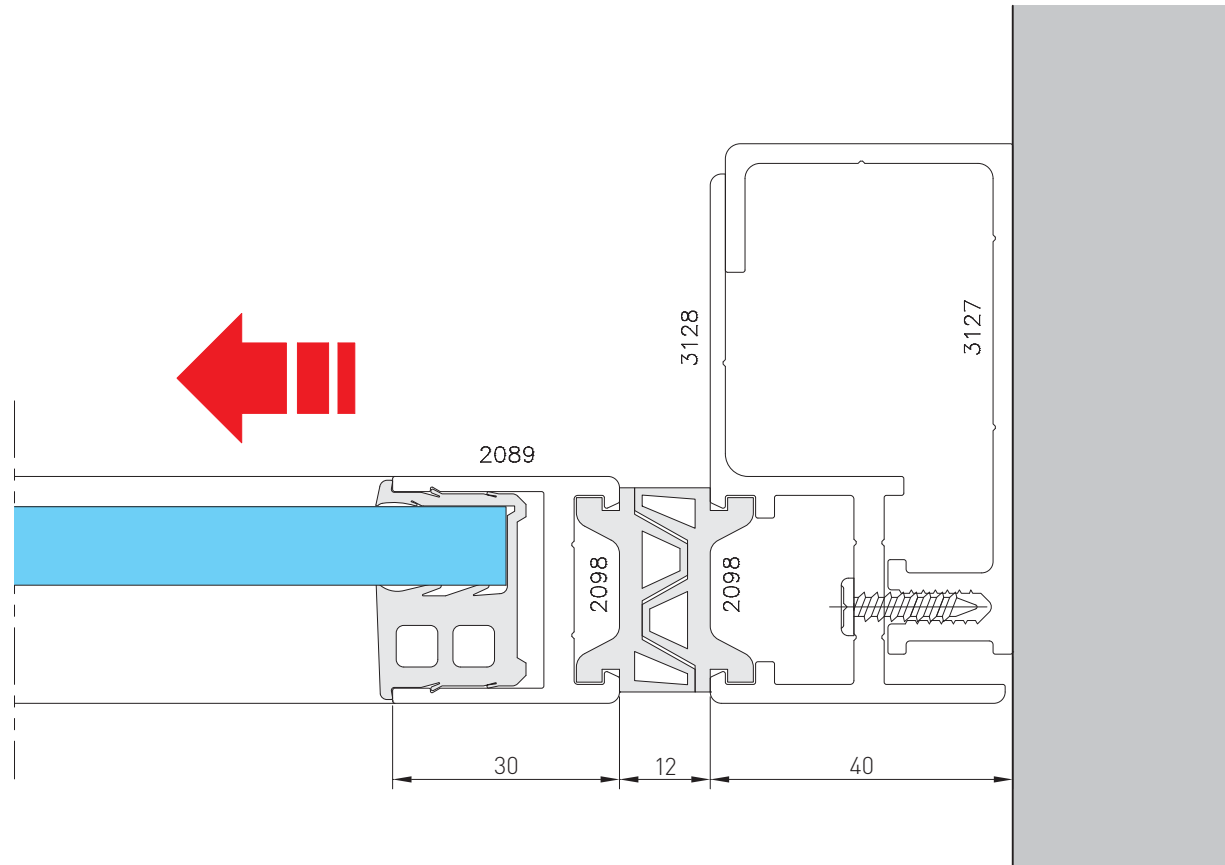

7

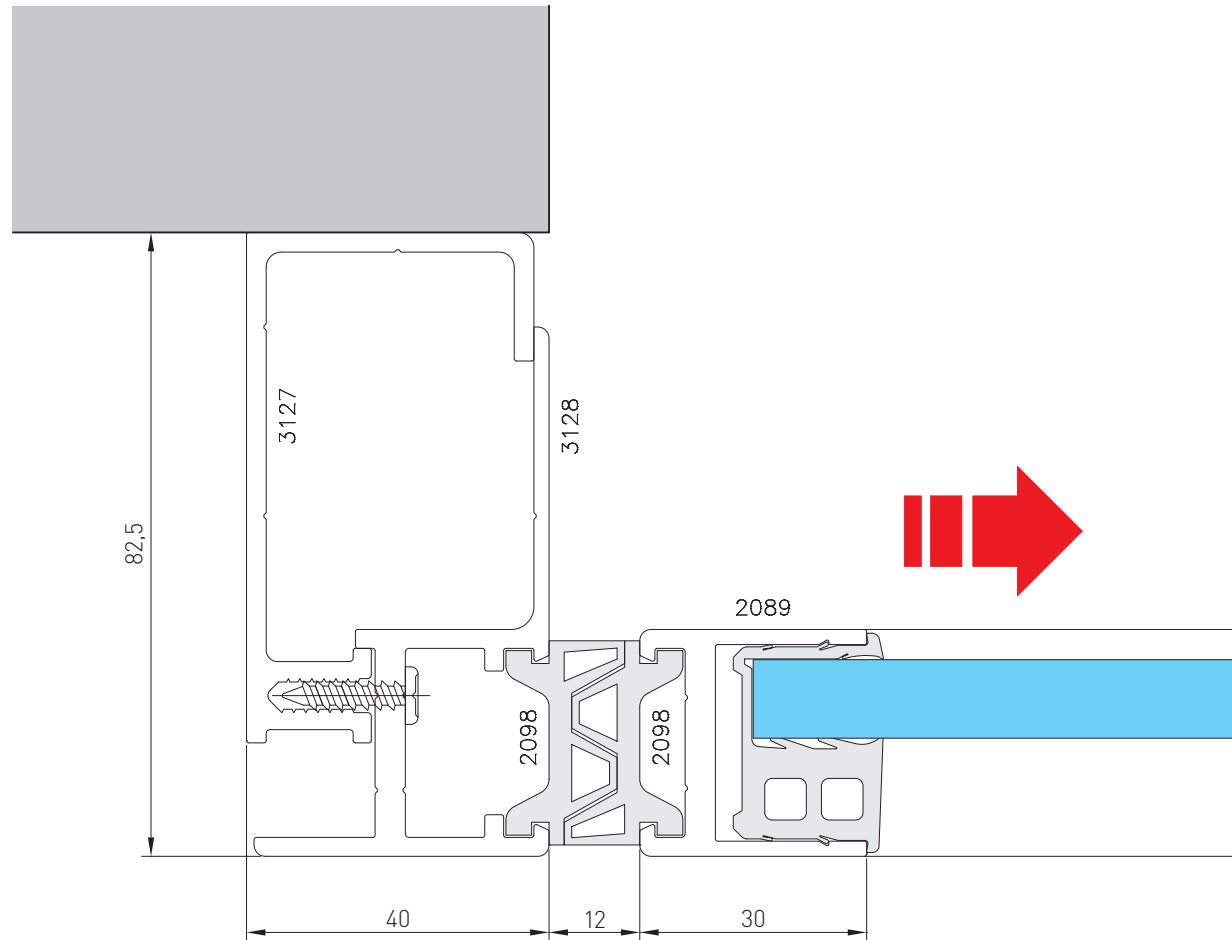

8

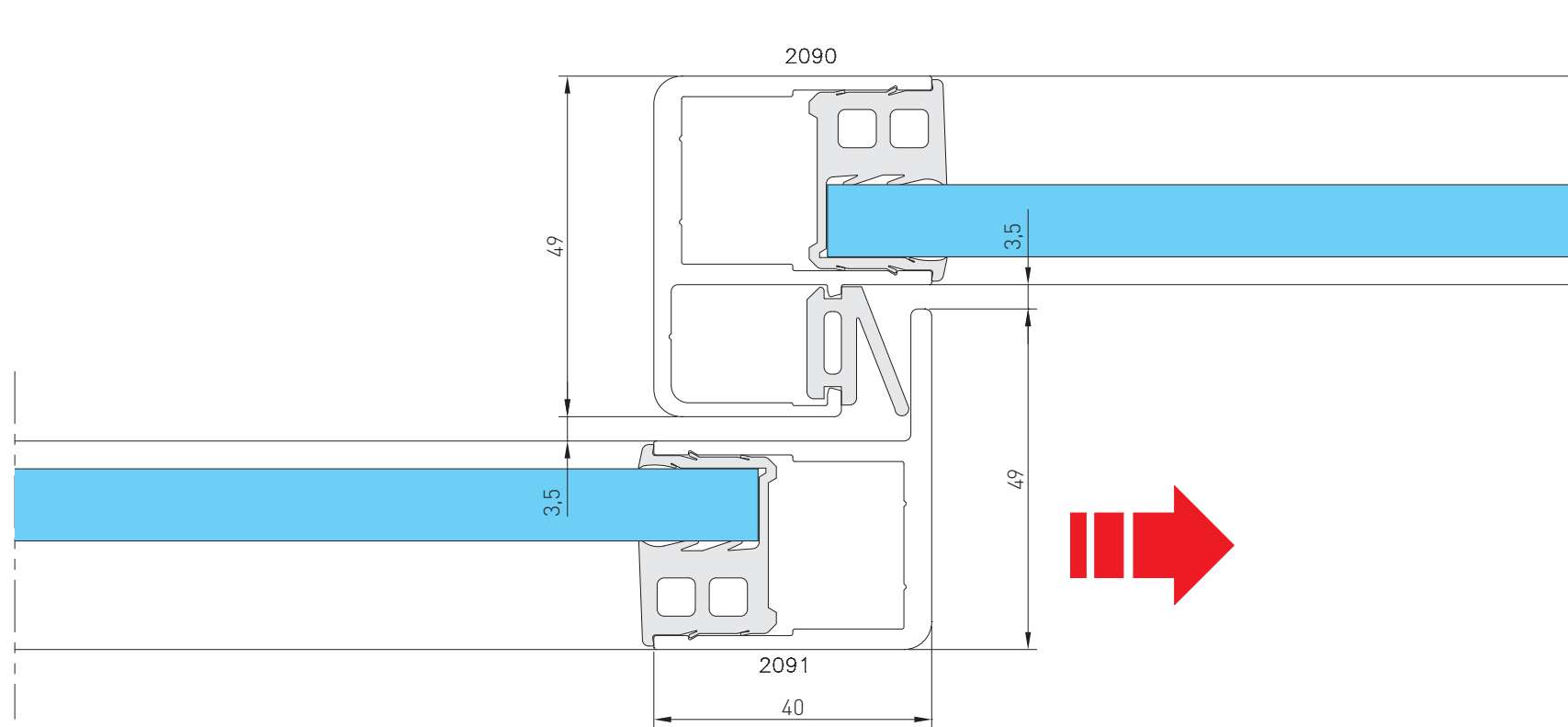

9

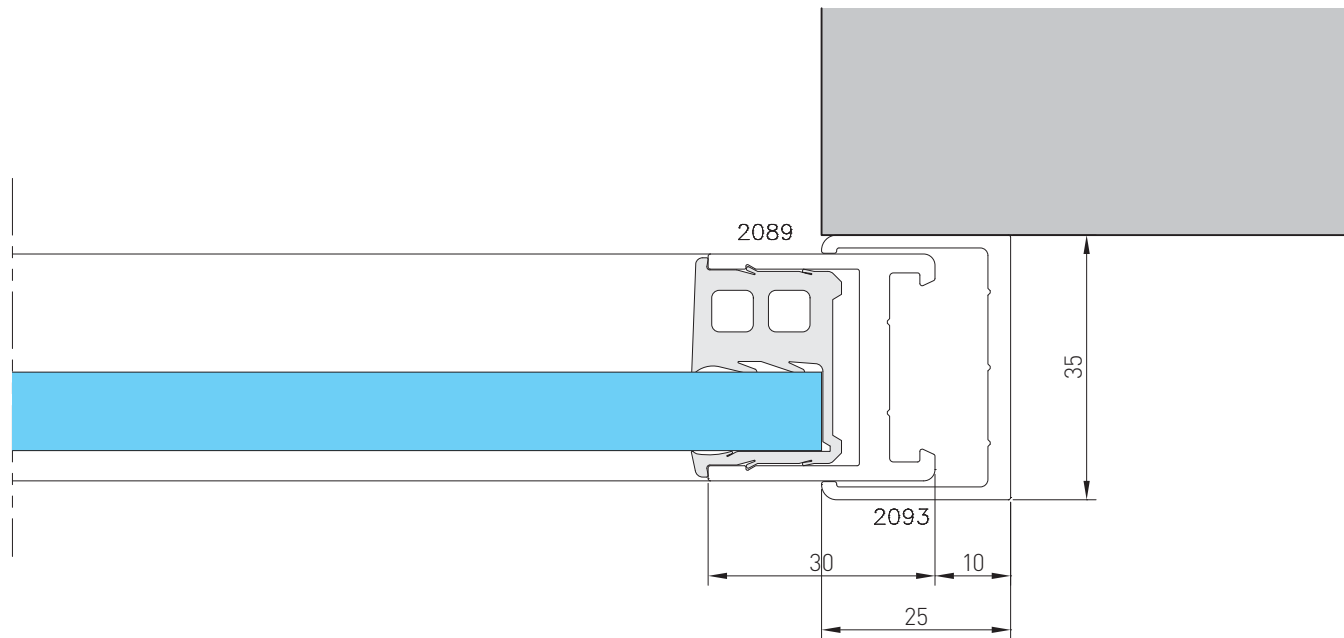

10

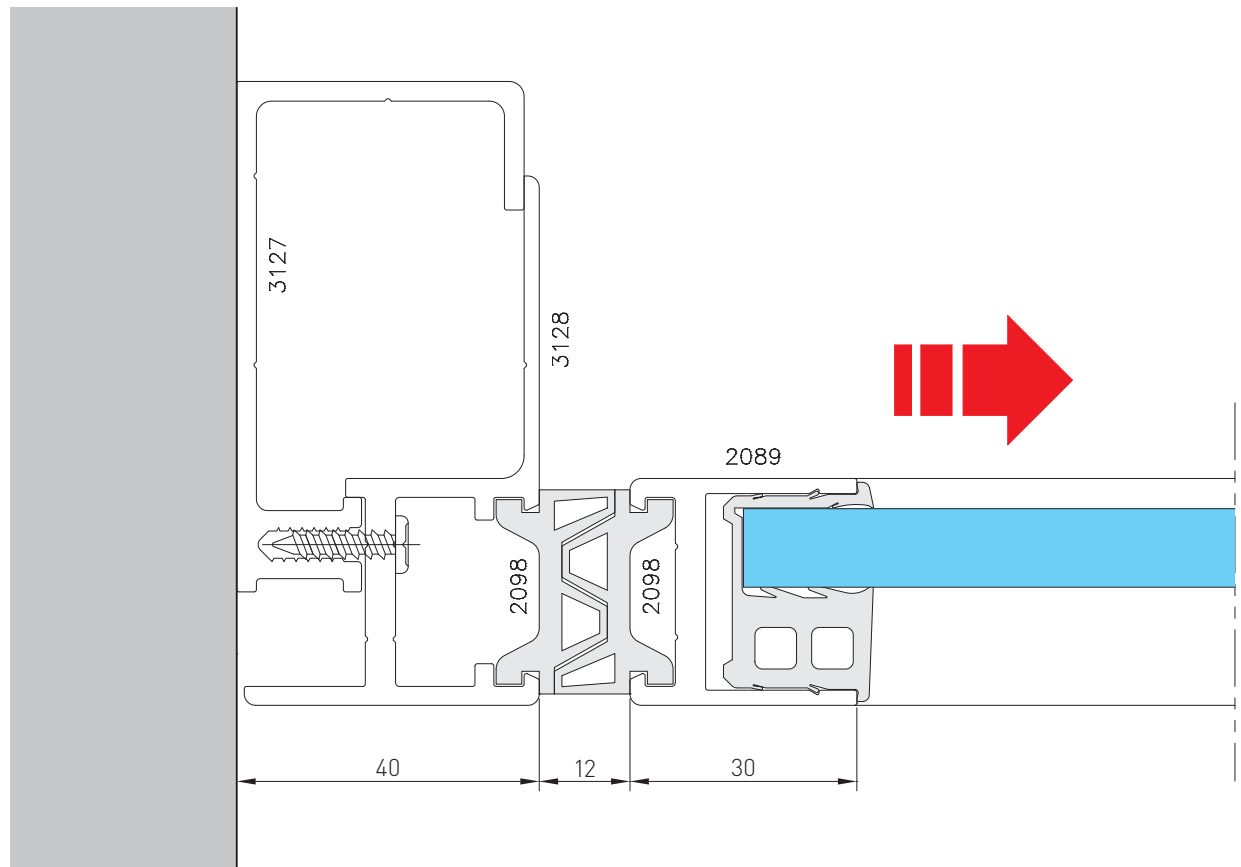

11

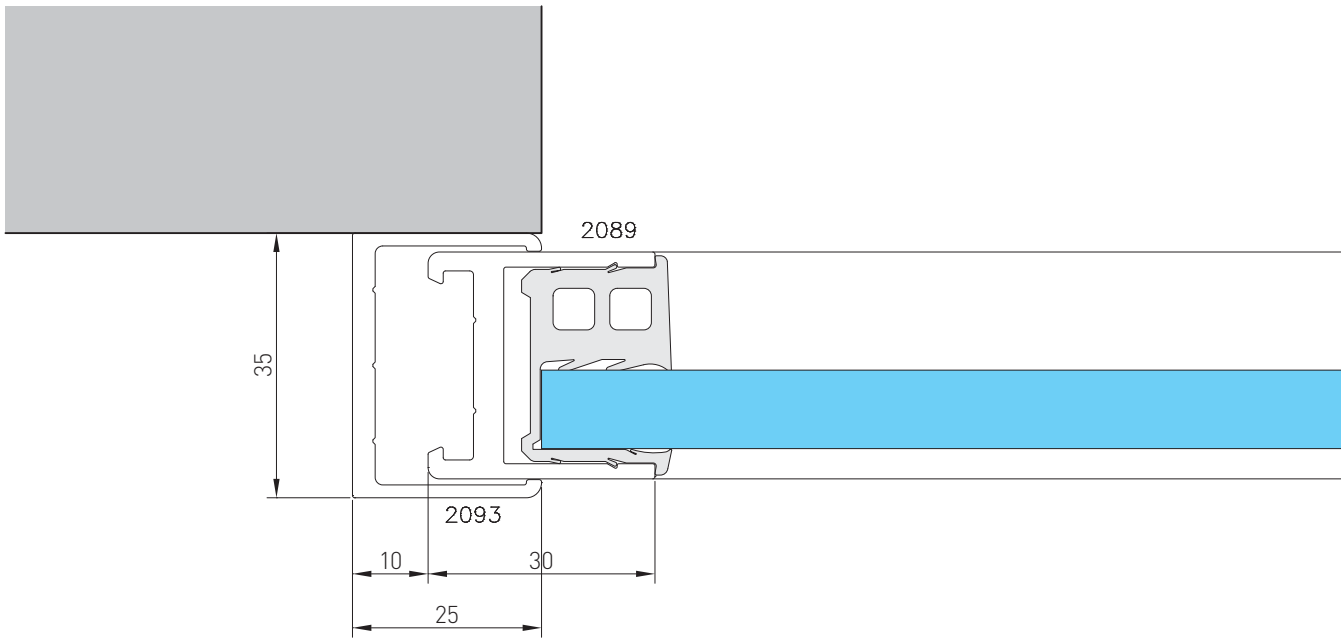

12

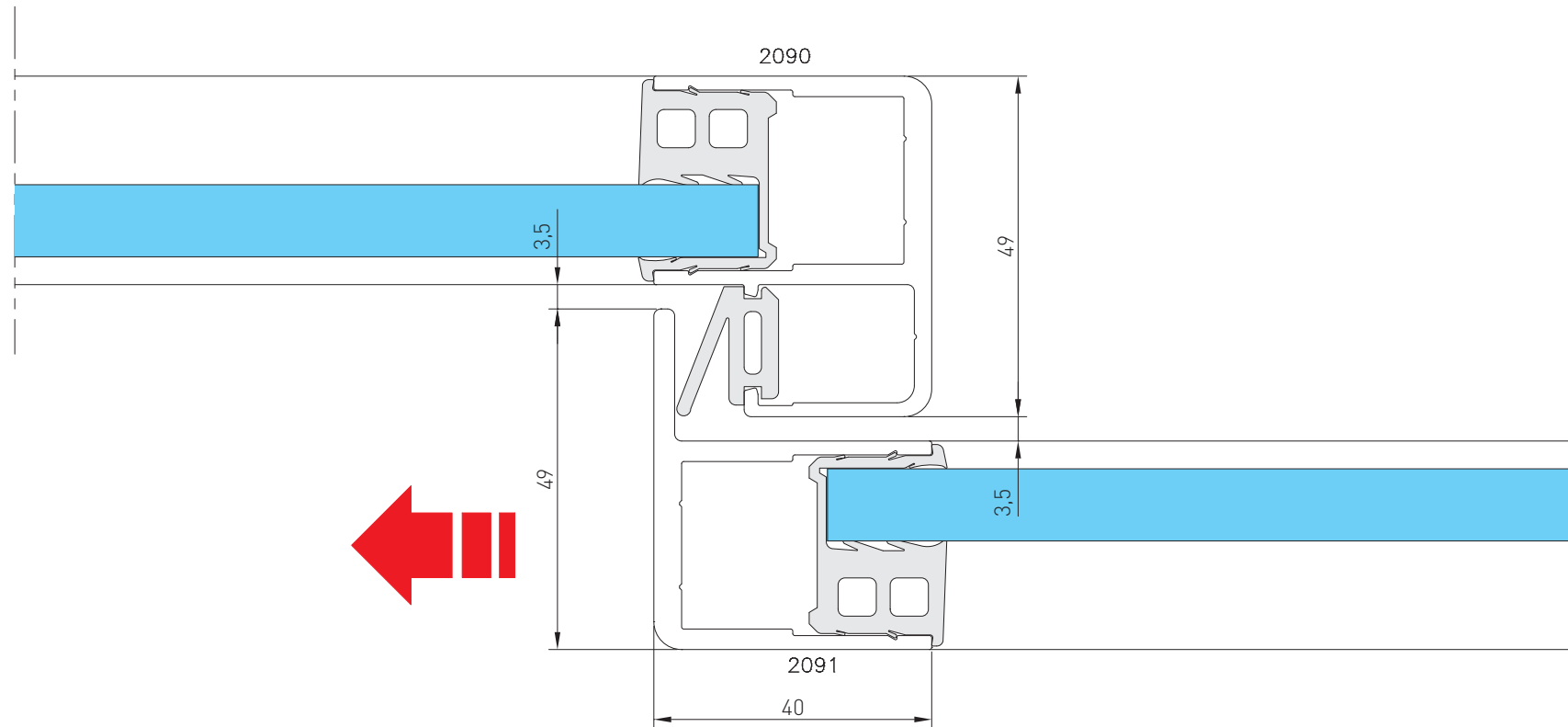

13

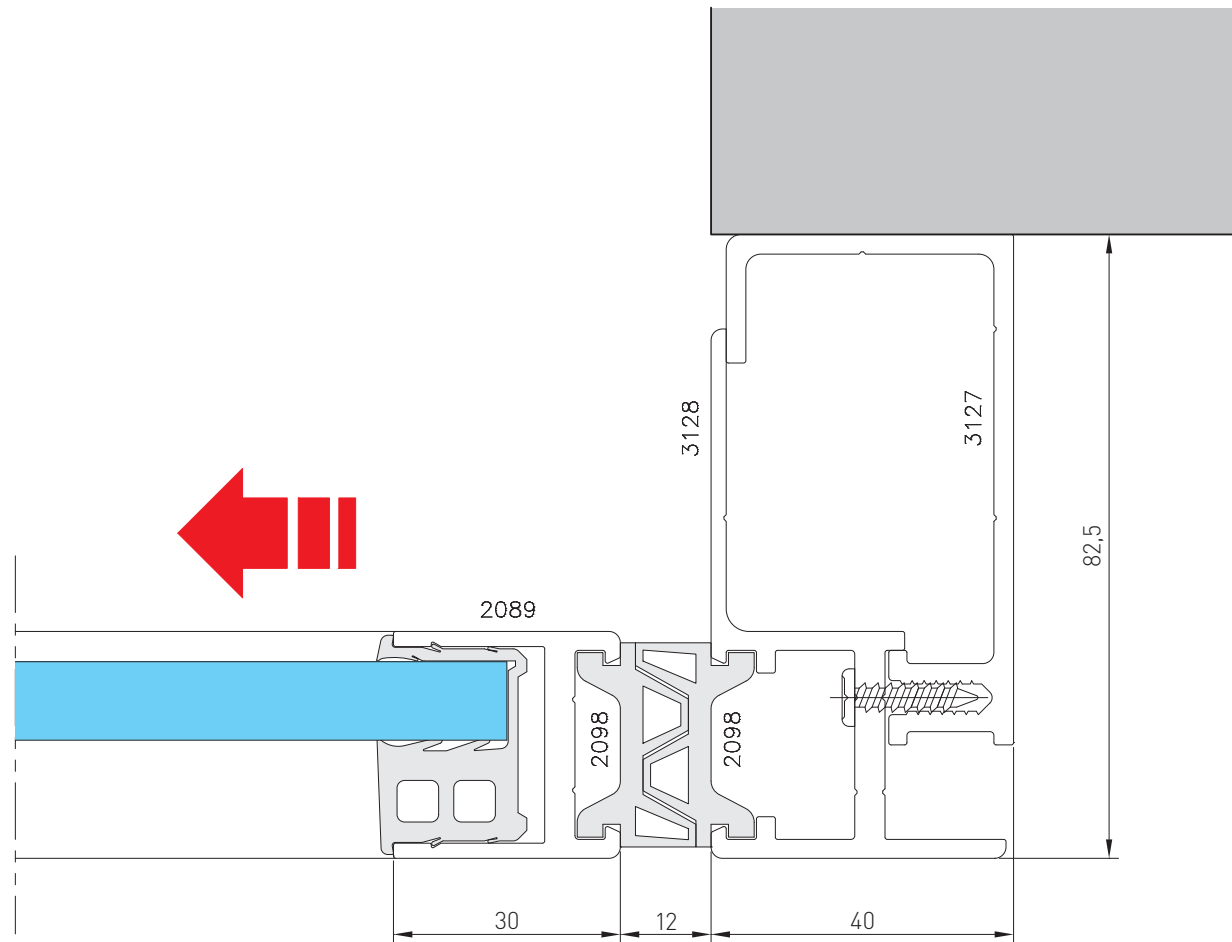

14

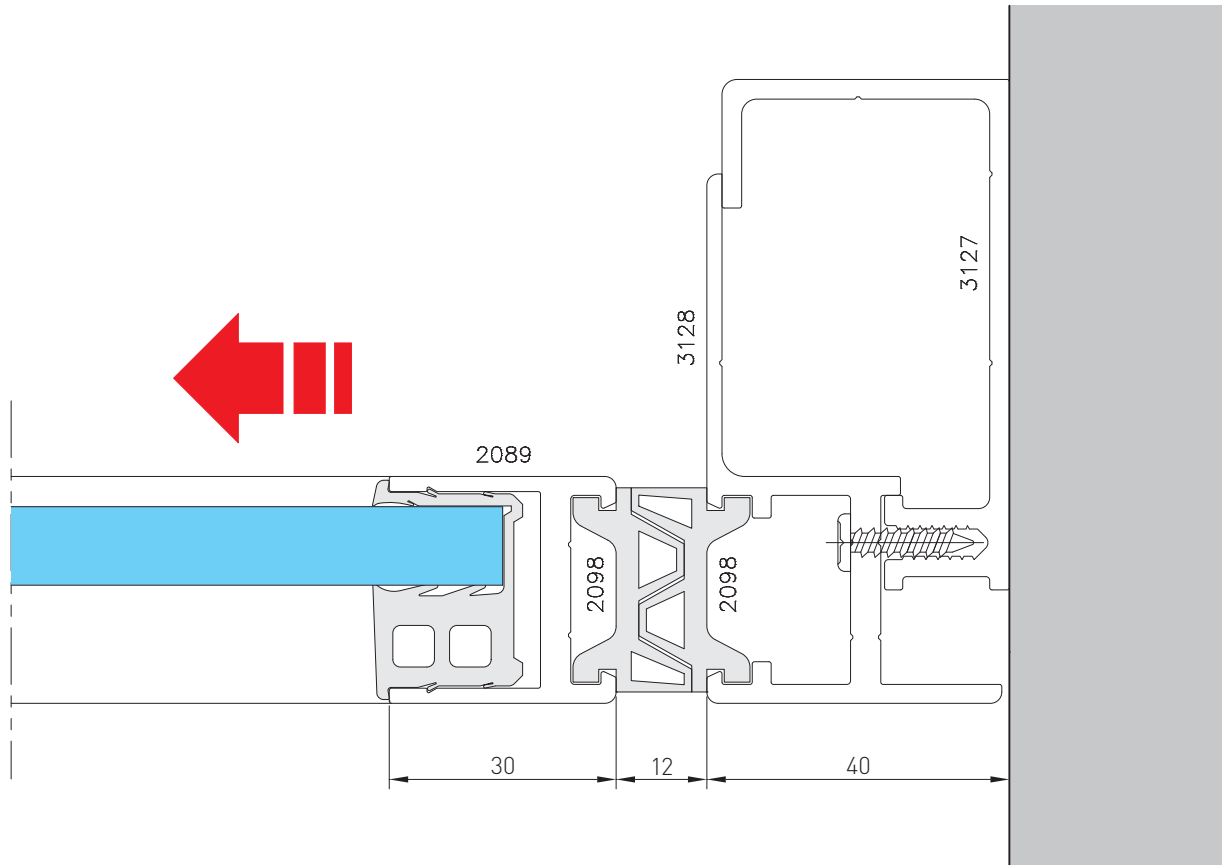

15

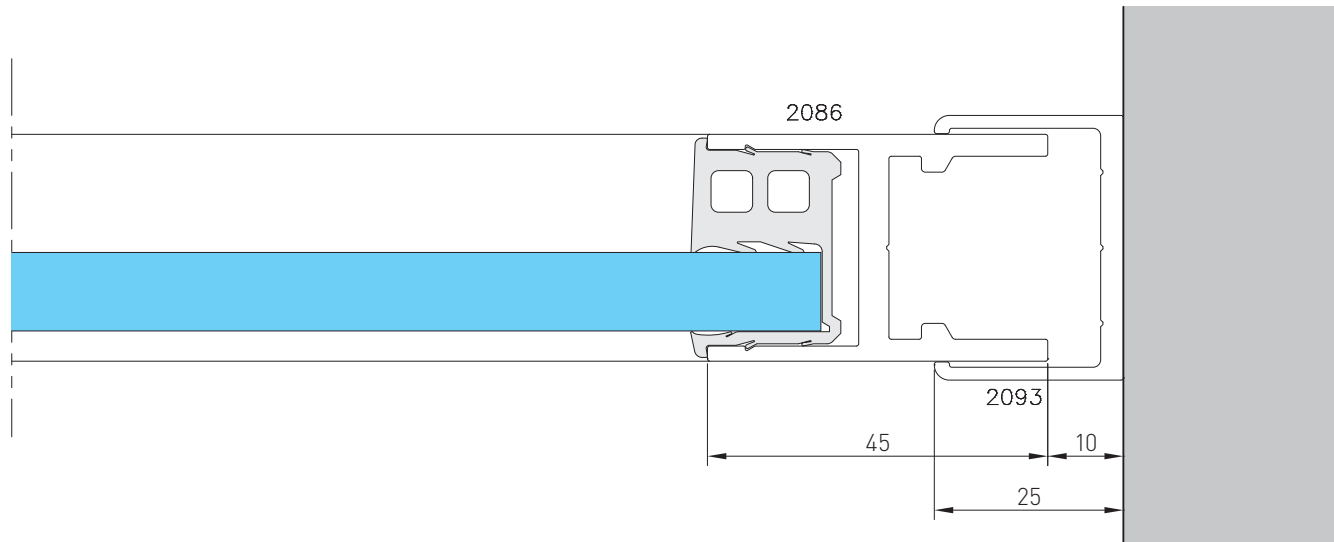

16

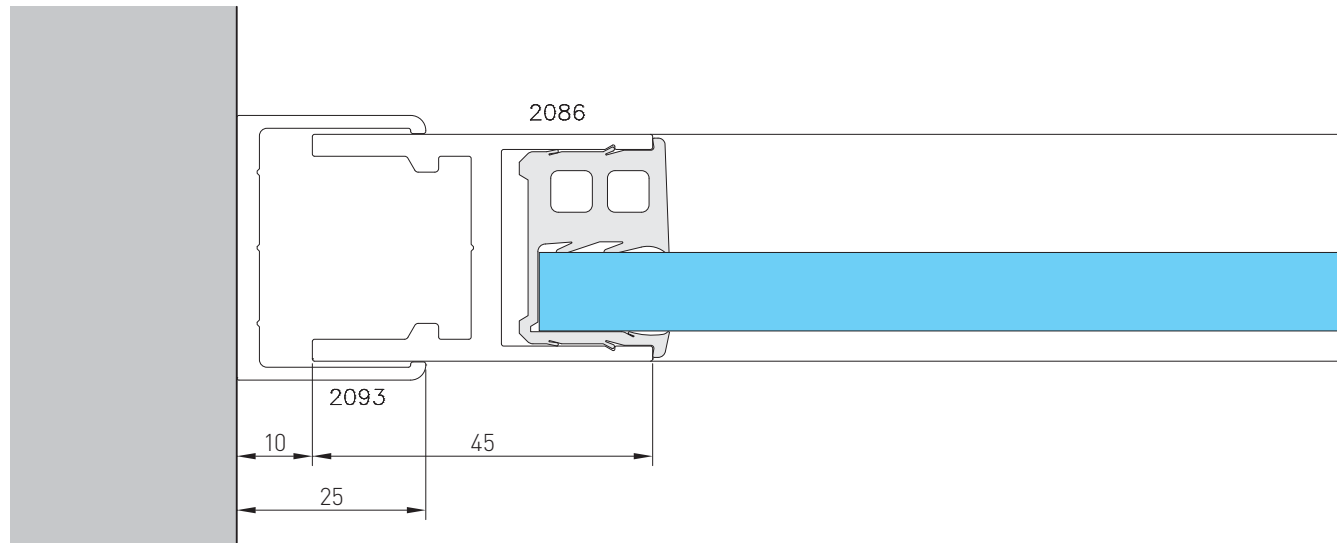

17

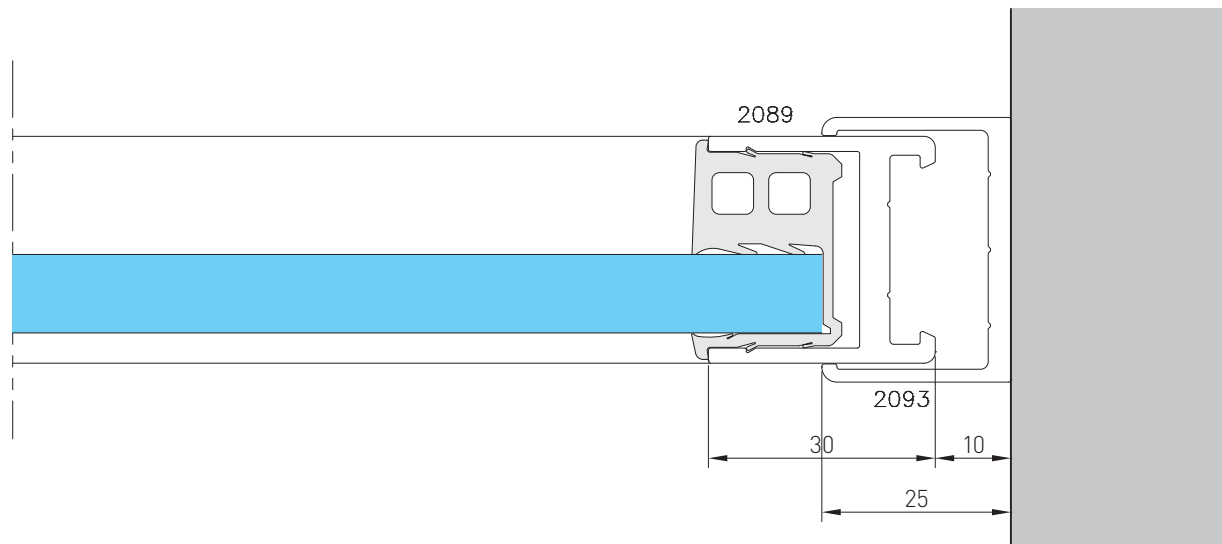

18

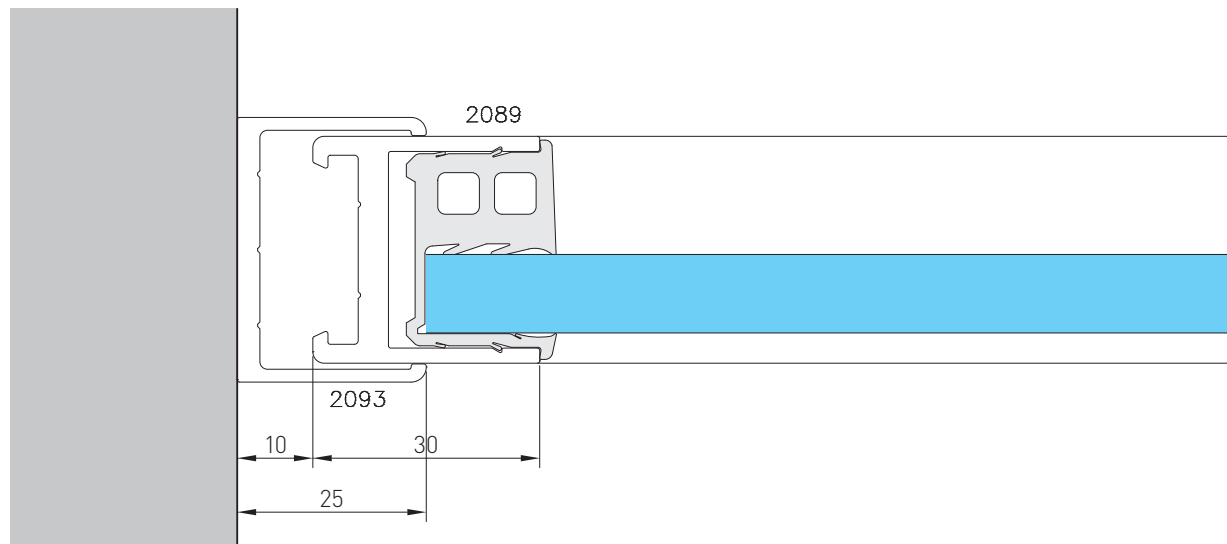

19

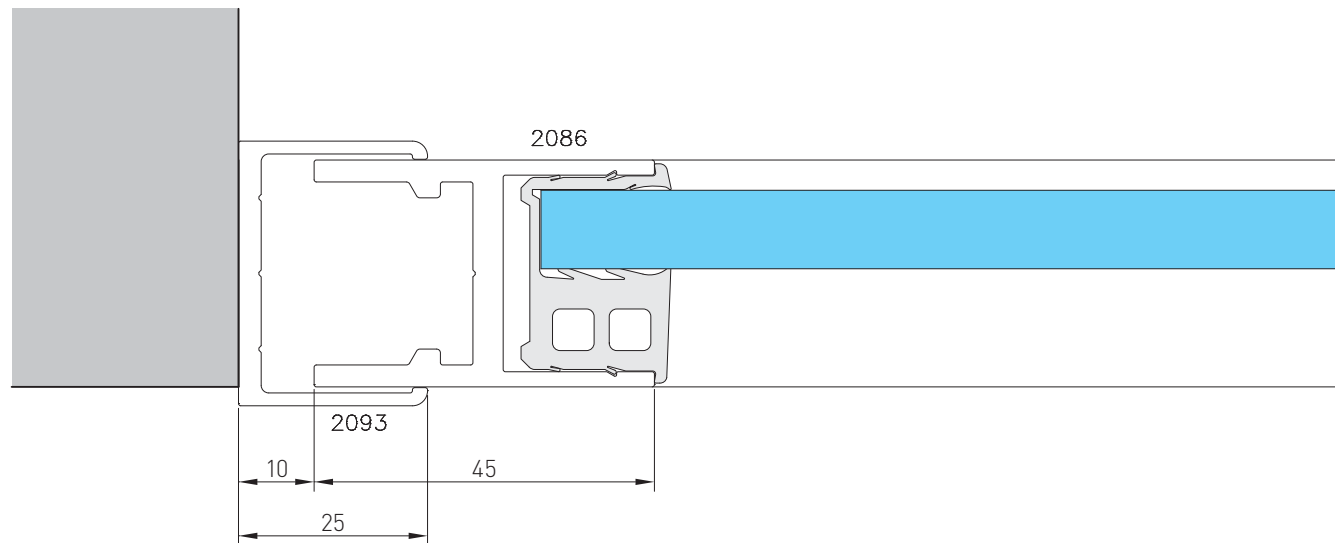

20

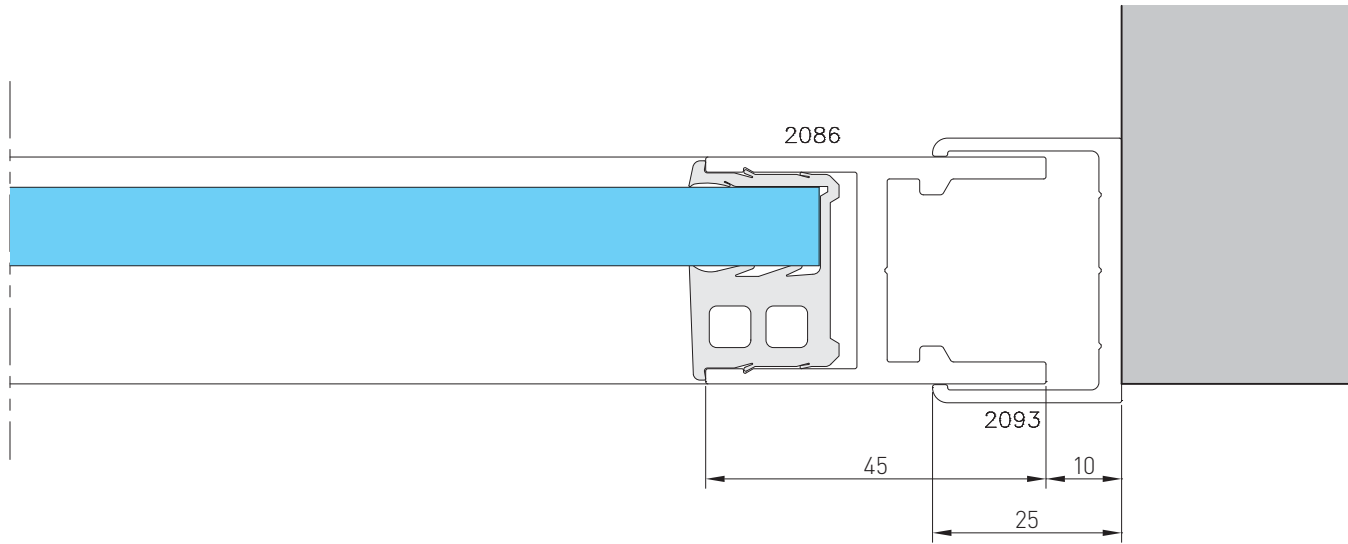

21

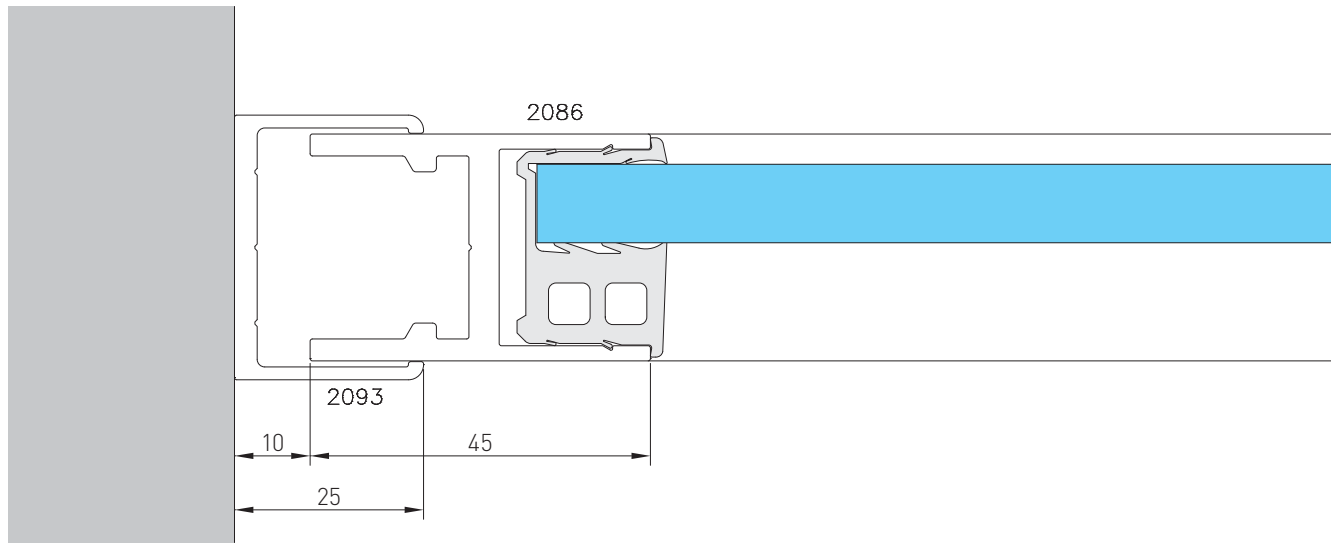

22

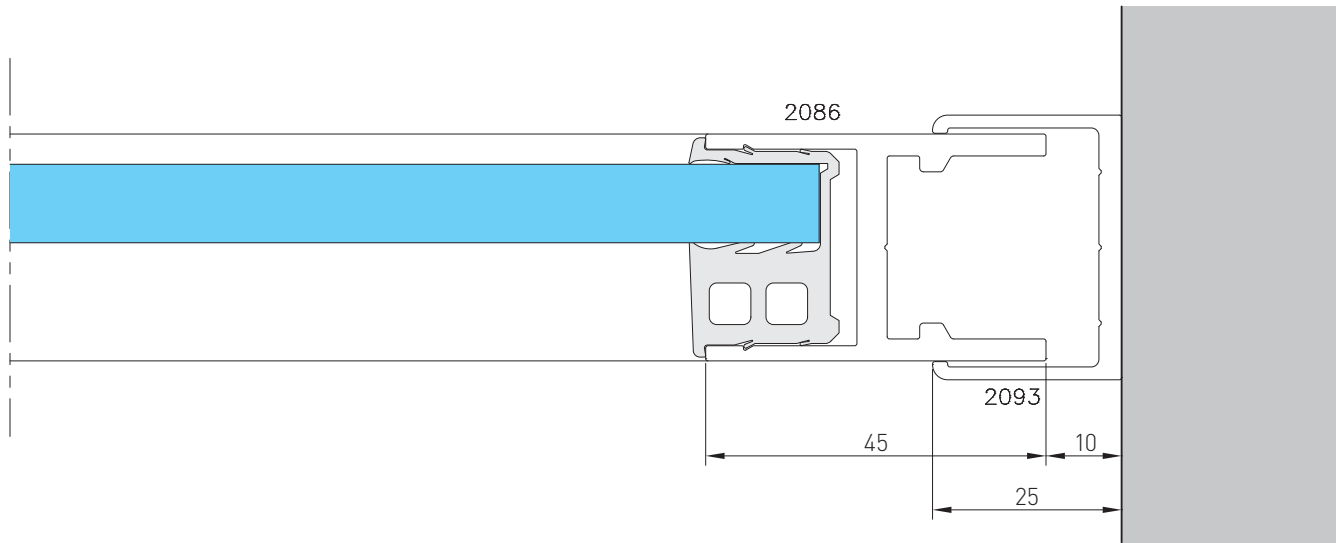

23

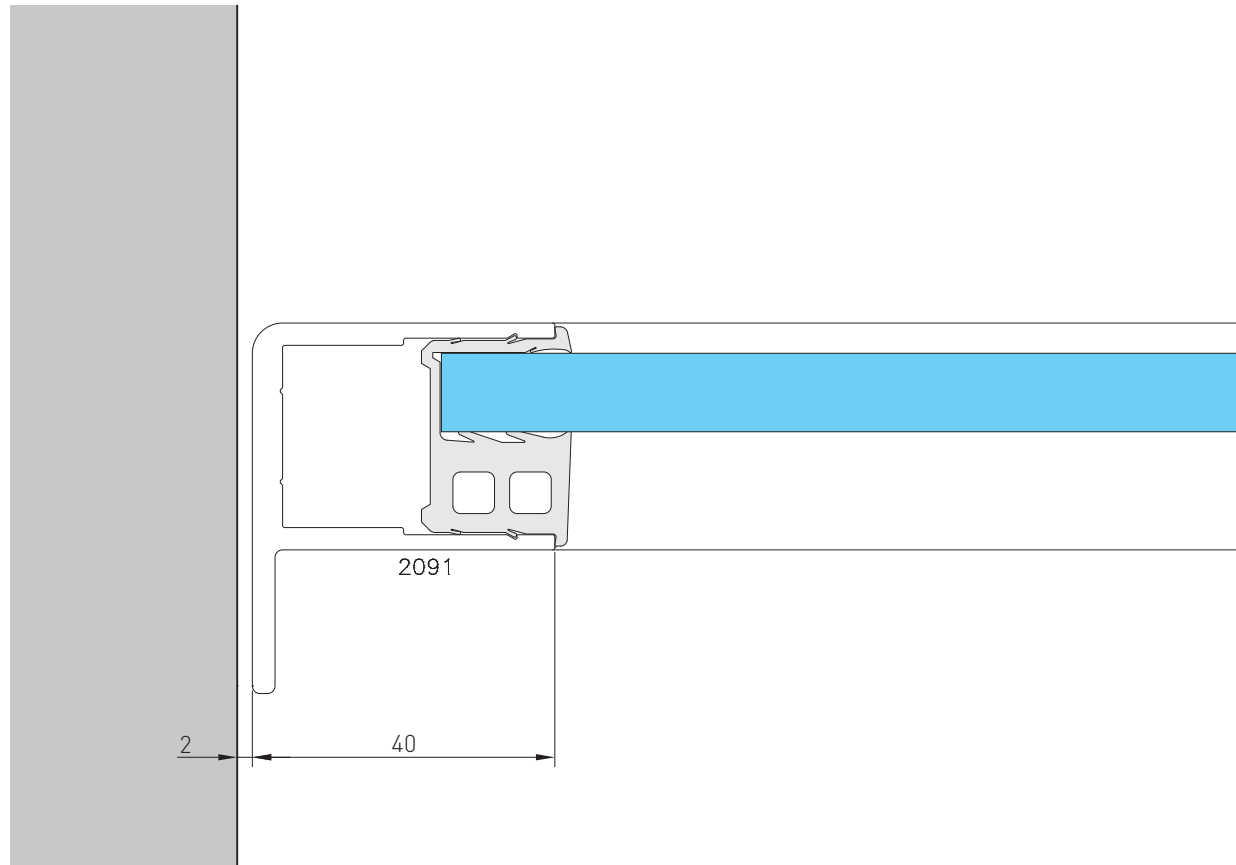

24

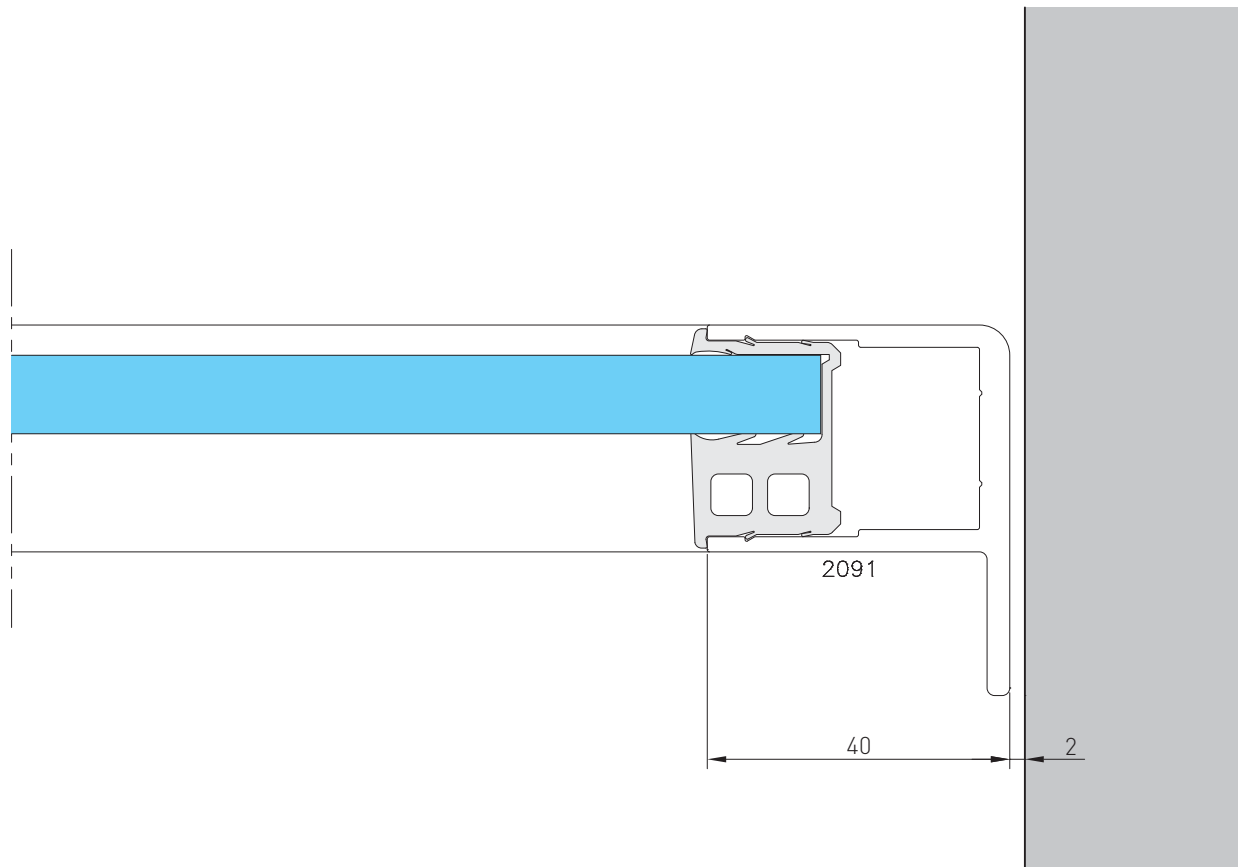

25

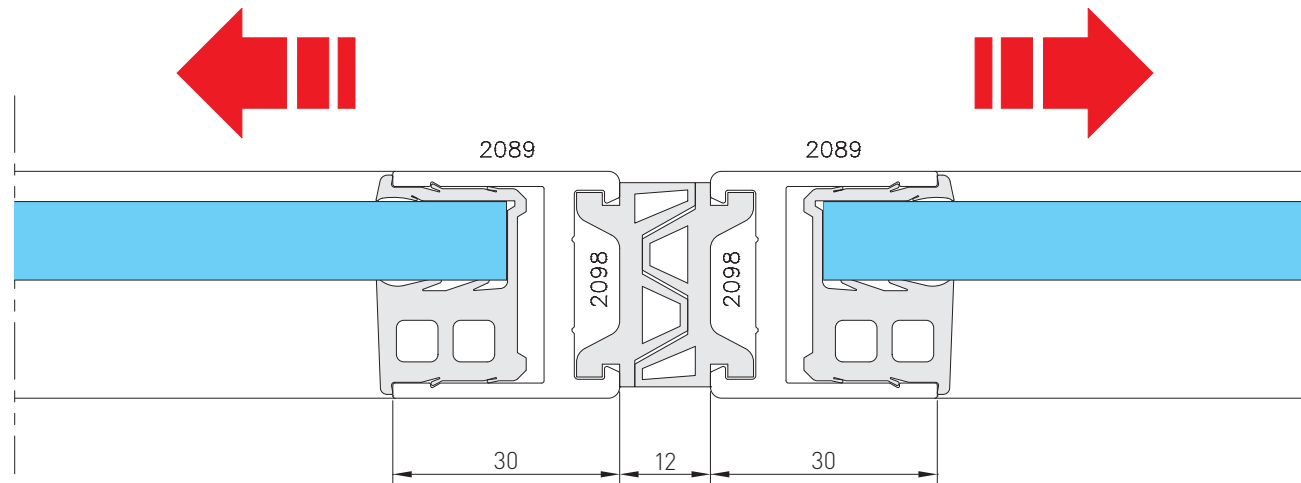

26

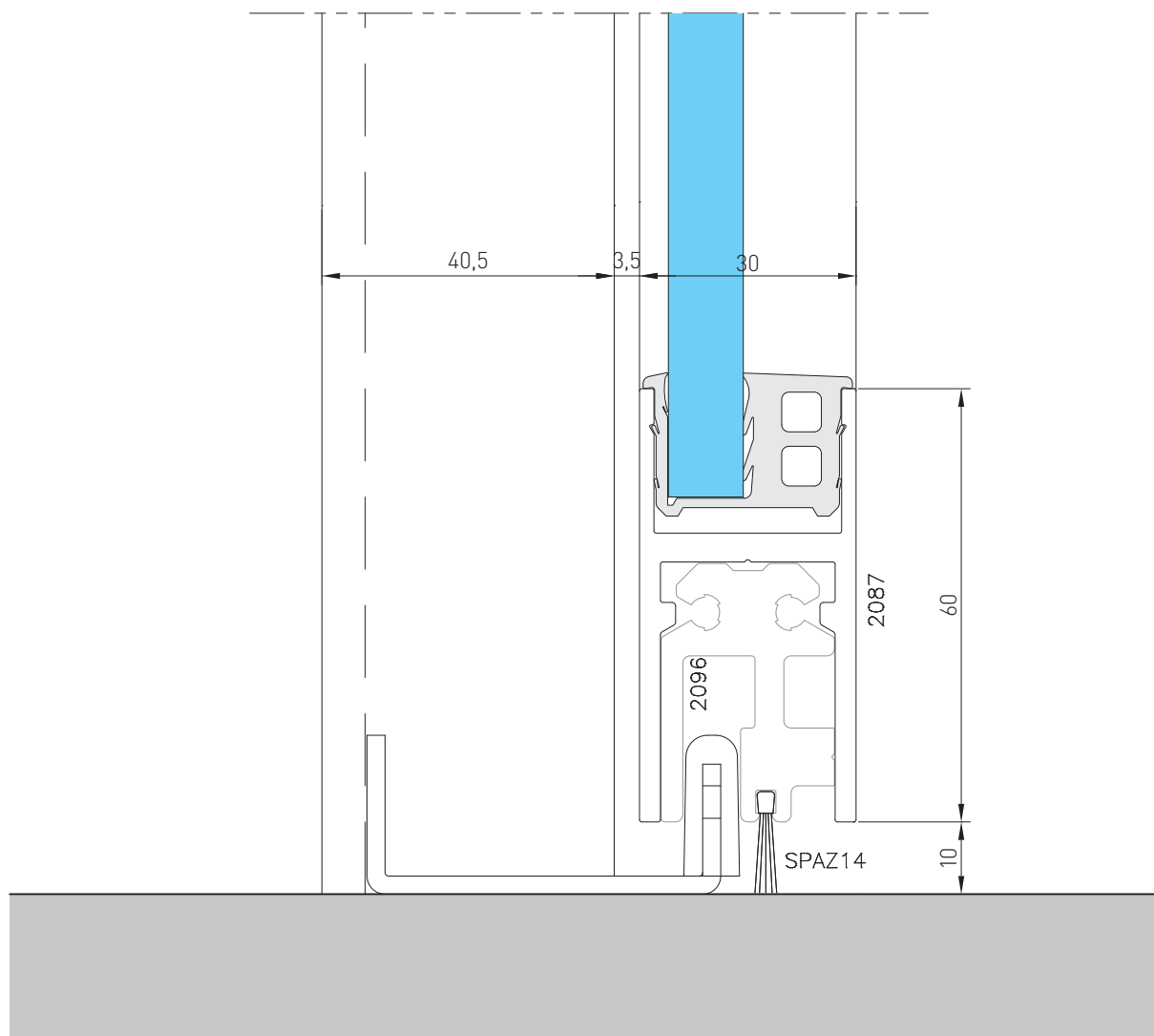

26A

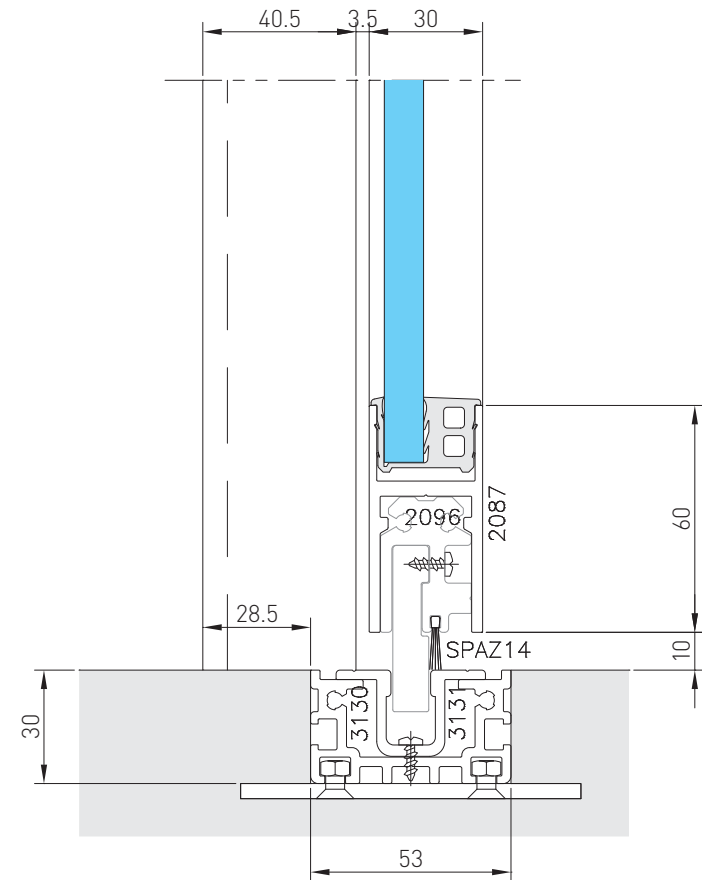
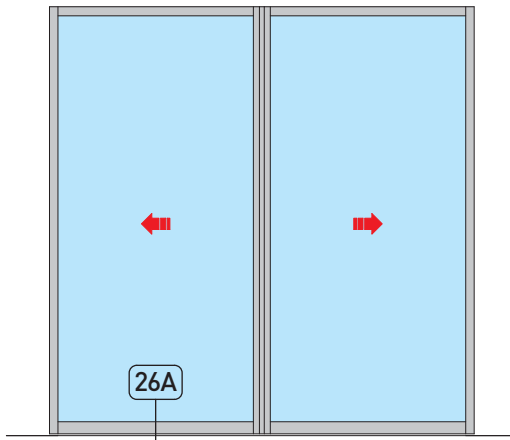
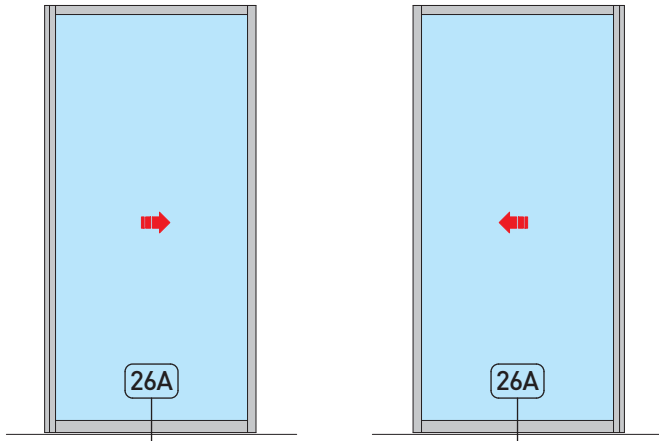

27

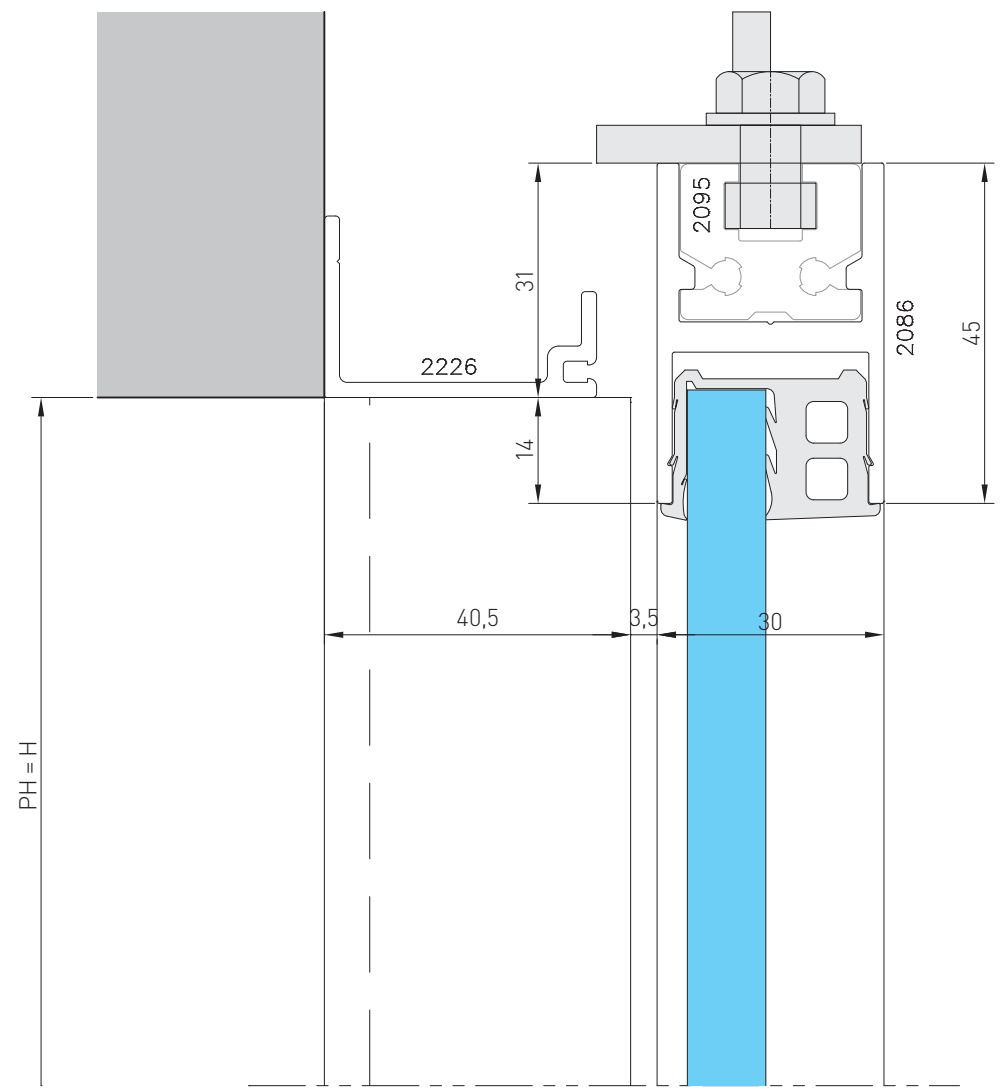

28

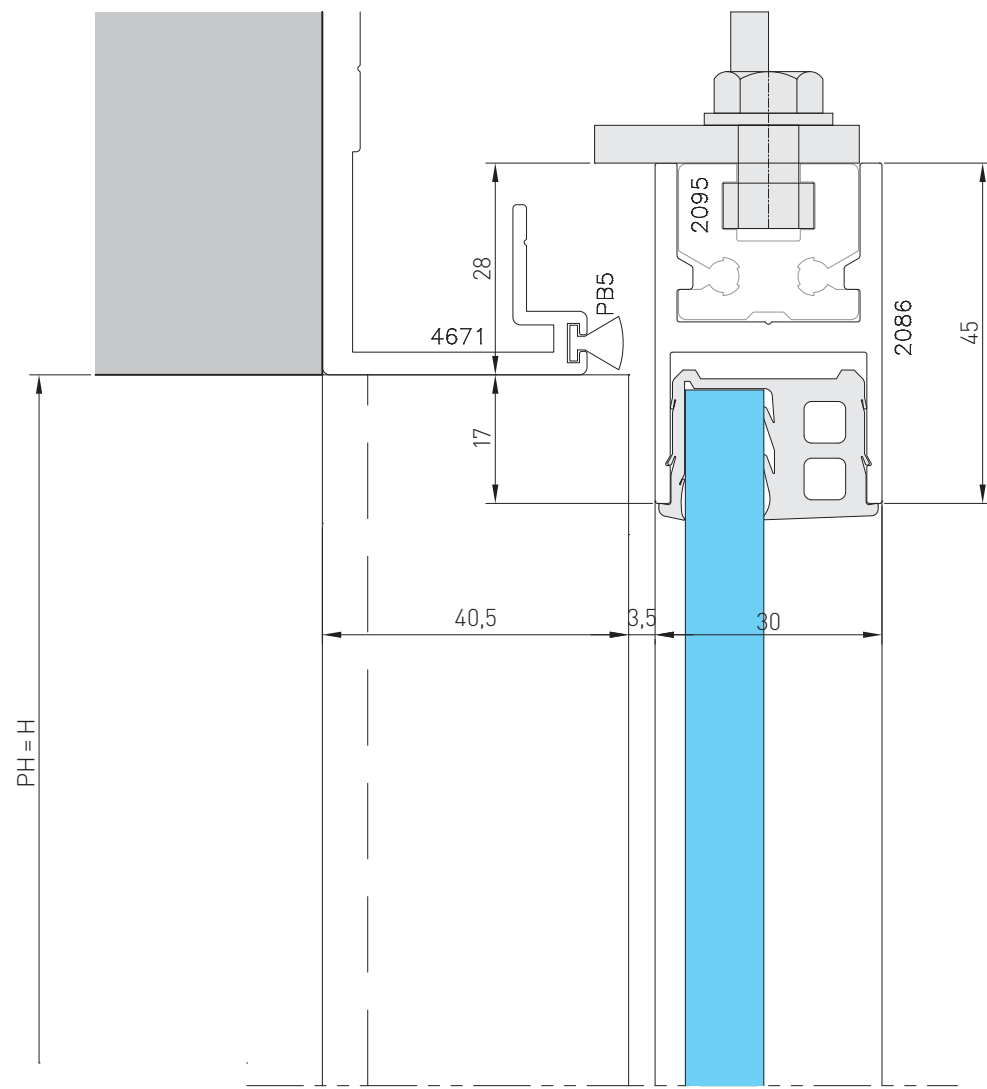

30

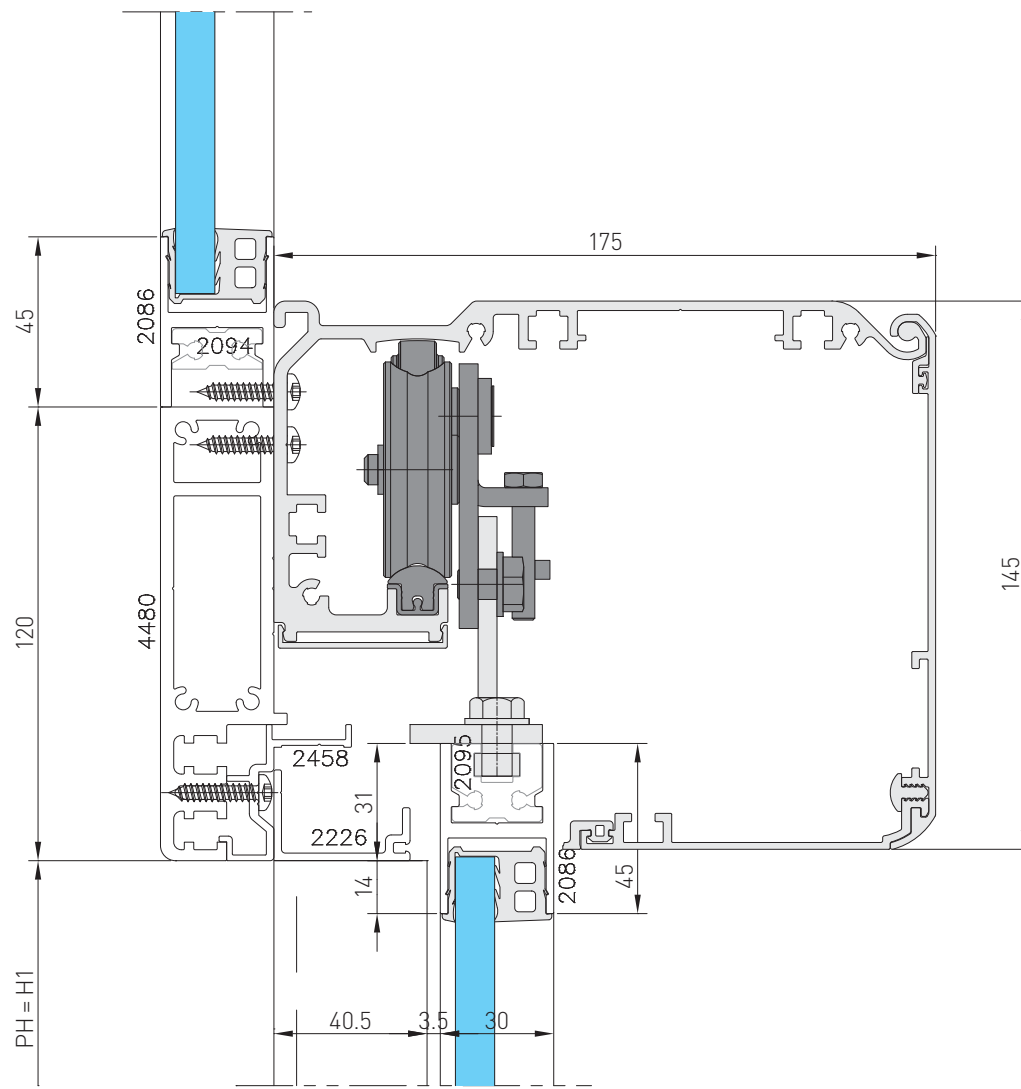

31

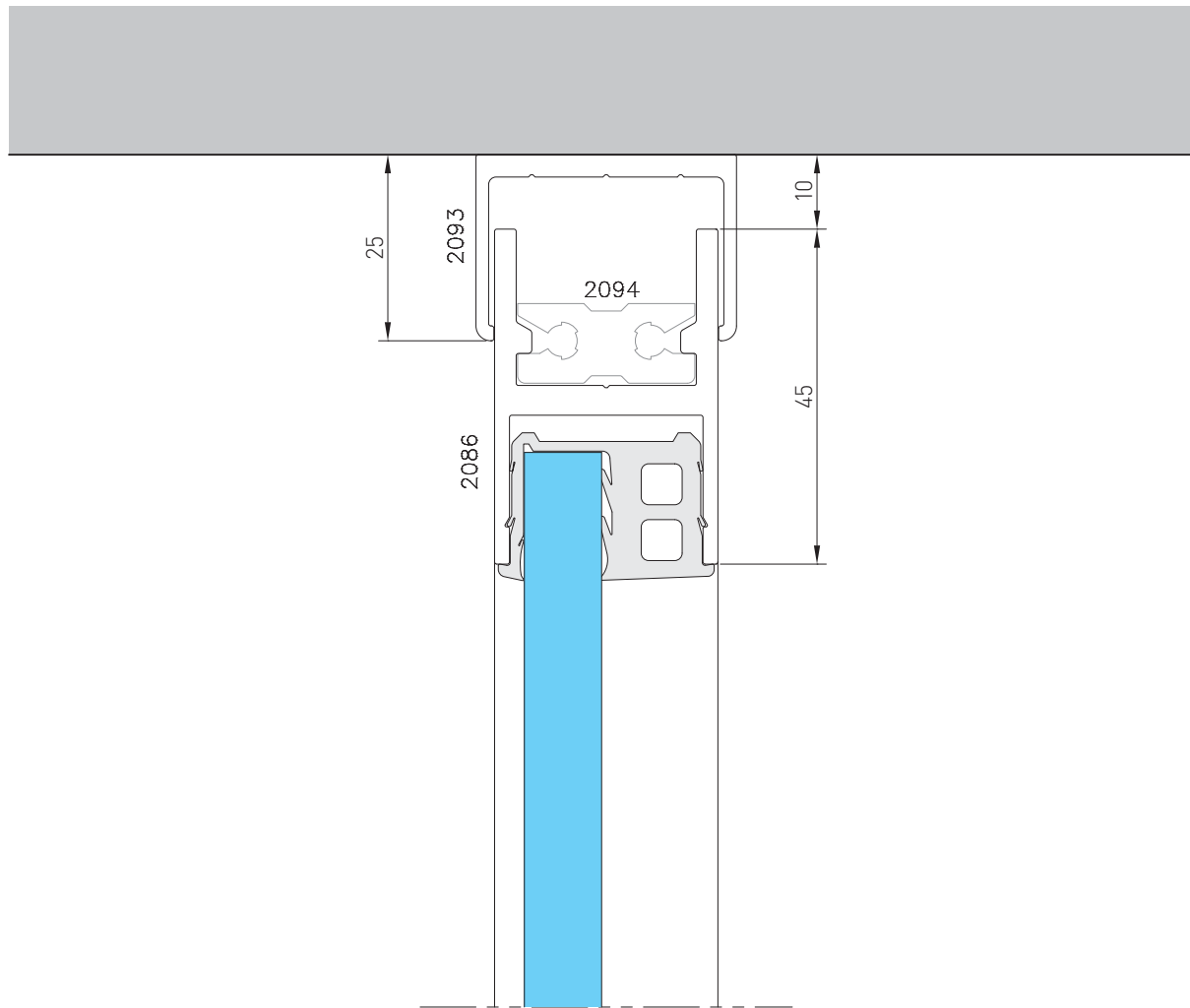

33

32

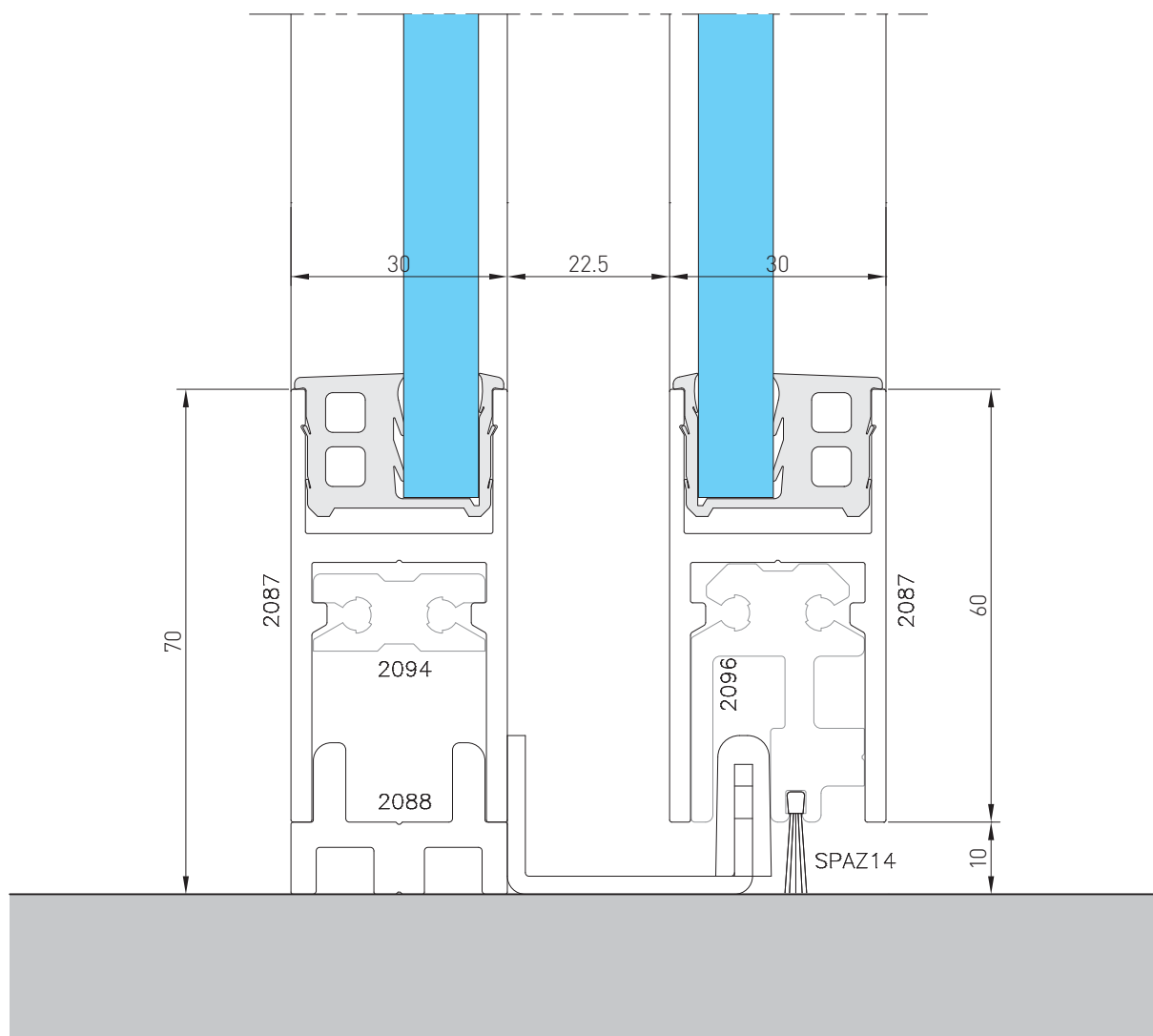

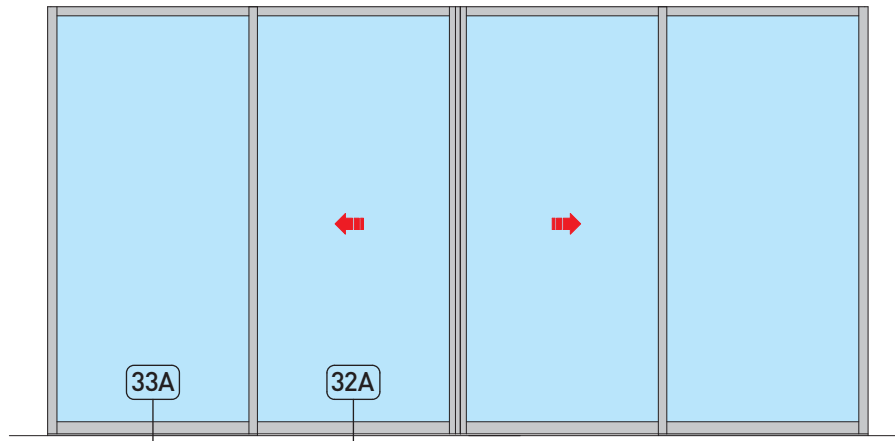
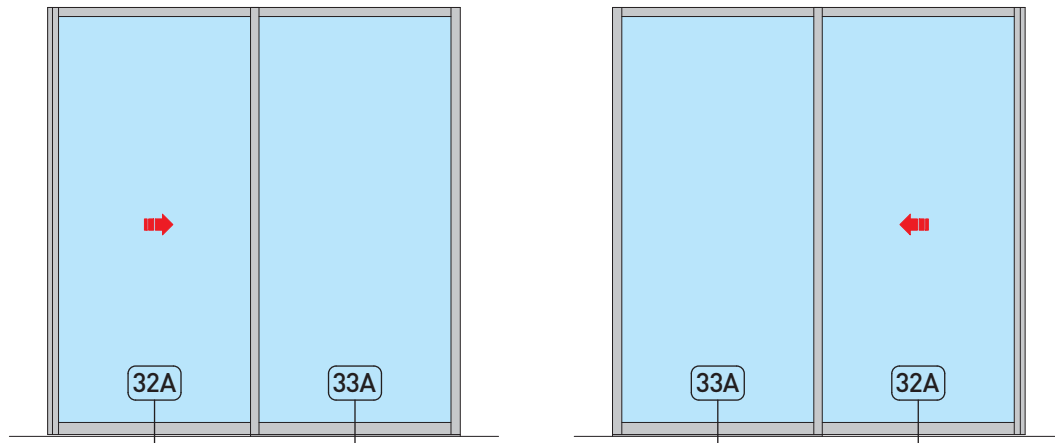

33A **32A**

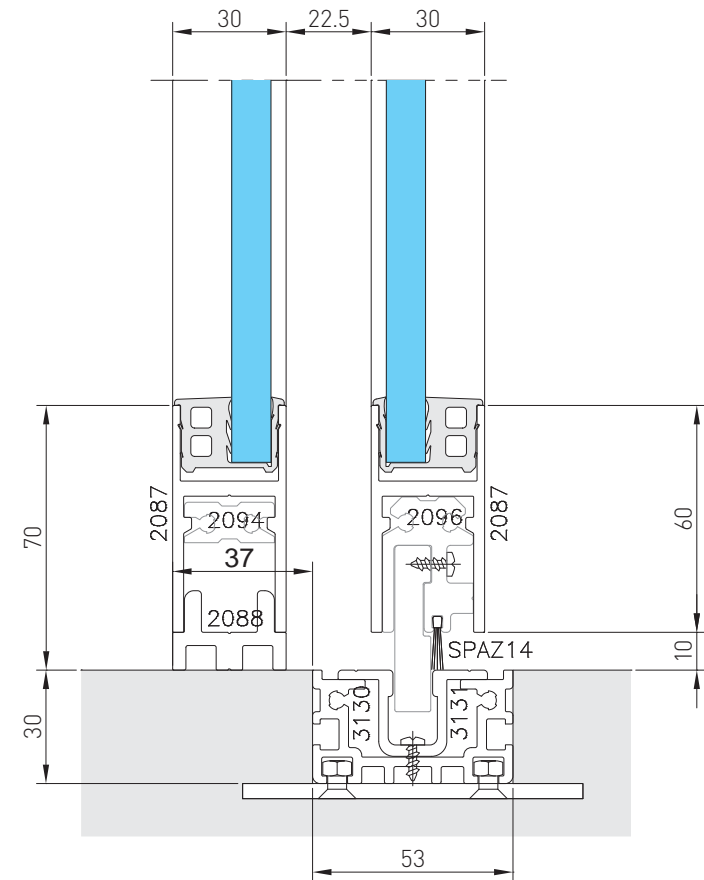

37

36

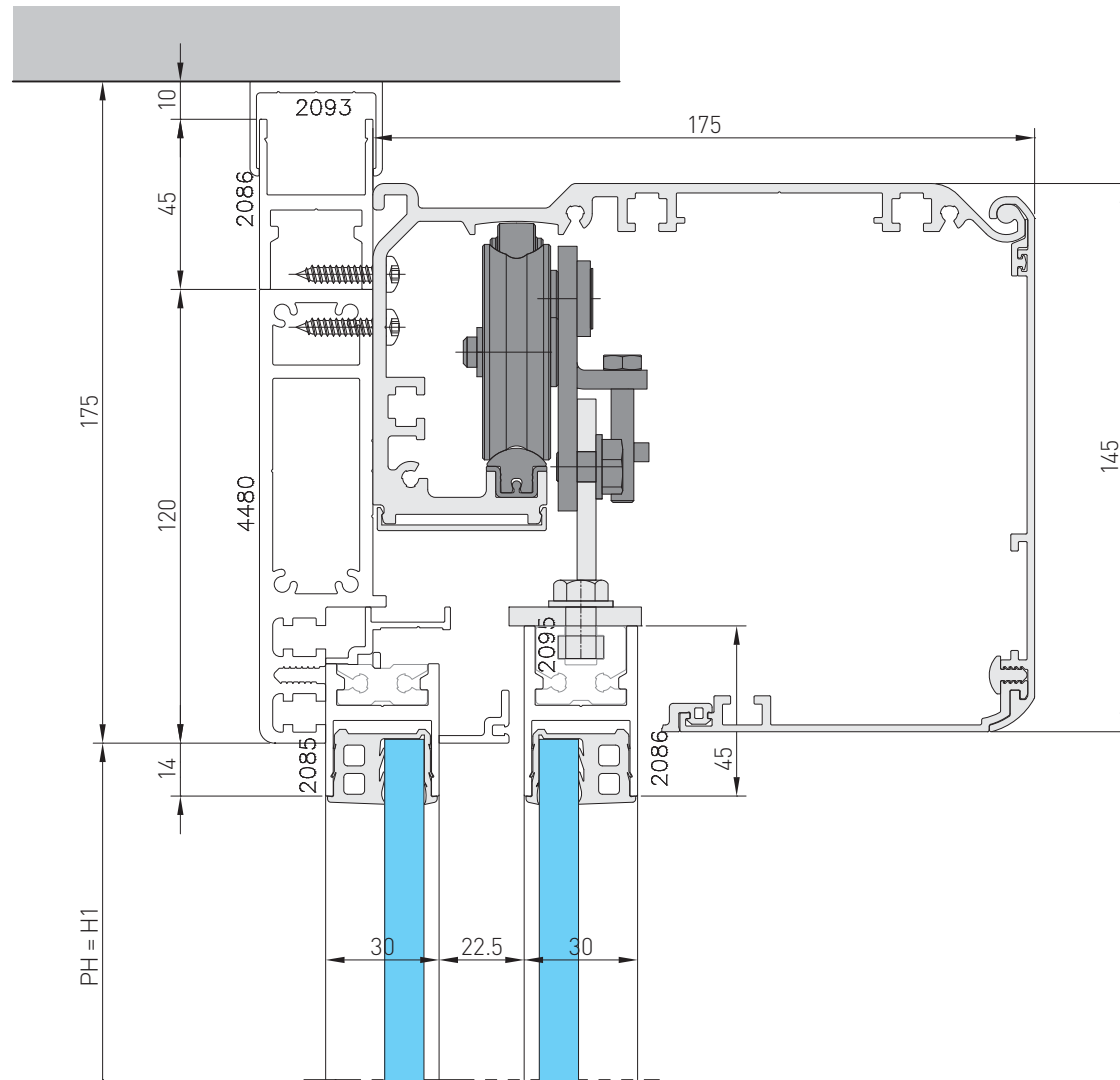

39

38

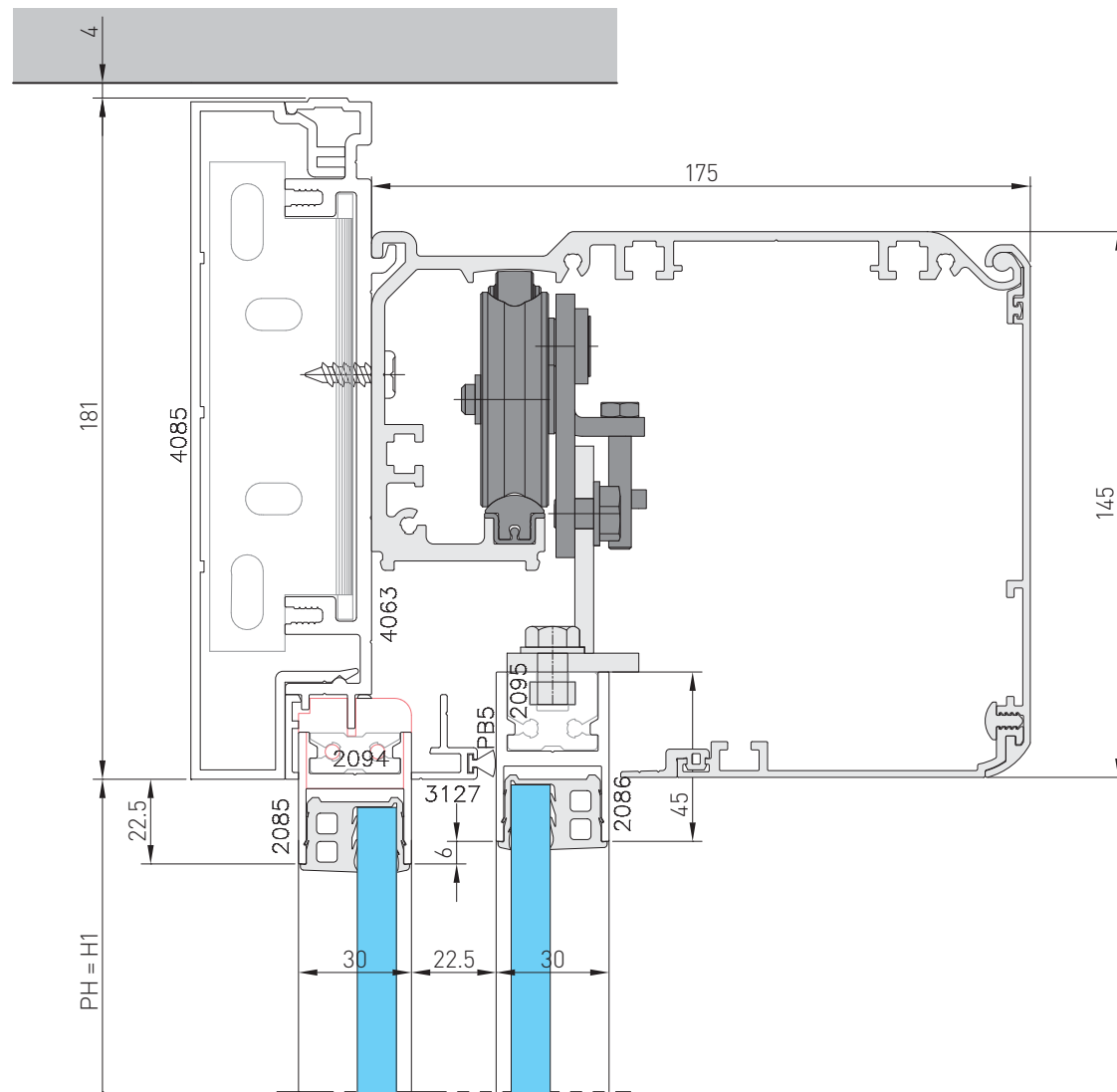

41

40

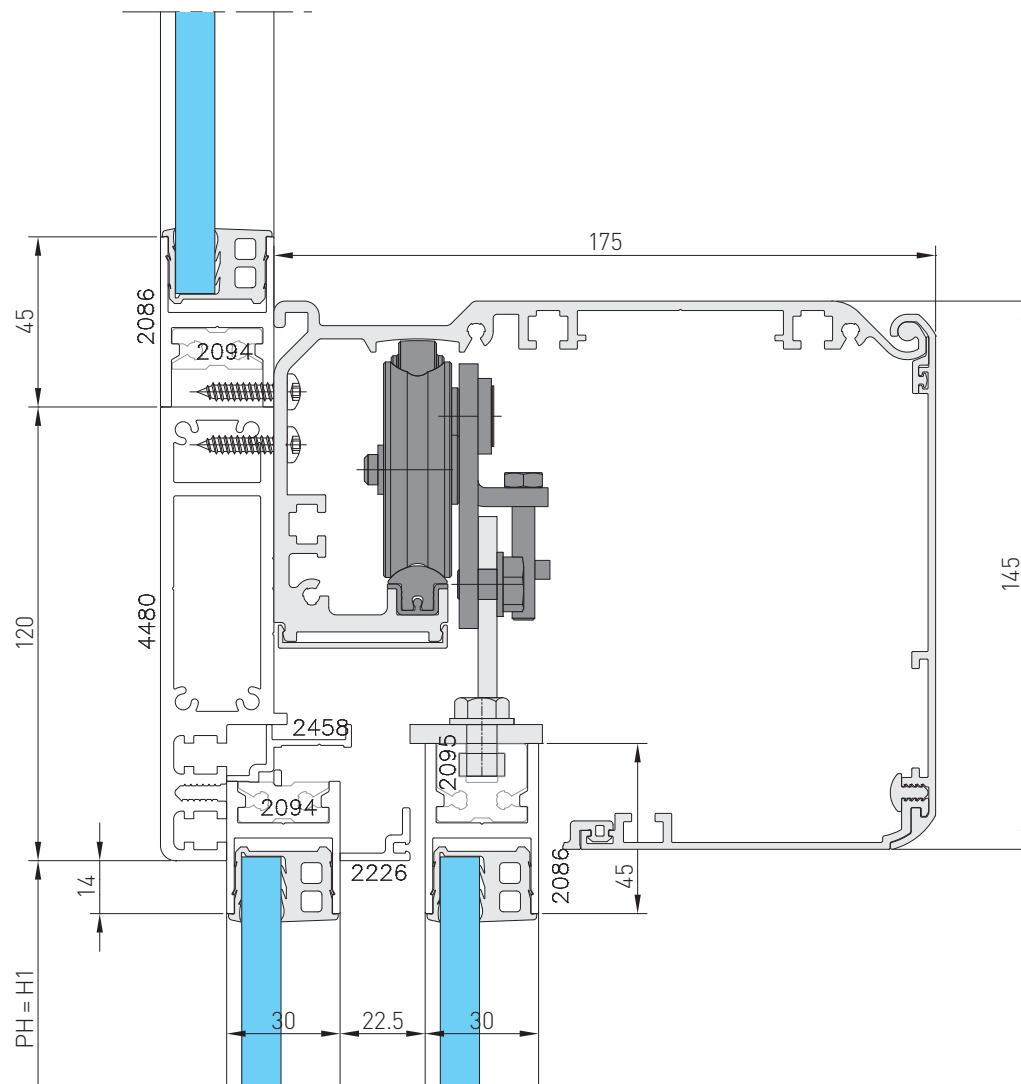

44

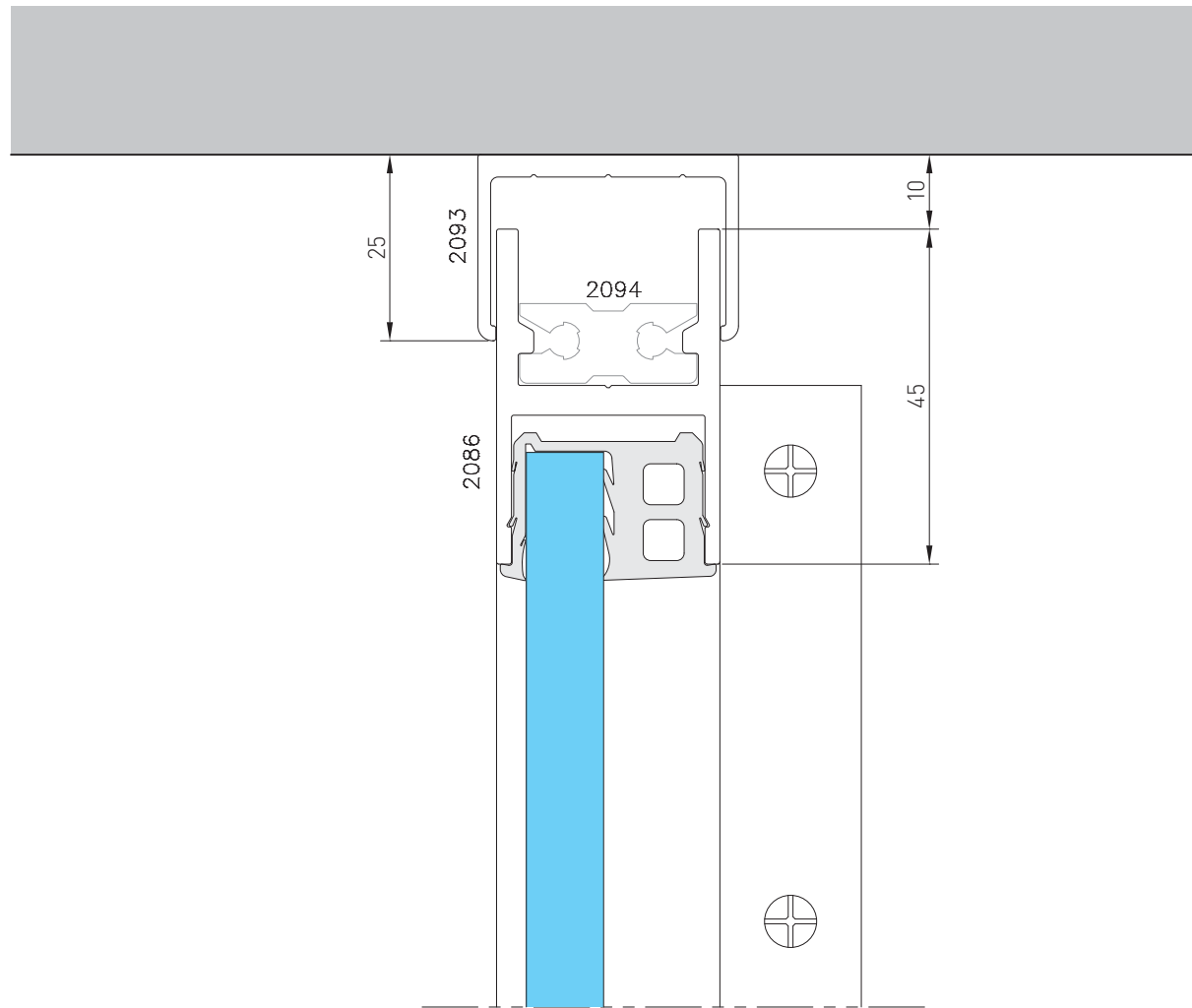

47. Processes

- M** Moving door wing
- Anta mobile
- Fahrflügel
- Vantail mobile
- Hoja móvil
- Portinhola móvel

T91

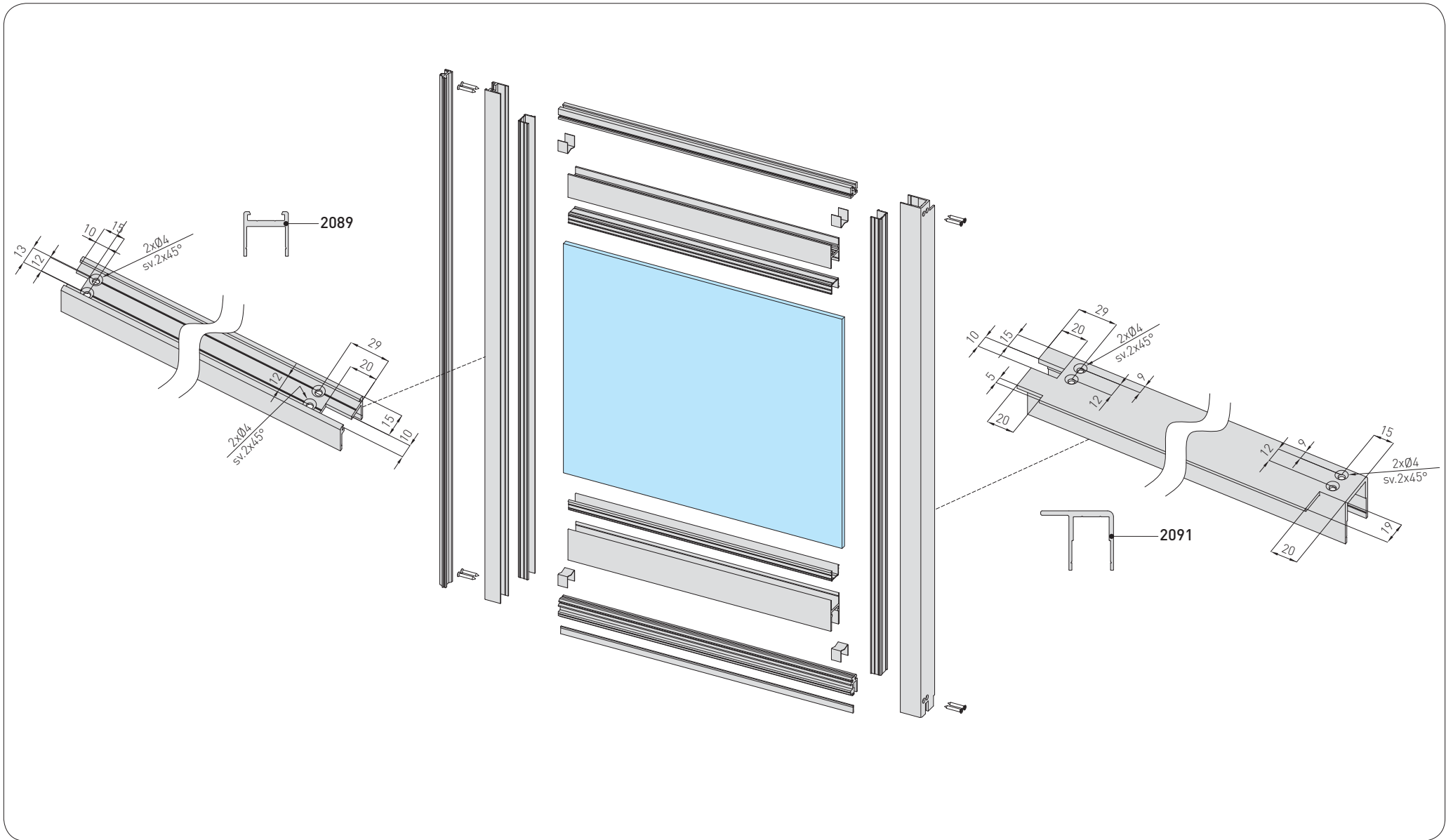

47. Processes

- F** Fixed door wing
- Anta fissa
- Seitenteil
- Vantail fixe
- Hoja fija
- Portinhola fixa

T92

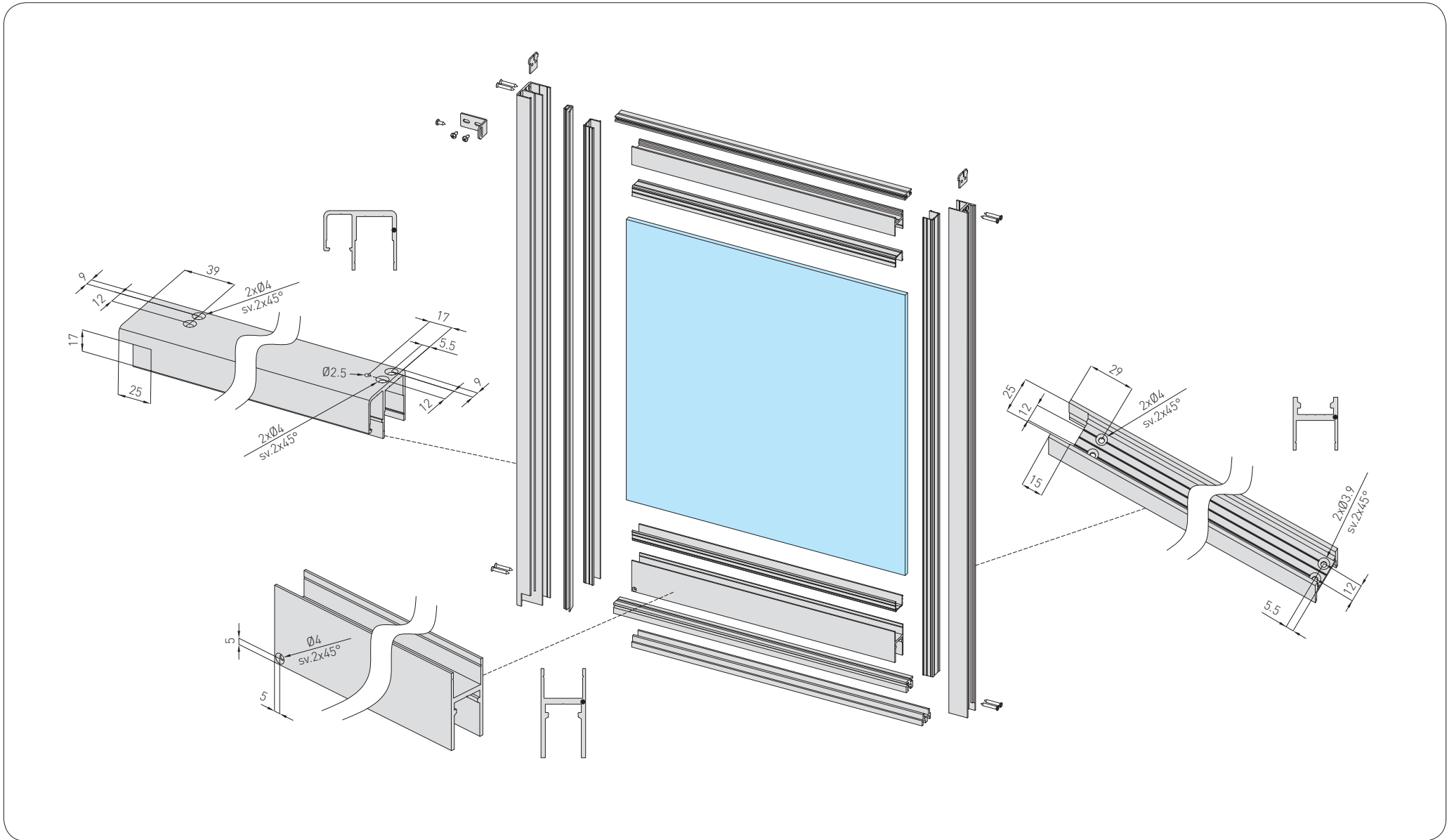

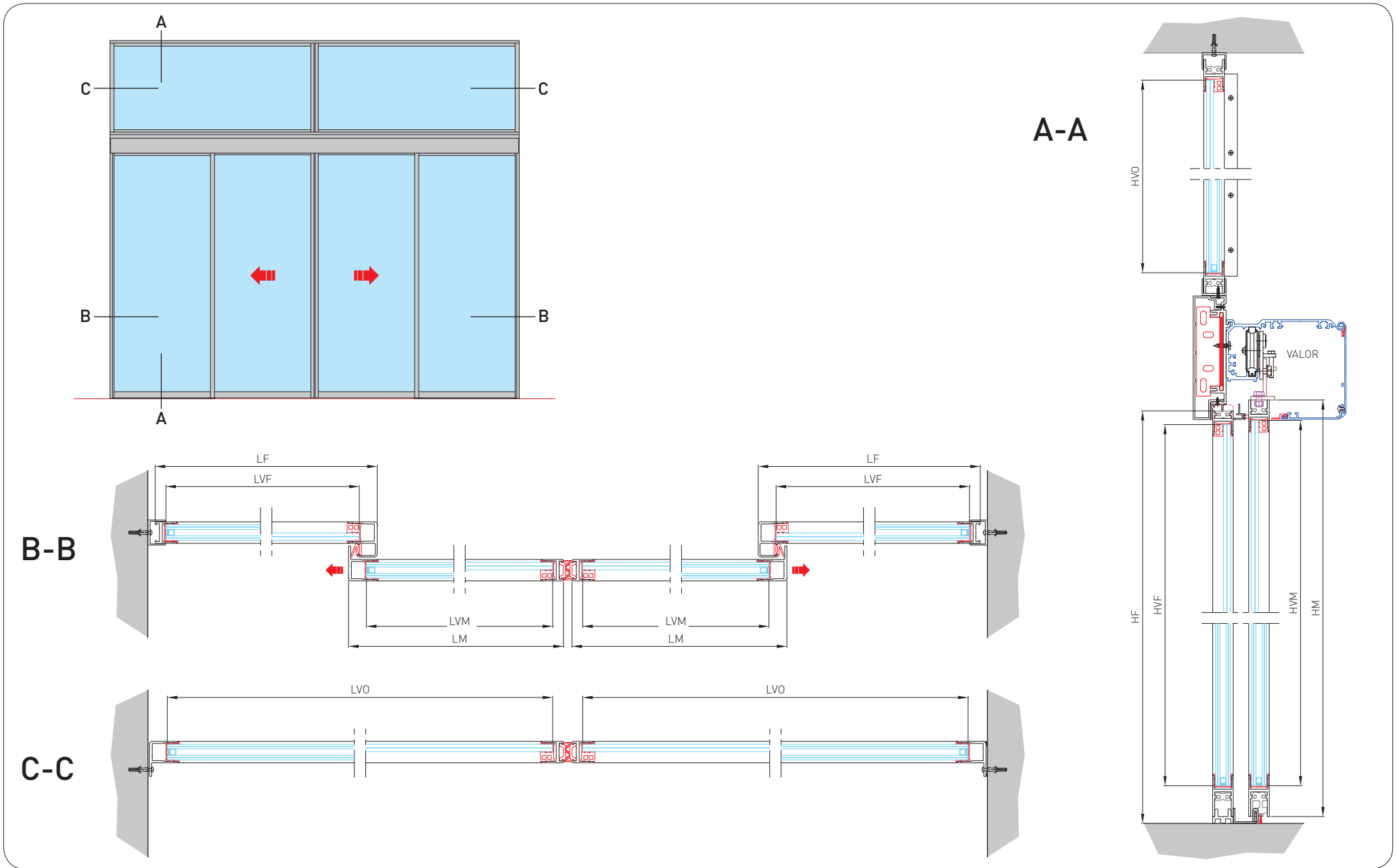

49. Instructions for assembling and installing (list of types)

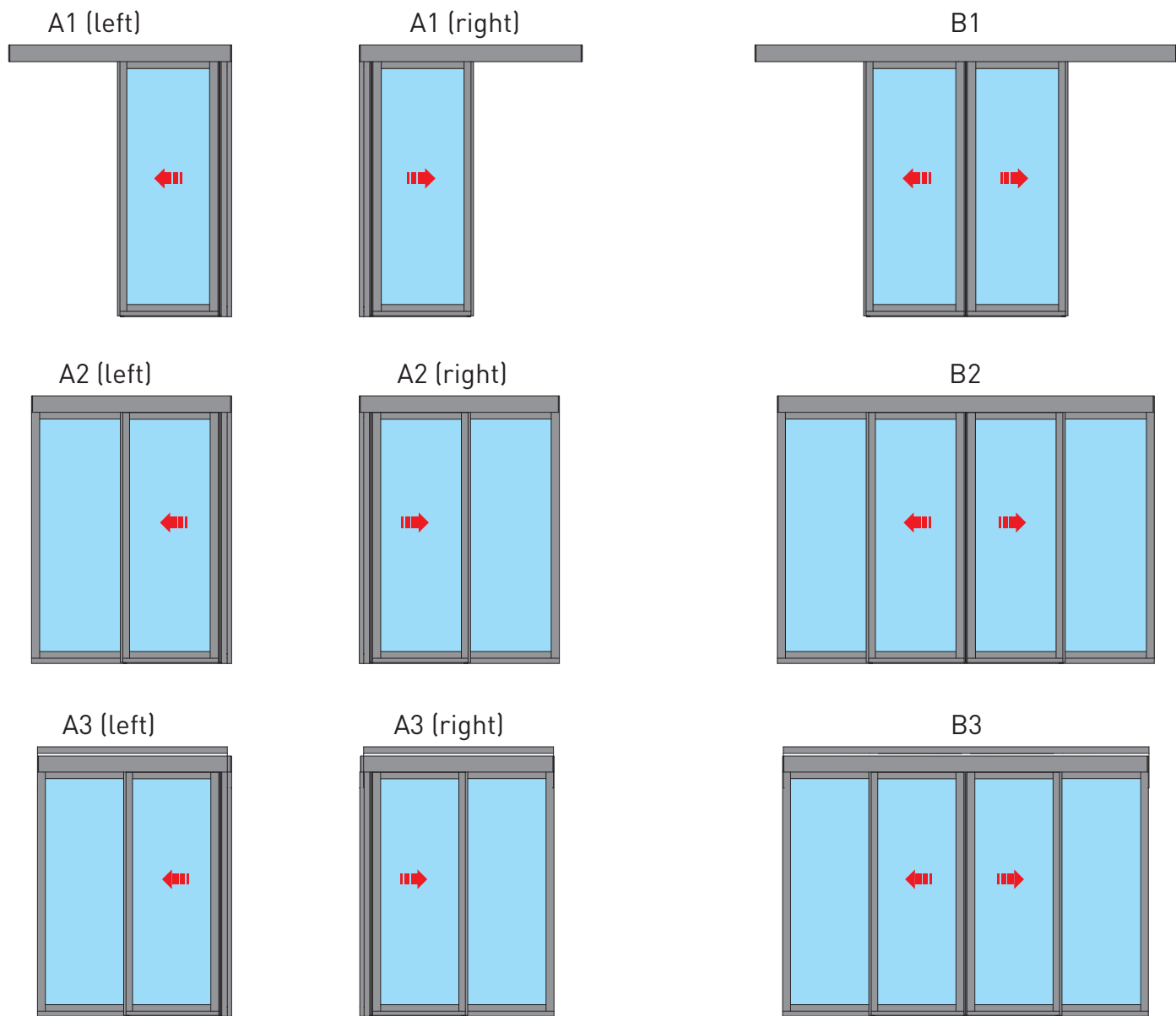

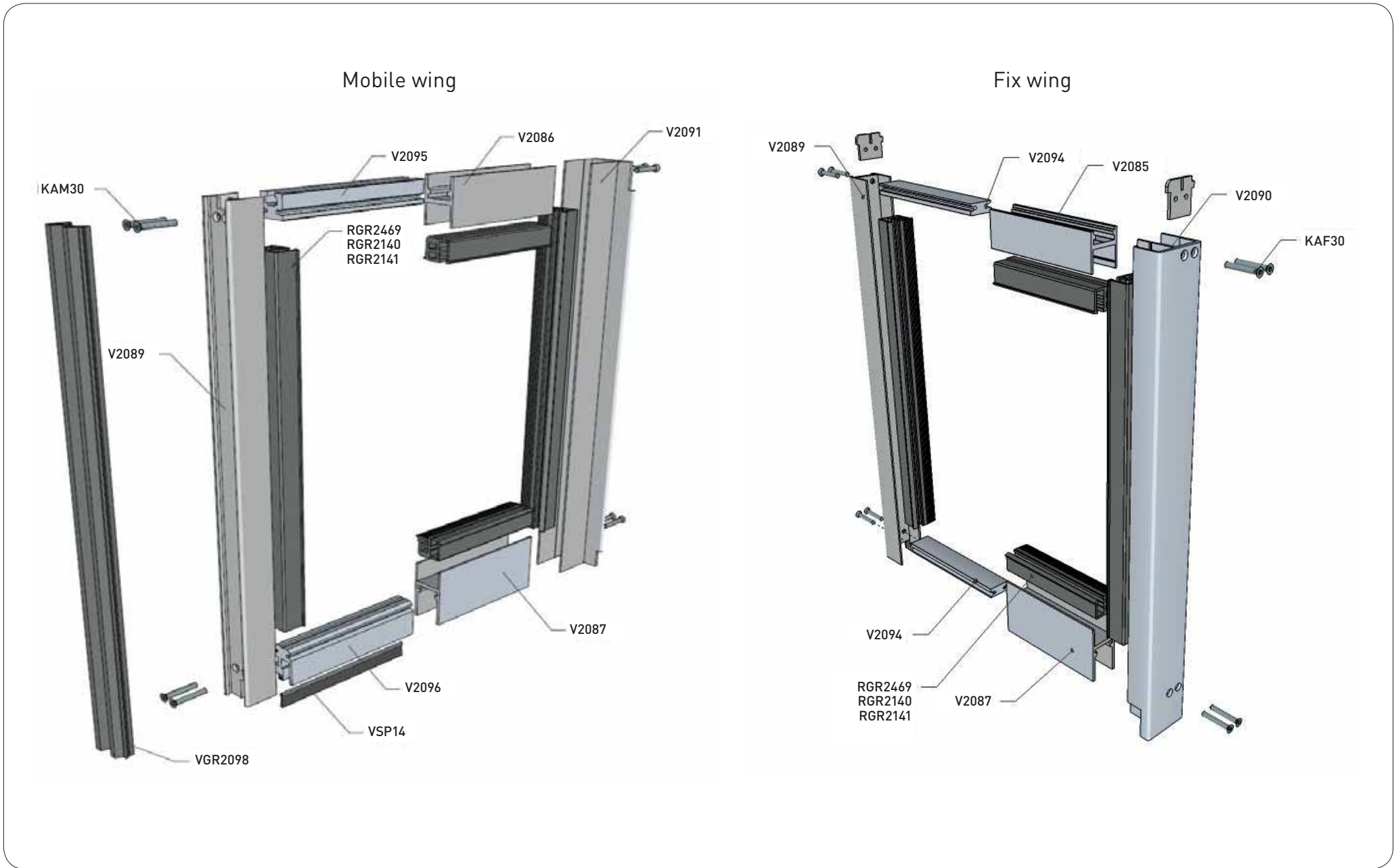

1

Frame post fixing

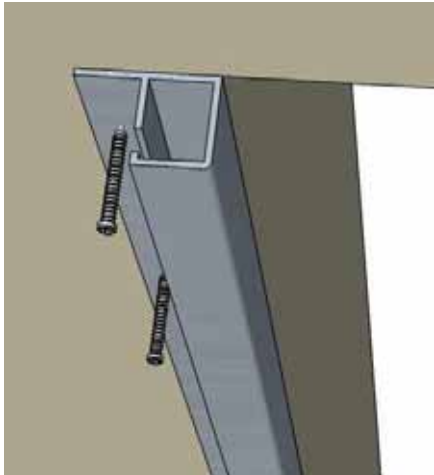

2

Floor guide fixing

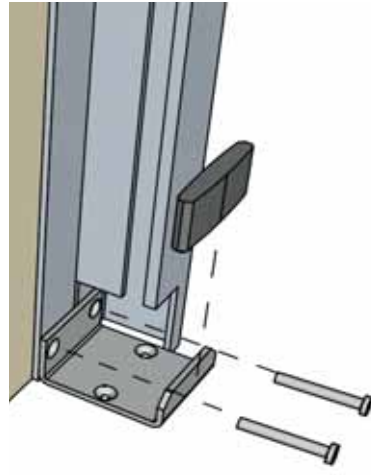

3

Wing positioning

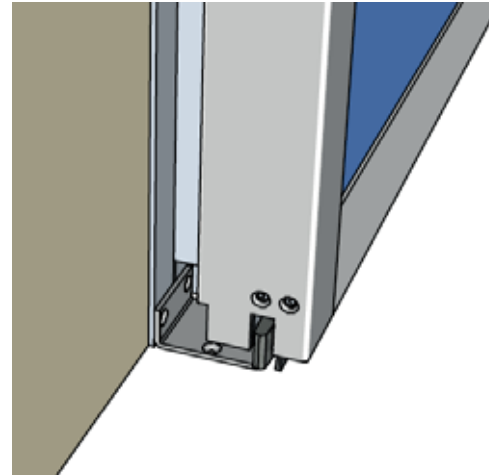

4

Post closing fixing

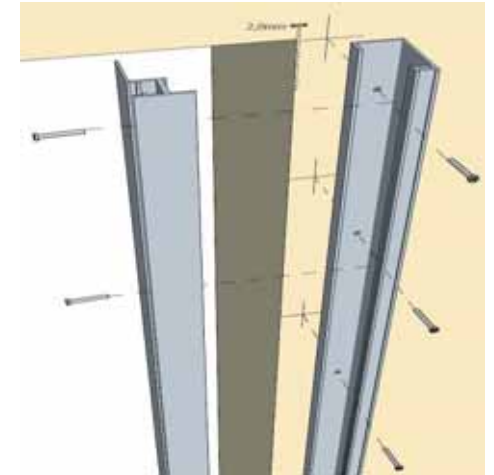

5

Simplified beam fixing

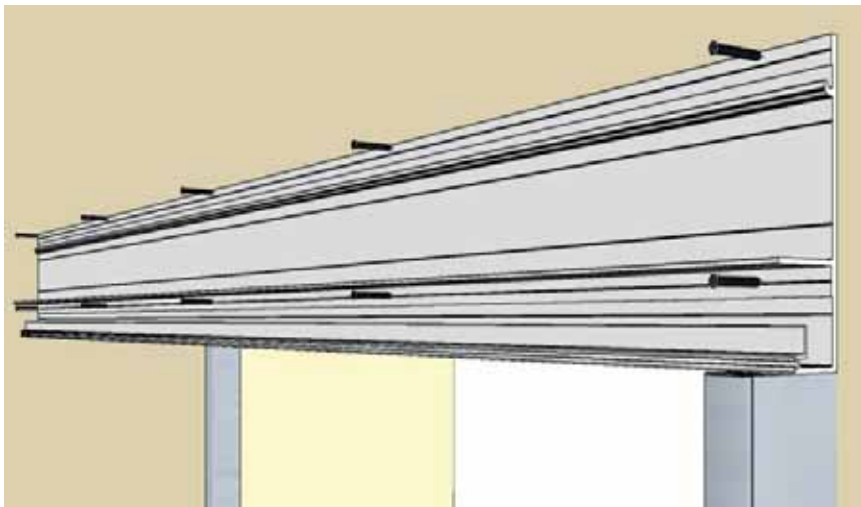

6

Automation climbing

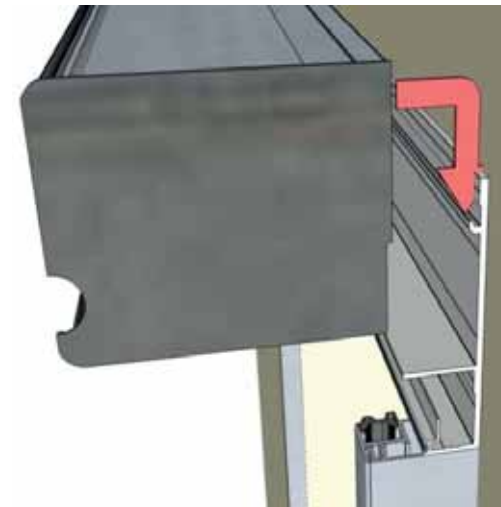

7

Operator fixing

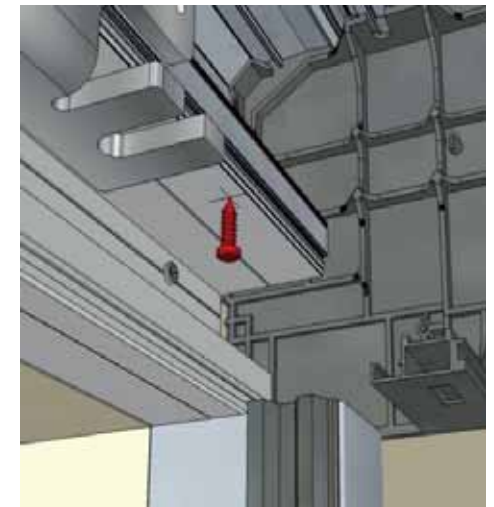

7

Fixing frame installation

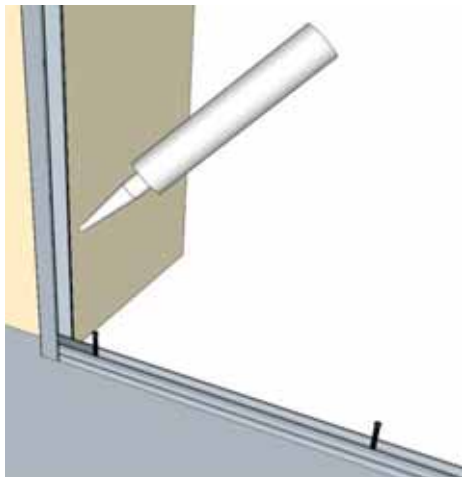

8

Post closing fixing

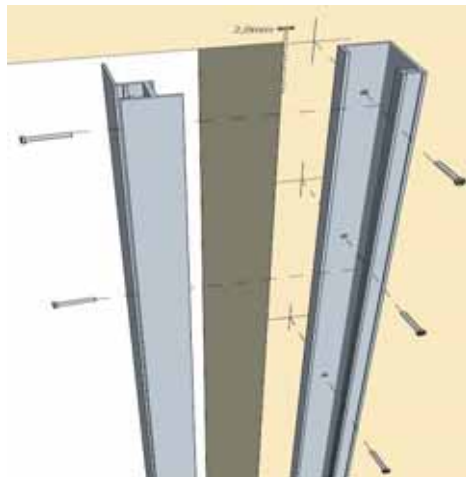

Section

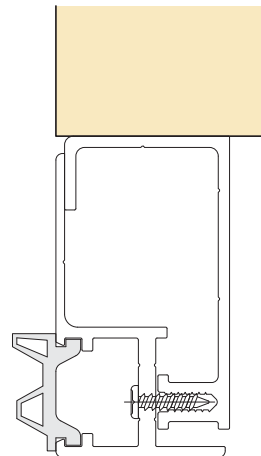

9

Fix wing positioning

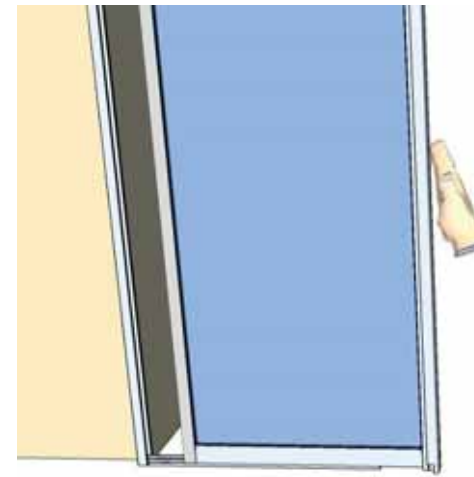

10

Support beam fixing



11

End cap

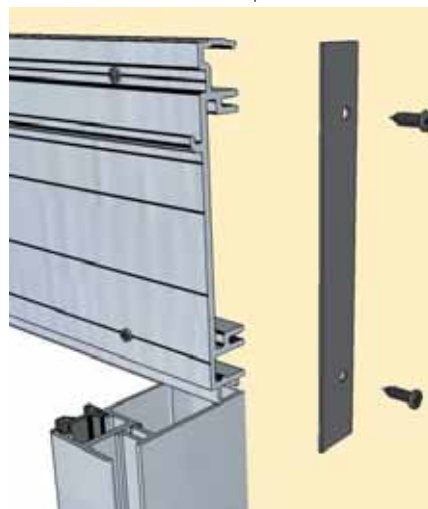

12

Automation climbing

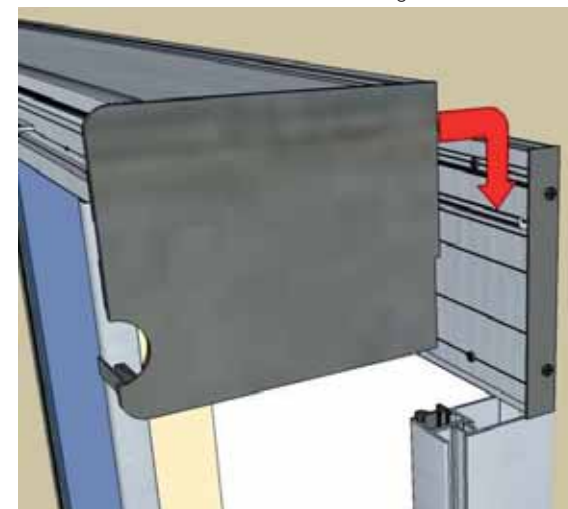

13

Fixing frame installation

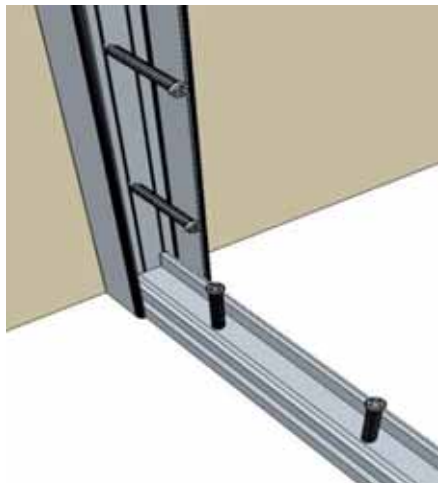

14

Post closing fixing

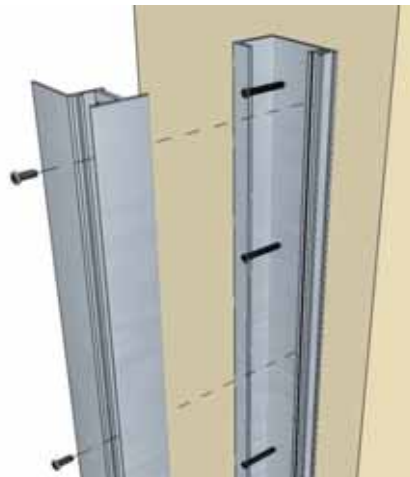

Section

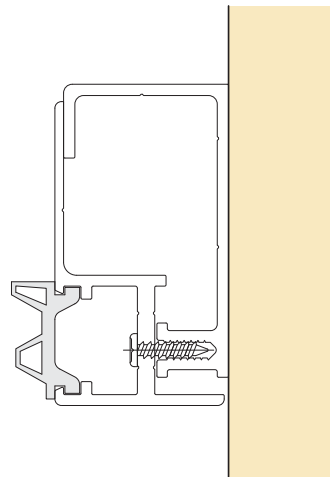

15

Fix wing positioning



16

Floor guide fixing

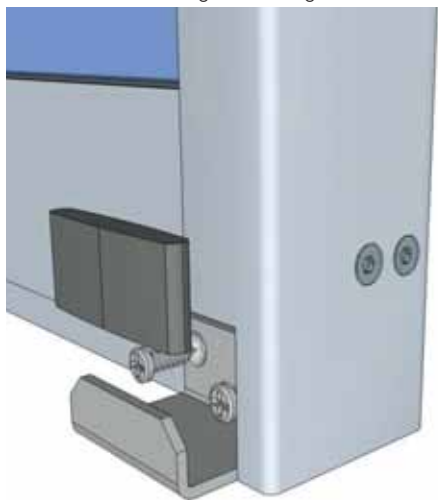

17

Beam holder positioning

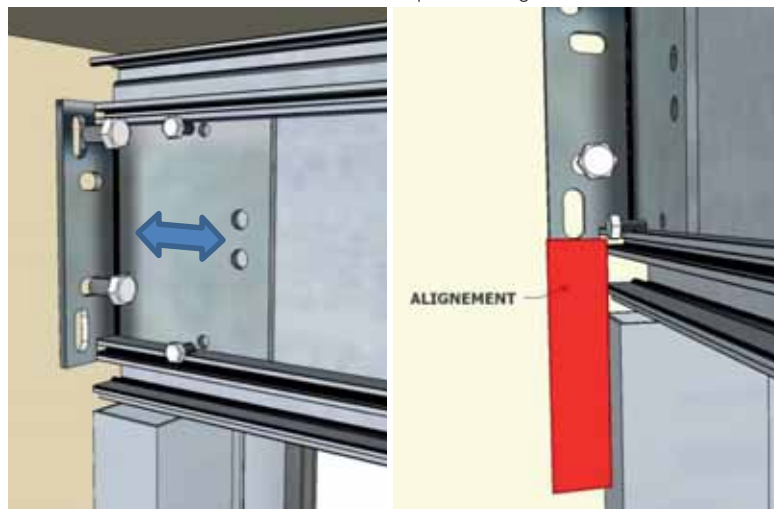

18

Wing lateral side fixing



19

Automation climbing

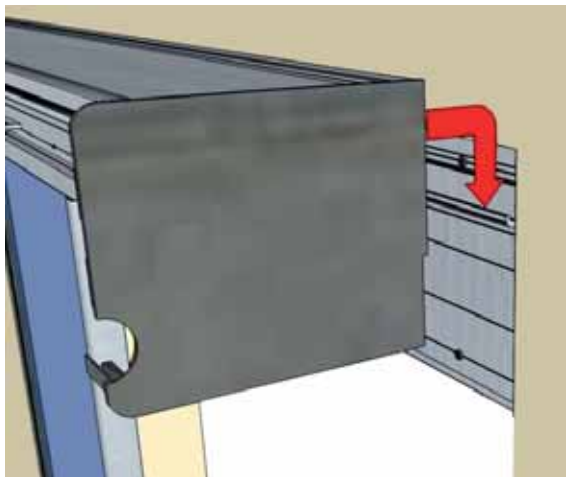

20

Operator fixing

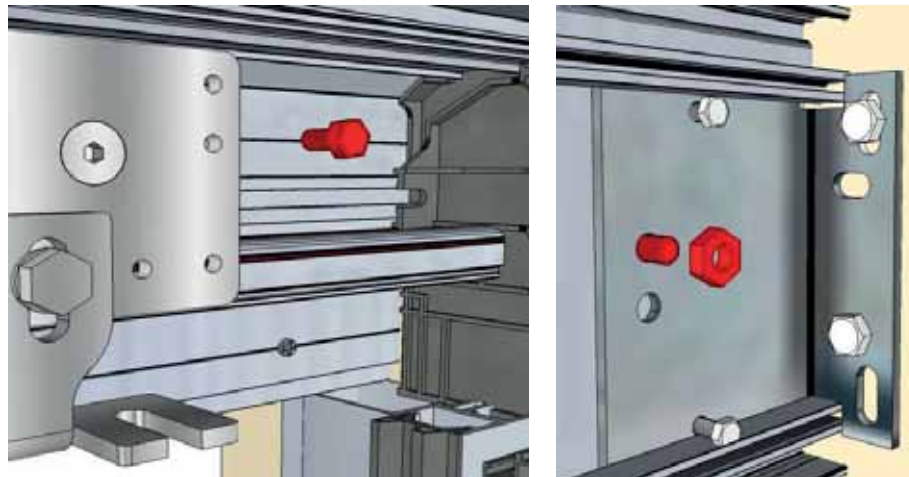

21

Beam cover

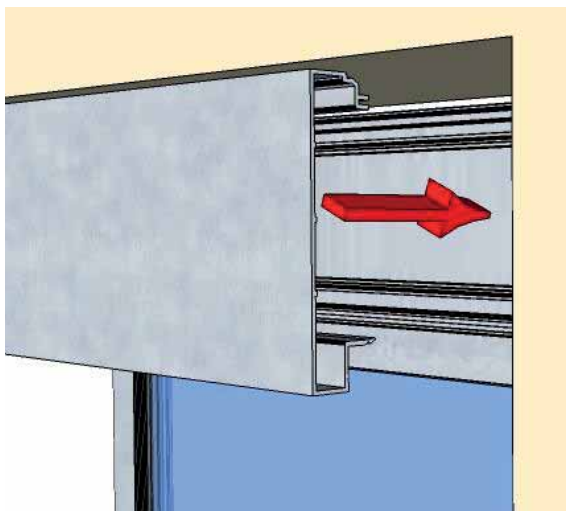

22

Beam cover fixing

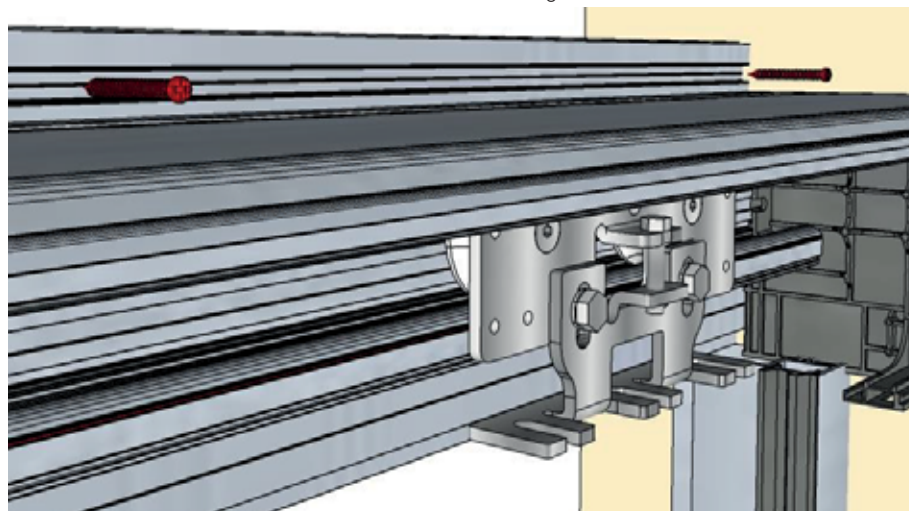

23

Mobile wing bracket fixing

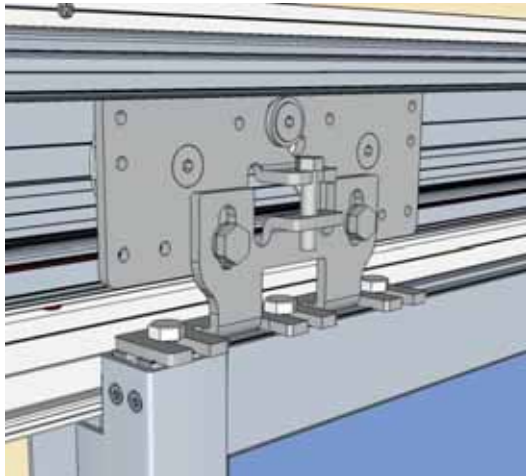

24

Carrier adjustment

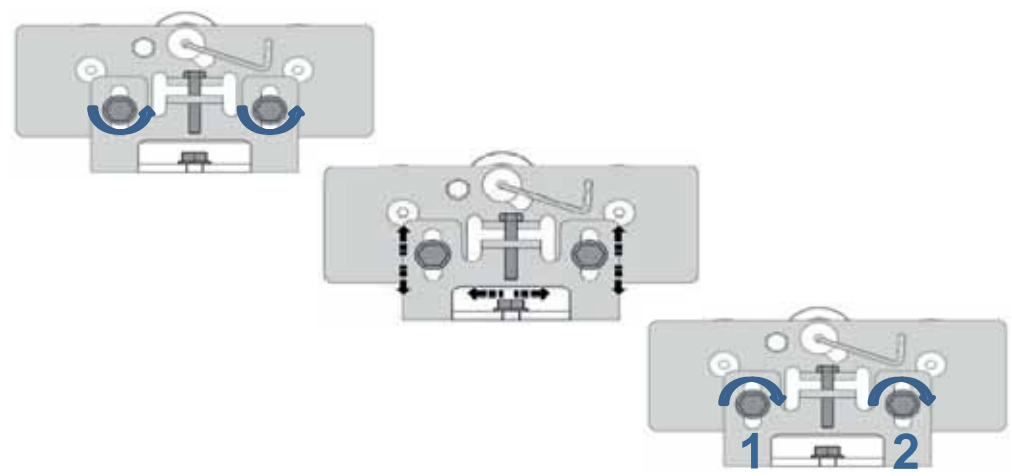

25

Belt adjustment

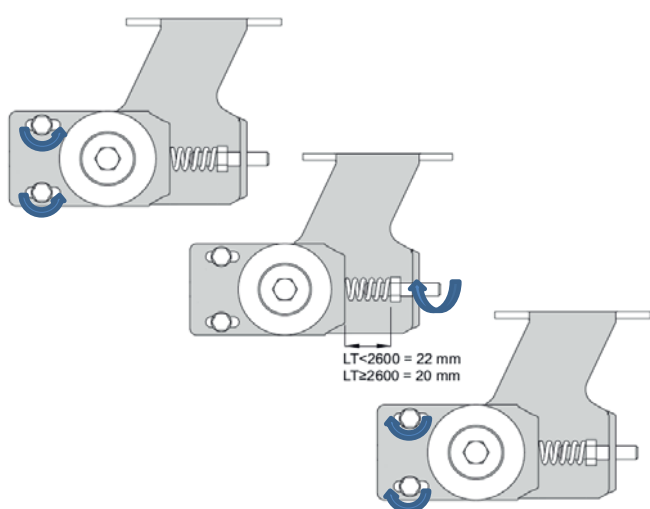

26

Electrolock adjustment

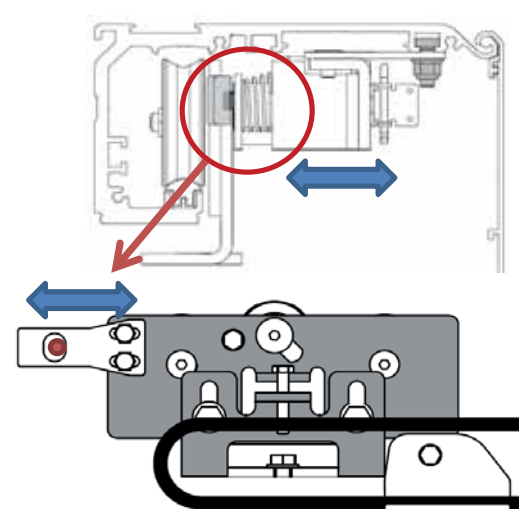

All the rights concerning this material are the exclusive property of Entrematic Group AB.

Although the contents of this publication have been drawn up with the greatest care, Entrematic Group AB cannot be held responsible in any way for any damage caused by mistakes or omissions in this publication. We reserve the right to make changes without prior notice. Copying, scanning and changing in any way are expressly forbidden unless authorised in writing by Entrematic Group AB

Tutti i diritti relativi a questo materiale sono di proprietà esclusiva di Entrematic Group AB.

Sebbene i contenuti di questa pubblicazione siano stati redatti con la massima cura, Entrematic Group AB non può assumersi alcuna responsabilità per danni causati da eventuali errori o omissioni in questa pubblicazione. Ci riserviamo il diritto di apportare eventuali modifiche senza preavviso. Copie, scansioni, ritocchi o modifiche sono espressamente vietate senza un preventivo consenso scritto di Entrematic Group AB.

Alle Rechte an diesem Material sind ausschließliches Eigentum von Entrematic Group AB.

Obwohl der Inhalt dieser Publikation mit größter Sorgfalt erstellt wurde, kann Entrematic Group AB keinerlei Haftung für Schäden übernehmen, die durch mögliche Fehler oder Auslassungen in dieser Publikation verursacht wurden. Wir behalten uns das Recht vor, bei Bedarf Änderungen ohne jegliche Vorankündigung vorzunehmen. Kopien, Scannen, Überarbeitungen oder Änderungen sind ohne vorherige schriftliche Zustimmung von Entrematic Group AB nicht erlaubt.

Tous les droits relatifs à ce matériel sont la propriété exclusive d'Entrematic Group AB.

Bien que les contenus de cette publication aient été rédigés avec le plus grand soin, Entrematic Group AB ne saurait être tenue responsable en cas de dommages dérivant d'erreurs ou d'omissions éventuelles. Nous nous réservons le droit d'apporter des modifications éventuelles sans préavis. Toute copie, reproduction, retouche ou modification est expressément interdite sans l'accord écrit préalable d'Entrematic Group AB.

Todos los derechos relativos a este material son propiedad exclusiva de Entrematic Group AB.

Aunque los contenidos de esta publicación se hayan redactado con la máxima atención, Entrematic Group AB no puede asumir ninguna responsabilidad por daños causados por eventuales errores u omisiones en esta publicación. Nos reservamos el derecho de aportar eventuales modificaciones sin previo aviso. Las copias, los escaneos, los retoques o las modificaciones están expresamente prohibidos sin el consentimiento previo por escrito de Entrematic Group AB.

Todos os direitos relativos a este material são de propriedade exclusiva da Entrematic Group AB.

Embora os conteúdos dessa publicação foram compilados com o maior cuidado, Entrematic Group AB não pode assumir qualquer responsabilidade por danos causados por eventuais erros ou omissões nessa publicação. Reservamo-nos o direito de fazer alterações sem aviso prévio. Cópias, digitalizações, alterações ou modificações são expressamente proibidas sem o consentimento prévio por escrito da Entrematic Group AB.

ENTRE//MATIC

Entrematic Group AB
Lodjursgatan 10
SE-261 44, Landskrona
Sweden
www.entrematic.com

